

AD 2 AERODROMES

ROMY AD 2.1 AERODROME LOCATION INDICATOR AND NAME

ROMY - MIYAKO

ROMY AD 2.2 AERODROME GEOGRAPHICAL AND ADMINISTRATIVE DATA

1	ARP coordinates and site at AD	244658N 1251742E 038°1.0km from RWY 04 THR
2	Direction and distance from (city)	
3	Elevation/ Reference temperature	140ft / 32°C (2004-2008)
4	Geoid undulation at AD ELEV PSN	94ft
5	MAG VAR/ Annual change	4° W(2009)/3.8°W
6	AD Administration, address, telephone, telefax, telex, AFS, e-mail and/or Web-site addresses	Okinawa Pref. Public AP. 1657-128 Aza-Shimozato, Hirara, Miyakojima-city, Okinawa Tel 0980-72-4127 Fax 0980-72-1958
7	Types of traffic permitted(IFR/ VFR)	IFR/VFR
8	Remarks	Nil

ROMY AD 2.3 OPERATIONAL HOURS

1	AD Administration	2300 - 1200
2	Customs and immigration	On request Customs: 0980-72-2310 Immigration: 0980-72-3440
3	Health and sanitation	Quarantine(human): On request(0980-73-5115) Quarantine(animal, plant): Nil
4	AIS Briefing Office	Nil
5	ATS Reporting Office(ARO)	Nil
6	MET Briefing Office	H24 (NAHA)
7	ATS	2300 - 1200
8	Fuelling	On request
9	Handling	Ask AD administration
10	Security	Ask AD administration
11	De-icing	Nil
12	Remarks	Nil

ROMY AD 2.4 HANDLING SERVICES AND FACILITIES

1	Cargo-handling facilities	Conveyer belt, Lift for loading etc
2	Fuel/ oil types	JET A-1
3	Fuelling facilities/ capacity	Tanker truck-refueling system
4	De-icing facilities	Nil
5	Hangar space for visiting aircraft	Nil
6	Repair facilities for visiting aircraft	Nil
7	Remarks	Nil

ROMY AD 2.5 PASSENGER FACILITIES

1	Hotels	Hotels in Miyakojima city
2	Restaurants	At airport In Miyakojima city
3	Transportation	Buses and Taxi
4	Medical facilities	Hospital 2.5km from airport
5	Bank and Post Office	At airport Bank in Miyakojima city / Post Office in Miyakojima city
6	Tourist Office	At airport In Miyakojima city
7	Remarks	Nil

ROMY AD 2.6 RESCUE AND FIRE FIGHTING SERVICES

1	AD category for fire fighting	Fire protection ; Scale of protection ICAO required : CAT 8 Available : CAT 8
2	Rescue equipment	Chemical fire fighting truck x 3
3	Capability for removal of disabled aircraft	Incapable
4	Remarks	Nil

ROMY AD 2.7 SEASONAL AVAILABILITY-CLEARING

1	Types of clearing equipment	Not Applicable
2	Clearance priorities	Not Applicable
3	Remarks	Nil

ROMY AD 2.8 APRONS, TAXIWAYS AND CHECK LOCATIONS DATA

1	Apron surface and strength	Surface : Cement-concrete Strength : PCN 55/R/B/X/T
2	Taxiway width, surface and strength	Width : 30m Surface : Asphalt-concrete Strength : T1:PCN 58/F/C/X/T, T2:PCN 74/F/D/X/T
3	ACL and elevation	Not available
4	VOR checkpoints	Not available
5	INS checkpoints	Spot NR 1: 244650.84N 1251752.38E 2: 244649.82N 1251750.13E 3 : 244648.45N 1251750.11E 5 : 244647.05N 1251748.81E 6 : 244645.70N 1251747.44E
6	Remarks	Nil

ROMY AD 2.9 SURFACE MOVEMENT GUIDANCE AND CONTROL SYSTEM AND MARKINGS

1	Use of aircraft stand ID signs, TWY guide lines and Visual docking/ parking guidance system of aircraft stands	Nil
2	RWY and TWY markings and LGT	RWY:04/22 (Marking) RWY designation, RWY CL, RWY THR, Aiming point, TDZ, RWY side stripe, RWY turn pad edge, RWY turn pad CL, RWY middle point (LGT) RCLL, REDL, RTHL, RENL, WBAR, Turning point indicator LGT TWY: (Marking)TWY CL, TWY side stripe (LGT) TWY edge LGT, TWY CL LGT, Taxiing guidance sign
3	Stop bars	Nil
4	Remarks	(Marking) Overrun area (LGT) Apron flood LGT

B-767型機用の滑走路180° 旋回用標識(灯火)及び実施要項

付図に示す転回灯1が一直線に見えるように進行し、転回灯2が一直線に見えた時転回を開始する。

転回時はMAX STEERING ANGLEを使用する。

Marking(Lights)for 180° turn on runway of B-767 aircraft and Procedure using the Marking

Proceed along the RWY Turn Pad Center Line Marking to see the Turning Point Indicator Light 1 on a straight line, then commence turn at the spot where you (pilot) can see the Turning Point Indicator Light 2 on a straight line at an angle of 9 o'clock. When turning, take MAX STEERING ANGLE.

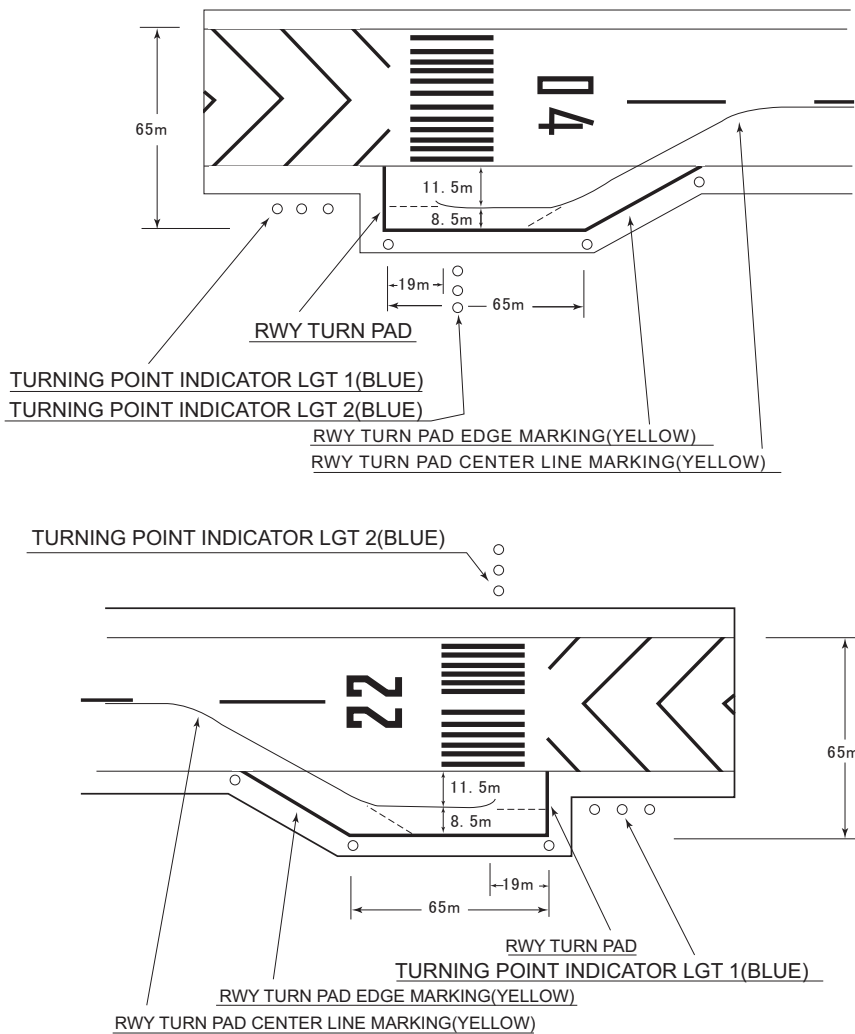

ROMY AD 2.10 AERODROME OBSTACLES

In approach/TKOF areas

RWY/Area affected	Obstacle type	Coordinates	Elevation	Markings/LGT	Remarks
RWY22	Concrete tank	244739.0N/1251816.0E	183ft	- / LIL	under approach surface
RWY22	Concrete tank	244740.0N/1251815.0E	182ft	- / -	under approach surface

In circling area and at AD

Obstacle type	Coordinates	Elevation	Markings/LGT	Remarks
Building	244732.5N/1251801.6E	179ft	- / LIL	under transitional surface
Tower	244815.1N/1251758.2E	390ft	Marking / LIL	above horizontal surface
Building	244649.0N/1251726.1E	147ft	- / LIL	under transitional surface

ROMY AD 2.11 METEOROLOGICAL INFORMATION PROVIDED

1	Associated MET Office	NAHA
2	Hours of service MET Office outside hours	H24 (NAHA)
3	Office responsible for TAF preparation Periods of validity	Nil
4	Trend forecast Interval of issuance	Nil
5	Briefing/ consultation provided	Briefing is available upon inquiry at NAHA
6	Flight documentation Language(s) used	C En
7	Charts and other information available for briefing or consultation	S ₆ , U ₈₅ , U ₇ , U ₅ , U ₃ , U ₂₅ , U ₂ /T _r , P _S , P ₅ , P ₃ , P ₂₅ , P _{SWE} , P _{SWF} , P _{SWG} , P _{SWI} , P _{SWM} , P _{SW} (domestic), E, C, W _E , W _F , W _G , W _I , W, N
8	Supplementary equipment available for providing information	Nil
9	ATS units provided with information	TWR
10	Additional information(limitation of service, etc.)	Nil

ROMY AD 2.12 RUNWAY PHYSICAL CHARACTERISTICS

Designations RWY NR	TRUE BRG	Dimensions of RWY(M)	Strength(PCN) and surface of RWY	THR coordinates THR geoid undulation	THR elevation and highest elevation of TDZ of precision APP RWY
1	2	3	4	5	6
04	038.31°	2000×45	PCN 56/F/B/X/T Asphalt-concrete	244632.65N 1251720.41E 93.5ft	THR ELEV: 124ft
22	218.31°	2000×45	PCN 56/F/B/X/T Asphalt-concrete	244723.66N 1251804.56E 93.7ft	THR ELEV: 149.9ft TDZ ELEV: 149.9ft
Slope of RWY	Strip Dimensions(M)	RESA (Overrun) Dimensions (M)	Remarks		
7	10	11	14		
See AD2.24 AD chart	2120×300 2120×300	43×305	RWY Grooving:2000m×30m 192×(MNM:140 MAX:284)* *For detail, ask airport administrator		

ROMY AD 2.13 DECLARED DISTANCES

RWY Designator	TORA (m)	TODA (m)	ASDA (m)	LDA (m)	Remarks
1	2	3	4	5	6
04	2000	2000	2000	2000	Nil
22	2000	2000	2000	2000	Nil

ROMY AD 2.14 APPROACH AND RUNWAY LIGHTING

RWY Designator	APCH LGT type LEN INTST	RTHL Color WBAR	PAPI (VASIS) Angle DIST FM THR MEHT	RTZL LEN	RCLL LEN Spacing Color INTST	REDL LEN Spacing Color INTST	RENL Color WBAR	STWL LEN Color
1	2	3	4	5	6	7	8	9
04	SALS (*1) 420m LIH	Green Green	PAPI 3.0°/Left 373.4m 61ft	-	2000m 30m Coded color (White/Red) LIH	2000m 60m Coded color (White/Yellow) LIH	Red	Nil (*2)
22	PALS (CAT I) 900m LIH	Green Green	PAPI 3.0° /Left 385.8m 61ft	900m	2000m 30m Coded color (White/Red) LIH	2000m 60m Coded color (White/Yellow) LIH	Red	Nil (*2)
Remarks								
10								
SALS with APCH LGT beacon (600m and 900m FM RWY THR) (*1) Overrun area edge LGT(LEN:60m color:Red) (*2)								

ROMY AD 2.15 OTHER LIGHTING, SECONDARY POWER SUPPLY

1	ABN/IBN location, characteristics and hours of operation	ABN: 244648N/1251757E, White/Green EV4.3sec, HO
2	LDI location and LGT Anemometer location and LGT	LDI: Nil Anemometer : RWY 04 : 45m from RWY 04 THR, lighted RWY 22 : 150m from RWY 22 THR, lighted
3	TWY edge and center line lighting	TWY edge and center line lights installed, see AD2.9
4	Secondary power supply/ switch-over time	Within 1 sec: REDL, RENL, RTHL, WBAR, RCLL, Turning point indicator LGT and Overrun area edge LGT Within 15 sec: other LGT
5	Remarks	WDI LGT

ROMY AD 2.16 HELICOPTER LANDING AREA

Nil

ROMY AD 2.17 ATS AIRSPACE

Designation and lateral limits		Vertical limits (ft)	Airspace classification	ATS unit call sign Language	Remarks
1		2	3	4	6
Miyako CTR	Area within a radius of 5nm of MIYAKO ARP	3,000 or below	D	Miyako TWR En	
Sakishima ACA	See attached chart		E	Sakishima APP Sakishima DEP Sakishima RADAR En	

先島進入管制区
Sakishima Approach Control Area

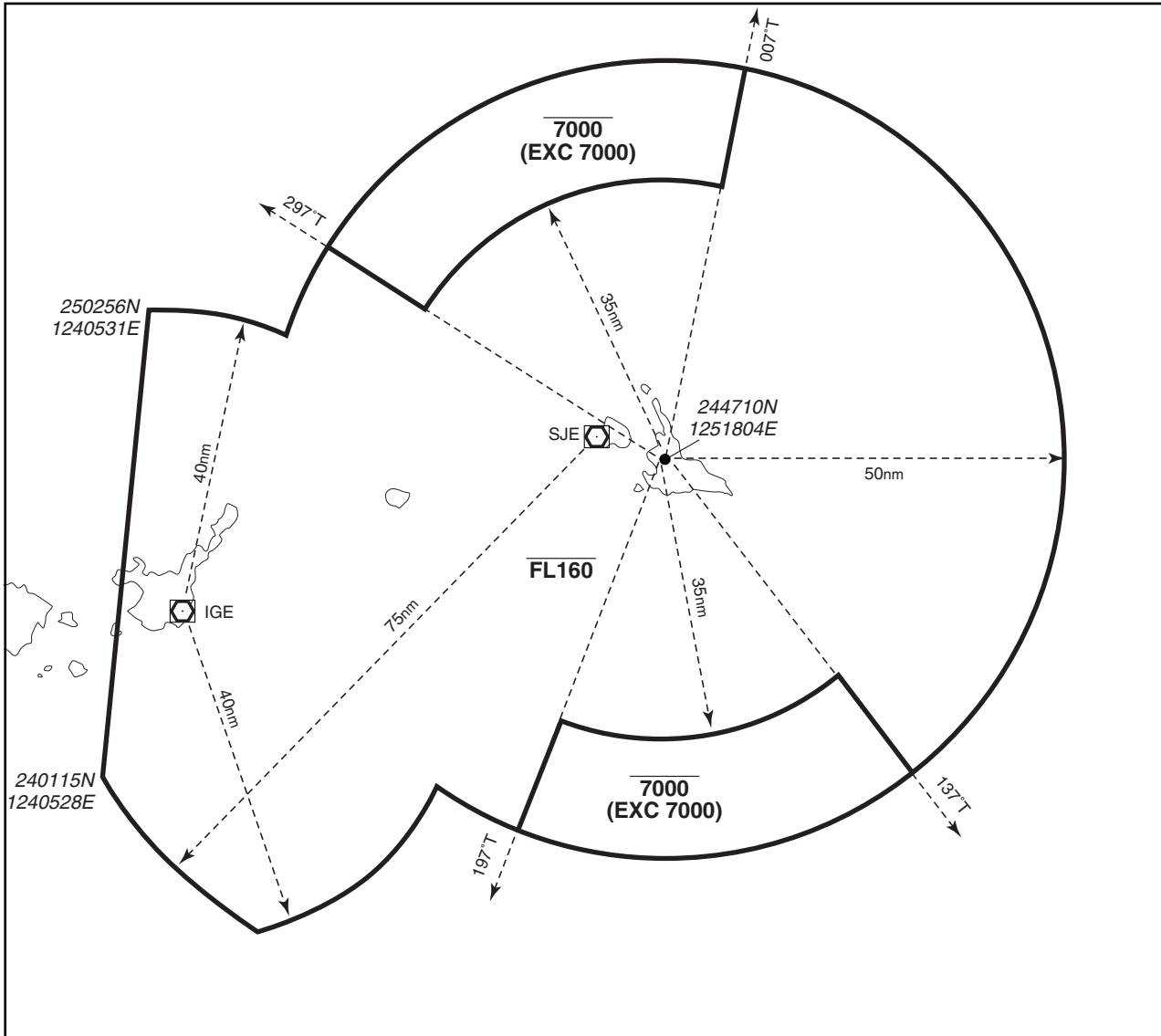

ROMY AD 2.18 ATS COMMUNICATION FACILITIES

Service designation	Call sign	Frequency	Hours of operation	Remarks
1	2	3	4	5
TWR	Miyako Tower	118.2MHz(1) 126.2MHz	2300 - 1200 (1)Primary	
APP/ASR	Sakishima Approach/ Sakishima Radar	125.0MHz(1) 121.2MHz 120.3MHz 121.5MHz(E) 243.0MHz(E)	2300 - 1200	APP service provided by Sakishima APP
DEP	Sakishima Departure	125.0MHz 121.5MHz(E) 243.0MHz(E)	2300 - 1200	

ROMY AD 2.19 RADIO NAVIGATION AND LANDING AIDS

Type of aid (VOR declination)	ID	Frequency	Hours of operation	Position of transmitting antenna coordinates	Elevation of DME transmitting antenna	Remarks
1	2	3	4	5	6	7
VOR (4°W/2013)	MJC	113.45MHz	H24	244638.61N/ 1251736.27E		
TACAN	MJC	1042MHz (CH-81Y)	H24	244637.24N/ 1251735.33E	152ft	TACAN AZM unusable: 050° - 060° beyond 20nm BLW 3000ft. 060° - 090° beyond 30nm BLW 3000ft. 090° - 110° beyond 25nm BLW 3000ft. 110° - 130° beyond 30nm BLW 3000ft. 130° - 160° beyond 35nm BLW 3000ft.
ILS-LOC 22	IMY	108.9MHz	2300 - 1200	244626.65N/ 1251715.21E		LOC: 235m(771ft) away FM RWY 04 THR, BRG(MAG) 223°
ILS-GP 22	-	329.3MHz	2300 - 1200	244713.24N/ 1251800.99E		GP: 315m(1033ft) inside FM RWY 22 THR. 120m(394ft) SE of RCL Angle 3.0°, HGT of ILS Ref datum 16.5m(54ft)
ILS-DME 22	IMY	987MHz	2300 - 1200	244712.74N/ 1251801.01E	163ft	DME: 325m(1066ft) inside FM RWY 22 THR. 130m(427ft) SE of RCL.
MSAS		1575.42MHz	H24			Transmitting antennas are satellite based

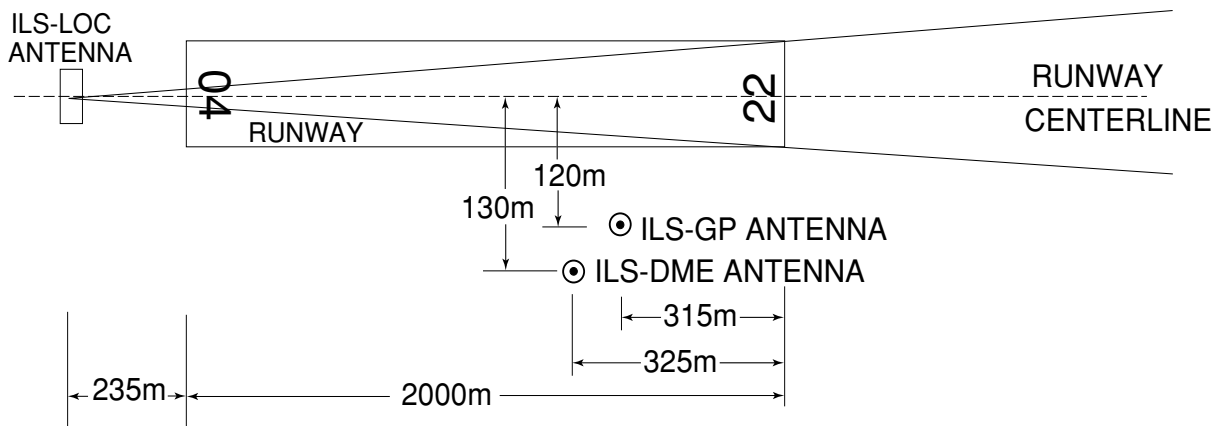

REMARKS : 1. ILS-LOC beam BRG(MAG) 223°
2. HGT of ILS REF datum 16.5m(54ft)
3. ILS-GP Angle 3.0°

ROMY AD 2.20 LOCAL TRAFFIC REGULATIONS

1. Airport regulations

Nil

2. Taxiing to and from stands

Nil

3. Parking area for small aircraft(General aviation)

Nil

4. Parking area for helicopters

Nil

5. Apron - taxiing during winter conditions

Nil

6. Taxiing - limitations

Nil

7. School and training flights - technical test flights - use of runways

Nil

8. Helicopter traffic - limitation

Nil

9. Removal of disabled aircraft from runways

Nil

ROMY AD 2.21 NOISE ABATEMENT PROCEDURES

Nil

ROMY AD 2.22 FLIGHT PROCEDURES

1. Lost communication procedures for arrival aircraft under radar navigational guidance
 If radio communications with Sakishima Approach/Radar are lost for one minute, squawk Mode A/3 Code 7600 and:
 1) Contact Miyako Tower.
 2) If unable, proceed in accordance with visual flight rules.
 3) If unable, proceed to Miyakojima VORTAC at the last assigned altitude, or 3,000 feet whichever is higher, and execute instrument approach.
 Note: Procedures other than above will be issued when situation requires.

2. TAKE OFF MINIMA

	RWY	ACFT CAT	REDL & RCLL		REDL or RCLL or RCL Marking		NIL (DAYTIME ONLY)	
			RVR	VIS	RVR	VIS	RVR	VIS
Multi-Engine ACFT with TKOF ALTN AP FILED	04	A,B,C,D	-	400m	-	400m	-	500m
	22	A,B,C,D	400m	400m	400m	400m	-	500m
OTHER	04	A,B,C,D	AVBL LDG MINIMA					
	22	A,B,C,D						

3. Terminal Radar Alphanumeric Display System (TRAD)

先島アプローチの指示のもとに、当該進入管制区を飛行する航空機は、モード A/3 の二次レーダー個別コード及びモード C による応答を指示される。

Aircraft flying under control of Sakishima approach control in the approach control area will be instructed to reply with discrete code on Mode A/3 and Mode C.

二次レーダー個別コードを搭載していない航空機が当該コードによる応答を指示された場合は、管制官に対しその旨通報すること。

If an aircraft with non-discrete code capability be instructed to reply with the discrete code, it shall report a controller accordingly.

ROMY AD 2.23 ADDITIONAL INFORMATION

Nil

ROMY AD 2.24 CHARTS RELATED TO AN AERODROME

Aerodrome/Heliport Chart
Standard Departure Chart - Instrument (TORII-RNAV, UMAKI-RNAV)
Standard Departure Chart - Instrument (NAHA, WEST)
Standard Arrival Chart - Instrument (COOBA EAST-RNAV)
Standard Arrival Chart - Instrument (YUTAH WEST-RNAV)
Standard Arrival Chart - Instrument (COOBA NORTH-RNAV)
Standard Arrival Chart - Instrument (YUTAH NORTH-RNAV)
Instrument Approach Chart (ILS Z or LOC Z RWY 22)
Instrument Approach Chart (ILS Y or LOC Y RWY 22)
Instrument Approach Chart (VOR RWY 04)
Instrument Approach Chart (VOR RWY 22)
Instrument Approach Chart (RNAV (GNSS) Z RWY 04)
Instrument Approach Chart (RNAV (RNP) Y RWY 04)
Instrument Approach Chart (RNAV (RNP) X RWY 04)
Other Chart (Visual REP)
Other Chart (MVA CHART)

ROMY / MIYAKO

AD CHART

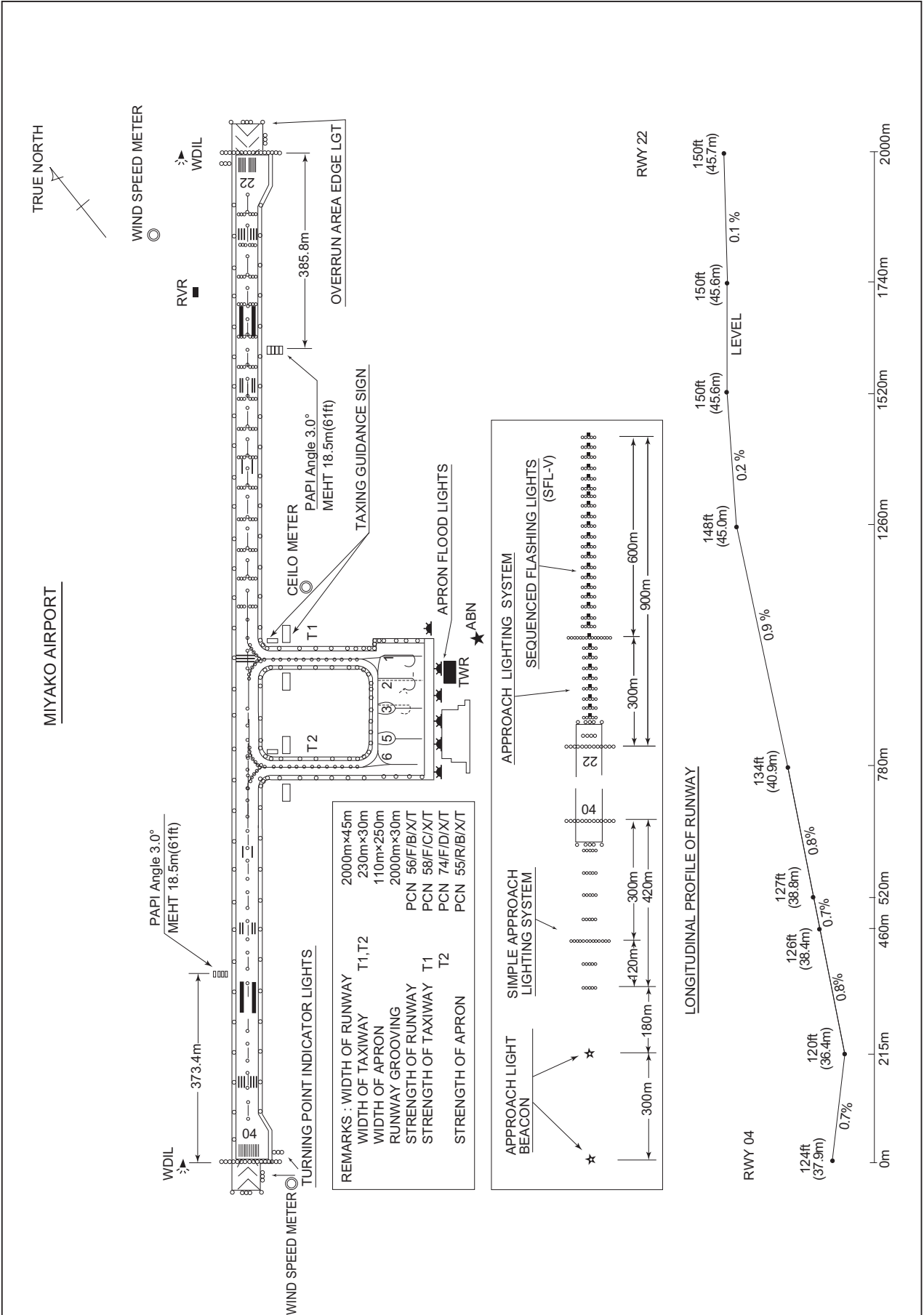

INTENTIONALLY LEFT BLANK

INSTRUMENT APPROACH CHART

ROMY / MIYAKO

VOR RWY22

SAKISHIMA APP 125.0 -121.2	MIYAKOJIMA VORTAC 113.45 MJC CH-81Y ㊦㊧㊨ 24°46'39"N/125°17'36"E	MIYAKO TOWER 118.2 -126.2	RADAR AVBL
-------------------------------	---	------------------------------	------------

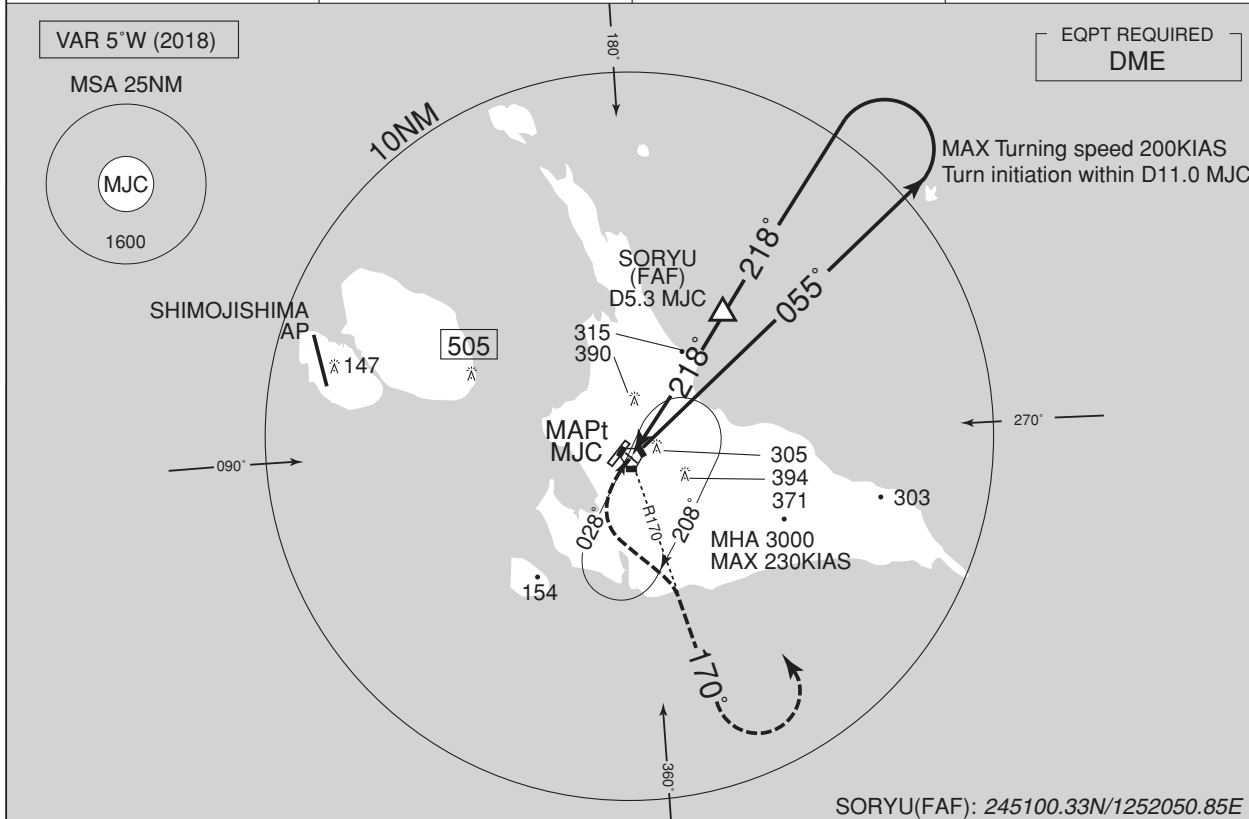

NM to MJC	MAPt	3	4	5	FAF
ALT (3.0° APCH Path)	-	881	1200	1518	1600

MISSED APPROACH

Turn left, climb via MJC R170 to 2000FT, turn left, direct to MJC VORTAC and hold at 3000FT. Contact SAKISHIMA APP.

Timing not authorized for defining the MAPt.

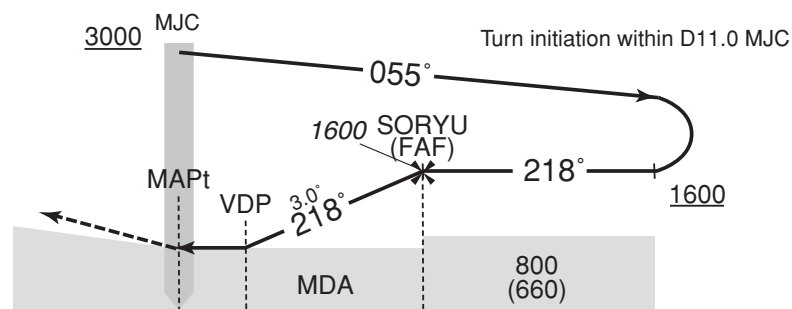

DME to MJC	0.9	2.3	5.3
NM to THR	0	1.5	4.4

MINIMA		THR elev. 150	AD elev. 140
CAT	CIRCLING		
	MDA(H)	RVR/CMV	MDA(H) VIS
A	640 (500)	1000	710 (570)
B		1200	
C			1600
D			

STANDARD ARRIVAL CHART - INSTRUMENT

ROMY / MIYAKO

RNAV STAR RWY04

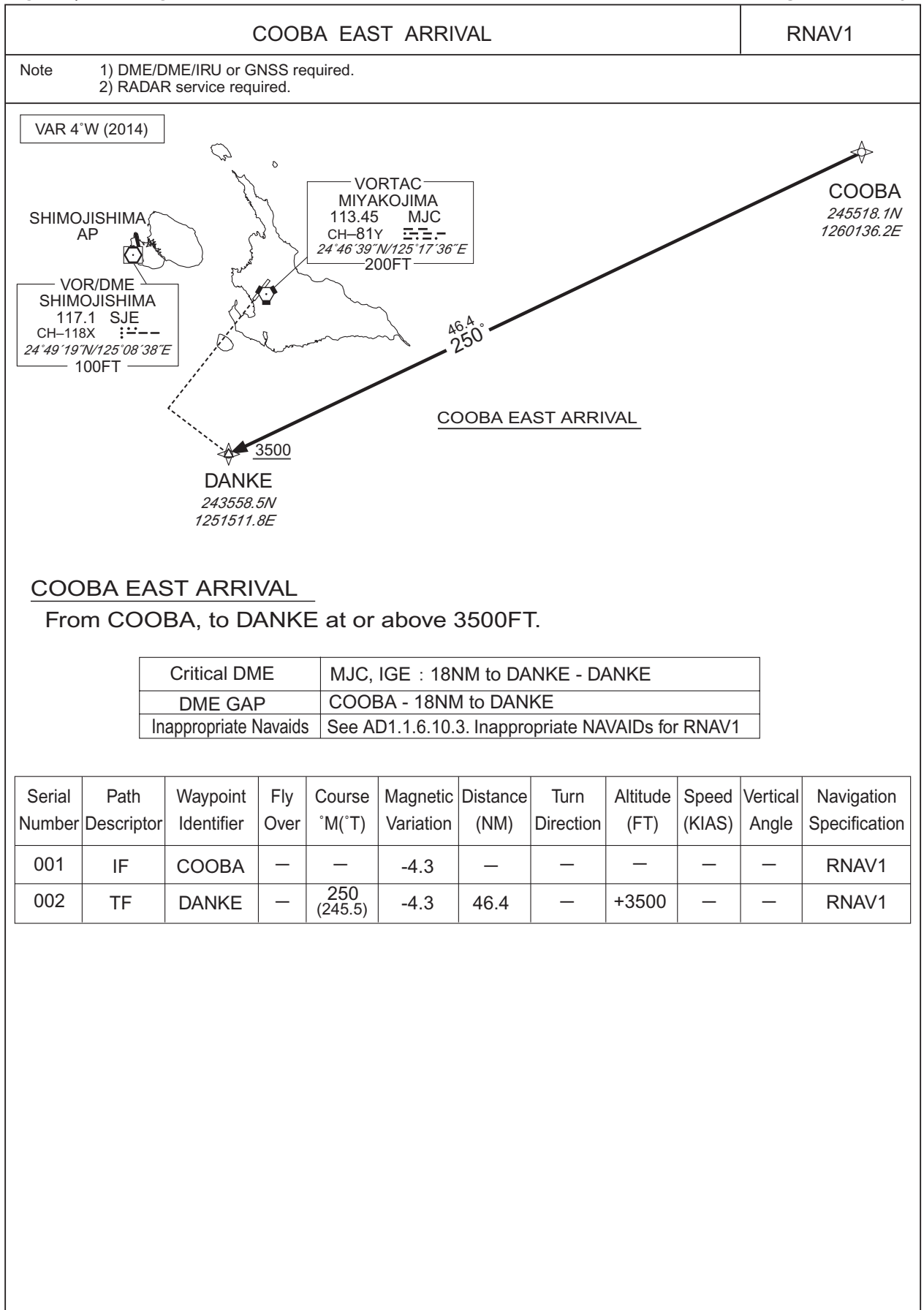

ROMY / MIYAKO

Visual REP

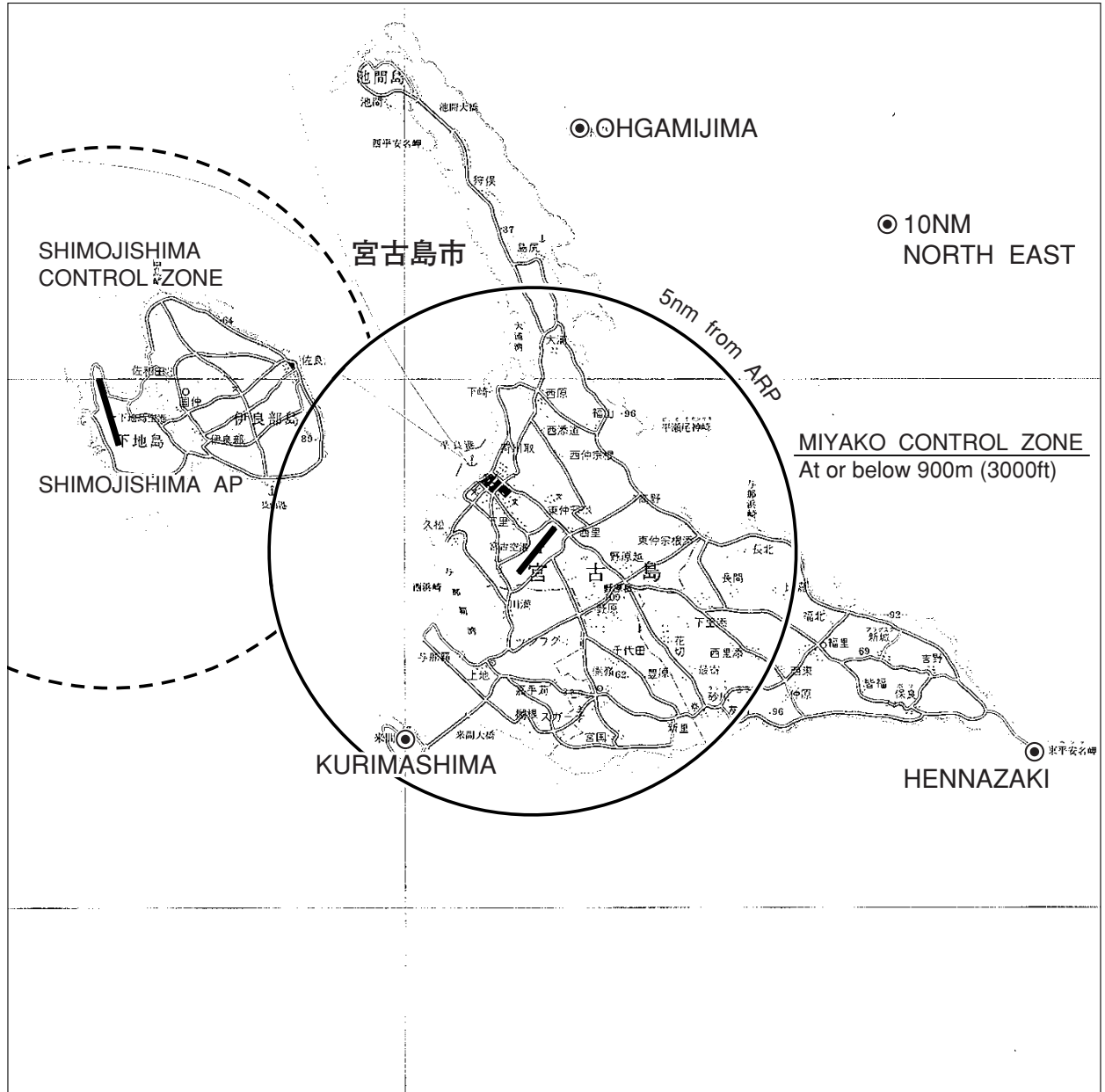

Call sign	BRG / DIST from ARP	Remarks
10NM NORTH EAST	045°/10.0NM	海上 Over the sea
大神島 Ohgamijima	009°/ 8.0NM	島 Island
来間島 Kurimashima	220°/ 4.5NM	島 Island
平安名崎 Hennazaki	115°/10.0NM	灯台 Lighthouse

INSTRUMENT APPROACH CHART

ROMY / MIYAKO

RNAV(GNSS) Z RWY04

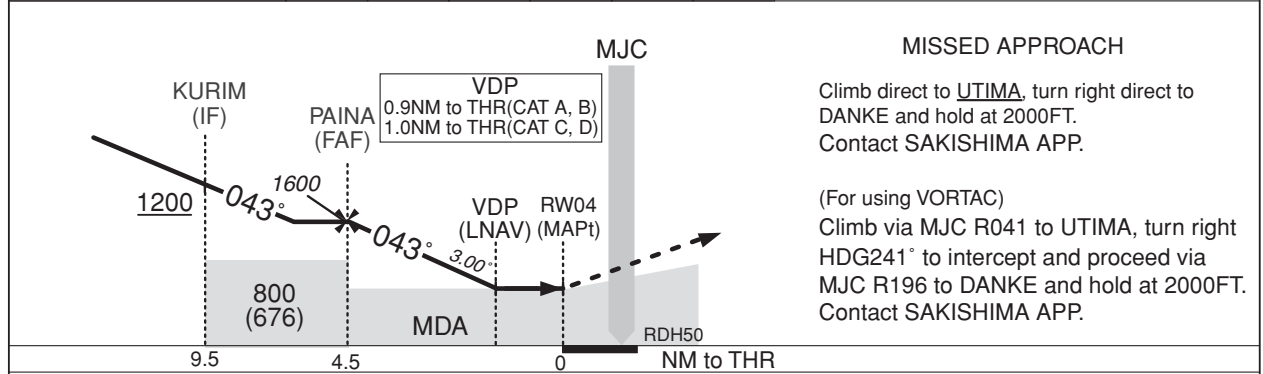
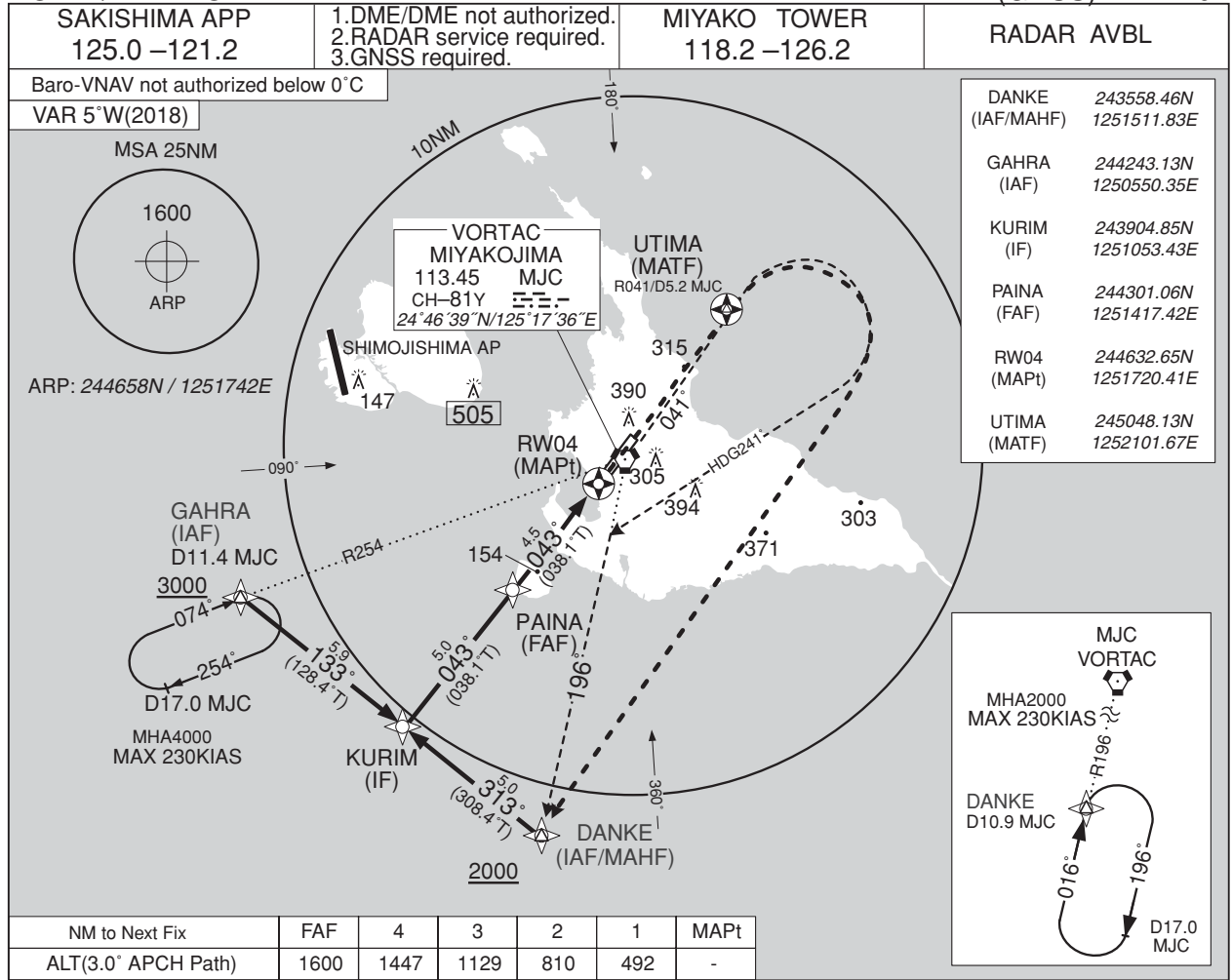

MINIMA		THR elev. 124		AD elev. 140		
CAT	LNAV/VNAV		LNAV		CIRCLING	
	DA(H)	CMV	MDA(H)	CMV	MDA(H)	VIS
A	460(336)	1200	460(336)	1200	710(570)	1600
B		1300		1300		
C	480(356)	1400	480(356)	1400		
D		1600		1600		
						3200

STANDARD ARRIVAL CHART - INSTRUMENT

ROMY / MIYAKO

RNAV STAR RWY04

YUTAH WEST ARRIVAL	RNAV1
--------------------	-------

Note 1) DME/DME/IRU or GNSS required.
2) RADAR service required.

VAR 4°W (2014)

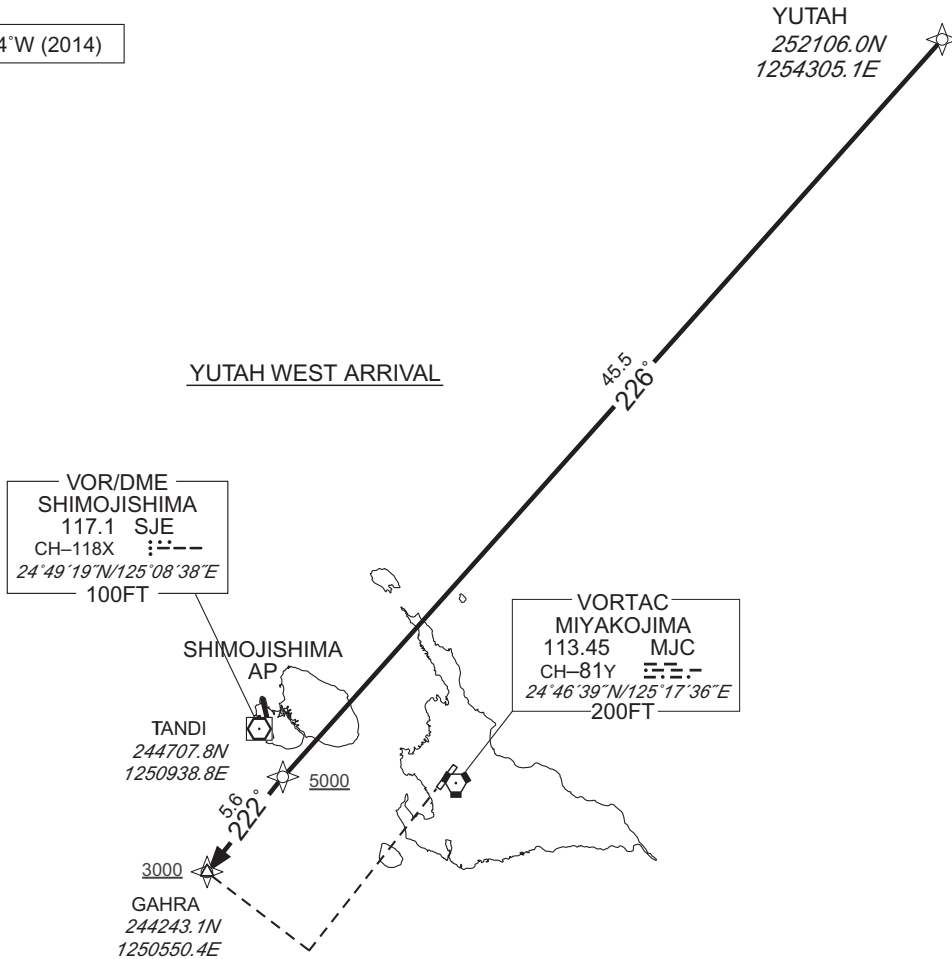

YUTAH WEST ARRIVAL

From YUTAH, to TANDI at or above 5000FT, to GAHRA at or above 3000FT.

Critical DME	MJC, IGE : 8NM to TANDI - TANDI
DME GAP	YUTAH - 8NM to TANDI TANDI - GAHRA
Inappropriate Nav aids	See AD1.1.6.10.3. Inappropriate NAVAIDS for RNAV1

Serial Number	Path Descriptor	Waypoint Identifier	Fly Over	Course °M(°T)	Magnetic Variation	Distance (NM)	Turn Direction	Altitude (FT)	Speed (KIAS)	Vertical Angle	Navigation Specification
001	IF	YUTAH	—	—	-4.3	—	—	—	—	—	RNAV1
002	TF	TANDI	—	226 (221.8)	-4.3	45.5	—	+5000	—	—	RNAV1
003	TF	GAHRA	—	222 (218.1)	-4.3	5.6	—	+3000	—	—	RNAV1

STANDARD ARRIVAL CHART - INSTRUMENT

ROMY / MIYAKO

RNAV STAR RWY22

COOBA NORTH ARRIVAL	RNAV1
---------------------	-------

Note 1) GNSS required.
2) RADAR service required.

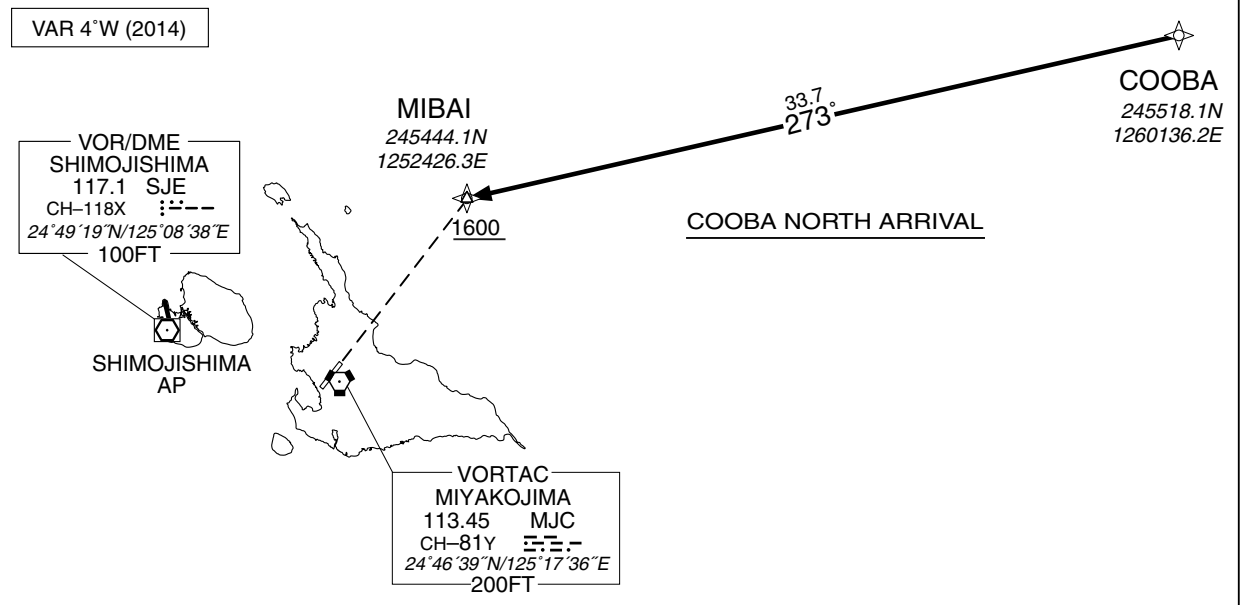

COOBA NORTH ARRIVAL

From COOBA, to MIBAI at or above 1600FT.

Critical DME	-
DME GAP	COOBA - MIBAI
Inappropriate Nav aids	See AD1.1.6.10.3. Inappropriate NAVAIDs for RNAV1

Serial Number	Path Descriptor	Waypoint Identifier	Fly Over	Course °M(°T)	Magnetic Variation	Distance (NM)	Turn Direction	Altitude (FT)	Speed (KIAS)	Vertical Angle	Navigation Specification
001	IF	COOBA	—	—	-4.3	—	—	—	—	—	RNAV1
002	TF	MIBAI	—	273 (269.2)	-4.3	33.7	—	+1600	—	—	RNAV1

STANDARD ARRIVAL CHART - INSTRUMENT

ROMY / MIYAKO

RNAV STAR RWY22

YUTAH NORTH ARRIVAL	RNAV1
---------------------	-------

Note 1) GNSS required.
2) RADAR service required.

VAR 4°W (2014)

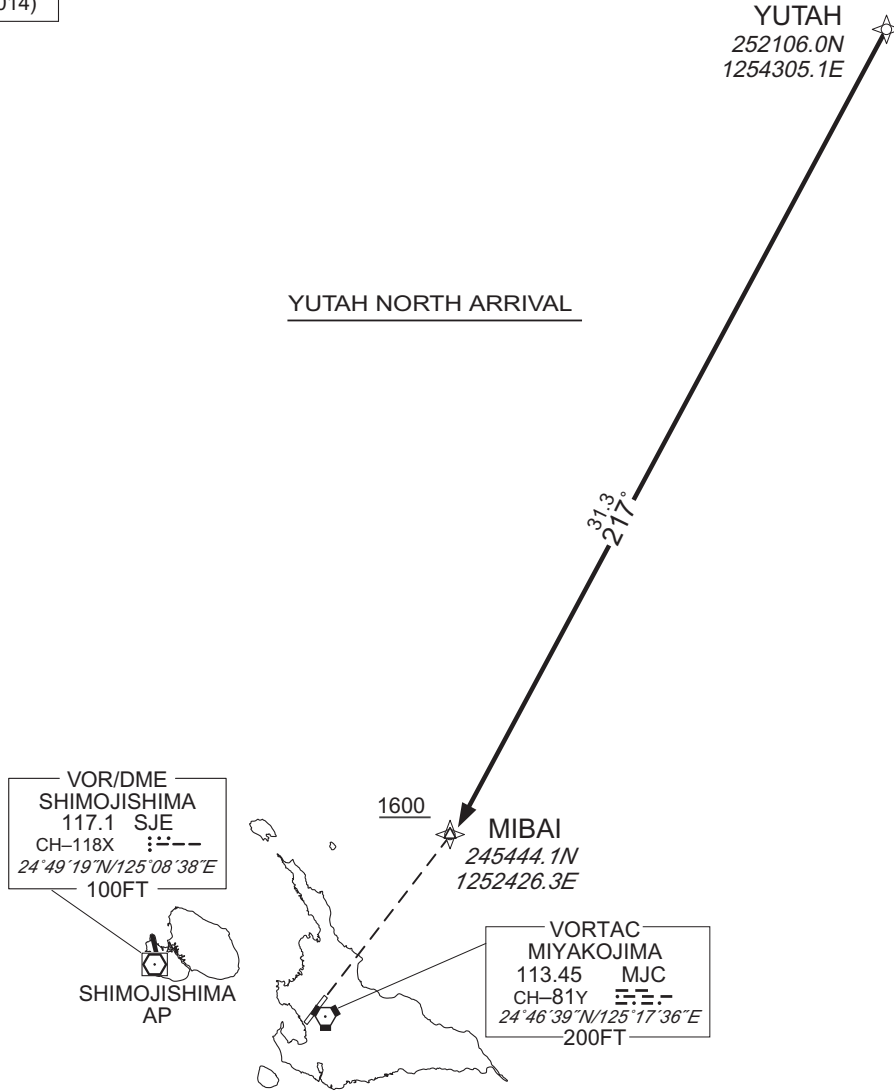

YUTAH NORTH ARRIVAL

From YUTAH, to MIBAI at or above 1600FT.

Critical DME	-
DME GAP	YUTAH - MIBAI
Inappropriate NavAids	See AD1.1.6.10.3. Inappropriate NAVAIDs for RNAV1

Serial Number	Path Descriptor	Waypoint Identifier	Fly Over	Course °M(°T)	Magnetic Variation	Distance (NM)	Turn Direction	Altitude (FT)	Speed (KIAS)	Vertical Angle	Navigation Specification
001	IF	YUTAH	-	-	-4.3	-	-	-	-	-	RNAV1
002	TF	MIBAI	-	217 (212.7)	-4.3	31.3	-	+1600	-	-	RNAV1

CHANGE: ALT restriction added in Coding Table.

INSTRUMENT APPROACH CHART

ROMY / MIYAKO

RNAV(RNP) Y RWY04

SAKISHIMA APP 125.0 -121.2	GNSS and RF required.	MIYAKO TOWER 118.2 -126.2	RADAR AVBL
-------------------------------	-----------------------	------------------------------	------------

For uncompensated Baro-VNAV systems, procedure not authorized below 0°C / above 45°C

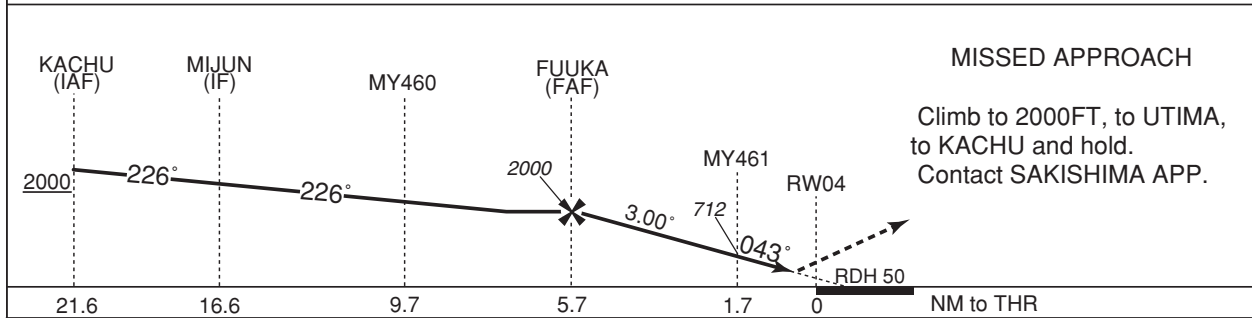
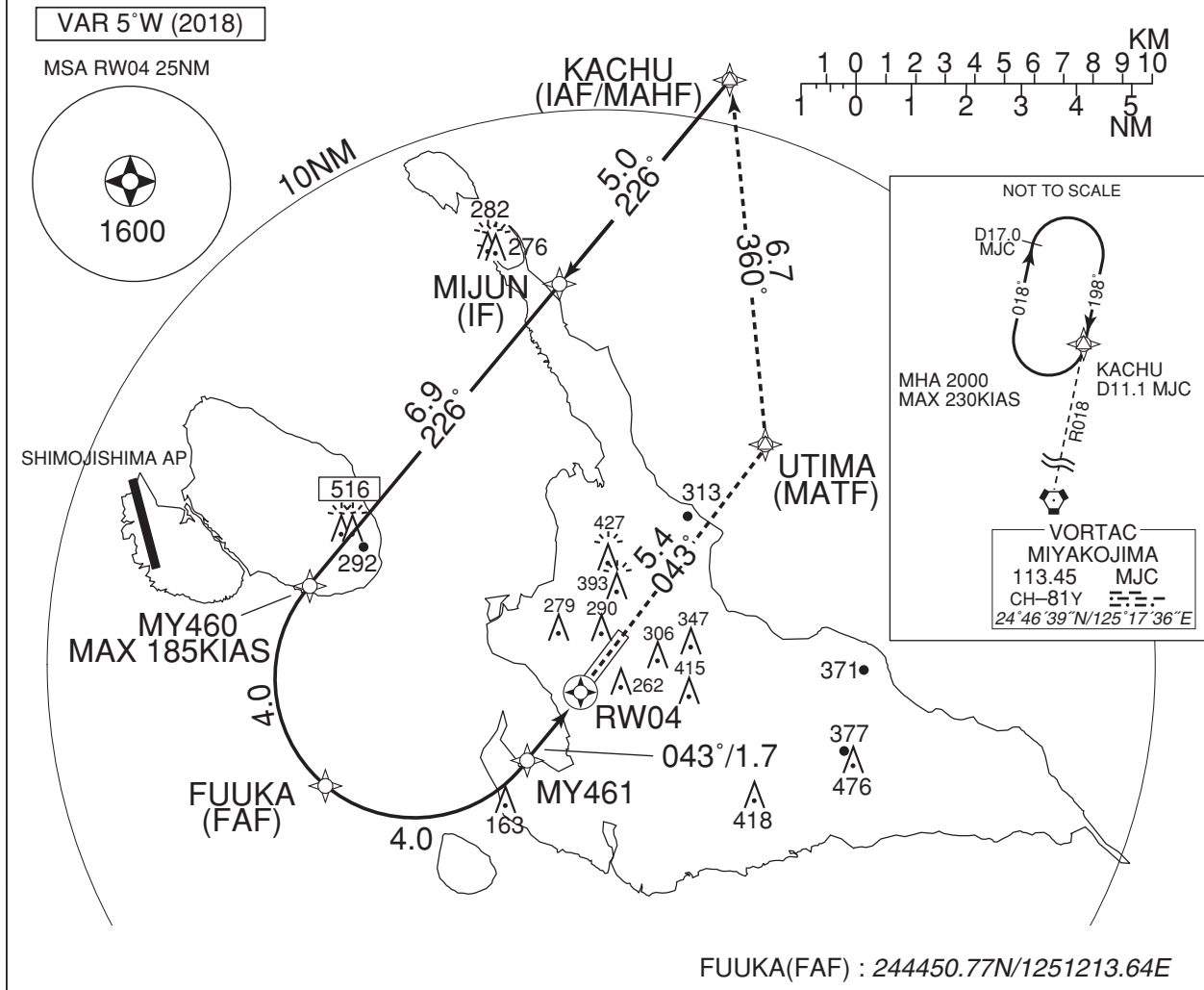

MINIMA	THR elev.124	AD elev.140		
CAT	RNP 0.29		RNP 0.30	
	DA(H)	CMV	DA(H)	CMV
A	-	-	-	-
B	-	-	-	-
C	424 (300)	1400	430 (306)	1400
D		1600	440 (316)	1600

RNP AR
Special Authorization Required

INSTRUMENT APPROACH CHART

ROMY / MIYAKO

RNAV(RNP) Y RWY04

RNAV(RNP) Y RWY04

Coding Table

Serial Number	Path Descriptor	Waypoint Identifier	Fly Over	Course °M(°T)	Magnetic Variation	Distance (NM)	Turn Direction	Altitude (FT)	Speed (KIAS)	VPA/RDH (°/FT)	RNP Value
001	IF	KACHU	-	-	-4.8	-	-	+2000	-	-	-
002	TF	MIJUN	-	226 (220.8)	-4.8	5.0	-	-	-	-	1.0
003	TF	MY460	-	226 (220.7)	-4.8	6.9	-	+2000	-185	-	1.0
004	RF Center: MYRF1 r=2.52NM	FUUKA	-	-	-4.8	4.0	L	2000	-	-	1.0
005	RF Center: MYRF1 r=2.52NM	MY461	-	-	-4.8	4.0	L	712	-	-3.00	0.29 0.30
006	TF	RW04	Y	043 (038.1)	-4.8	1.7	-	174	-	-3.00/50	0.29 0.30
007	TF	UTIMA	-	043 (038.2)	-4.8	5.4	-	-	-	-	1.0
008	TF	KACHU	-	360 (355.6)	-4.8	6.7	-	2000	-	-	1.0

Waypoint Coordinates

Waypoint Identifier	Coordinates	RF Arc Center Identifier	Coordinates
KACHU	245726.14N/1252027.95E	MYRF1	244646.77N/1251400.81E
MIJUN	245338.80N/1251651.84E		
MY460	244826.09N/1251155.10E		
FUUKA	244450.77N/1251213.64E		
MY461	244512.72N/1251611.26E		
RW04	244632.65N/1251720.41E		
UTIMA	245048.13N/1252101.67E		

INSTRUMENT APPROACH CHART

ROMY / MIYAKO

RNAV(RNP) X RWY04

SAKISHIMA APP 125.0 -121.2	GNSS and RF required.	MIYAKO TOWER 118.2 -126.2	RADAR AVBL
-------------------------------	-----------------------	------------------------------	------------

For uncompensated Baro-VNAV systems, procedure not authorized below 0°C / above 45°C

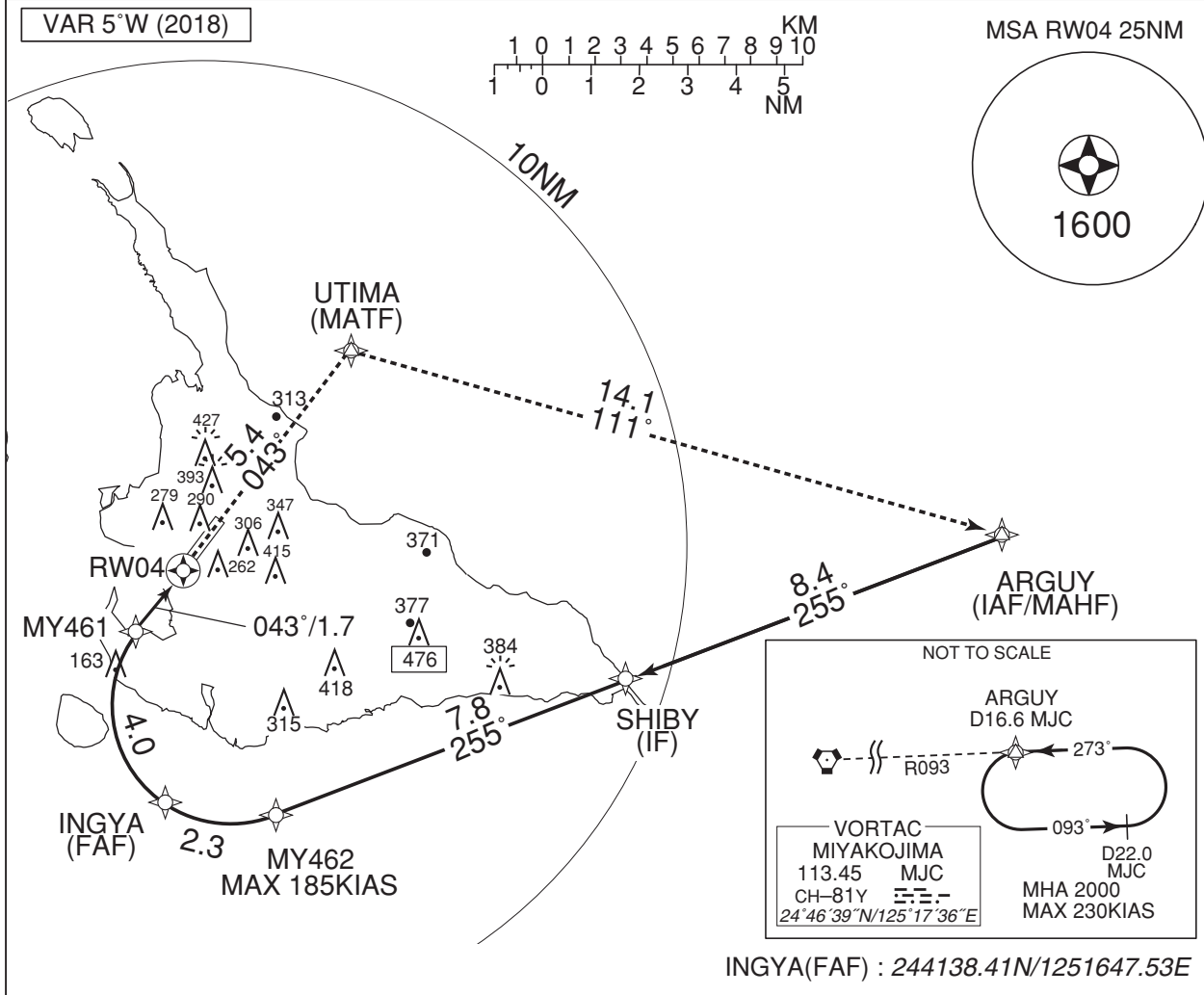

INGYA(FAF) : 244138.41N/1251647.53E

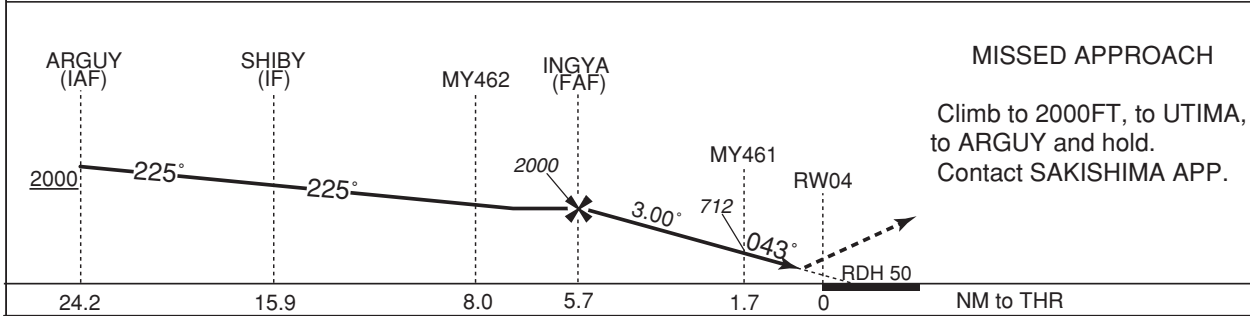

MISSED APPROACH

Climb to 2000FT, to UTIMA, to ARGUY and hold. Contact SAKISHIMA APP.

MINIMA	THR elev.124	AD elev.140		
CAT	RNP 0.29		RNP 0.30	
	DA(H)	CMV	DA(H)	CMV
A	-	-	-	-
B	-	-	-	-
C	424 (300)	1400	430 (306)	1400
D	424 (300)	1600	440 (316)	1600

RNP AR
Special Authorization Required

INSTRUMENT APPROACH CHART

ROMY / MIYAKO

RNAV(RNP) X RWY04

RNAV(RNP) X RWY04

Coding Table

Serial Number	Path Descriptor	Waypoint Identifier	Fly Over	Course 'M(^T)	Magnetic Variation	Distance (NM)	Turn Direction	Altitude (FT)	Speed (KIAS)	VPA/RDH (°/FT)	RNP Value
001	IF	ARGUY	-	-	-4.8	-	-	+2000	-	-	-
002	TF	SHIBY	-	255 (250.0)	-4.8	8.4	-	-	-	-	1.0
003	TF	MY462	-	255 (250.0)	-4.8	7.8	-	+2000	-185	-	1.0
004	RF Center: MYRF2 r=2.46NM	INGYA	-	-	-4.8	2.3	R	2000	-	-	1.0
005	RF Center: MYRF2 r=2.46NM	MY461	-	-	-4.8	4.0	R	712	-	-3.00	0.29 0.30
006	TF	RW04	Y	043 (038.1)	-4.8	1.7	-	174	-	-3.00/50	0.29 0.30
007	TF	UTIMA	-	043 (038.2)	-4.8	5.4	-	-	-	-	1.0
008	TF	ARGUY	-	111 (106.1)	-4.8	14.1	-	2000	-	-	1.0

Waypoint Coordinates

Waypoint Identifier	Coordinates	RF Arc Center Identifier	Coordinates
ARGUY	244652.87N/1253554.53E	MYRF2	244340.95N/1251818.44E
SHIBY	244401.74N/1252716.29E		
MY462	244121.83N/1251913.79E		
INGYA	244138.41N/1251647.53E		
MY461	244512.72N/1251611.26E		
RW04	244632.65N/1251720.41E		
UTIMA	245048.13N/1252101.67E		

STANDARD DEPARTURE CHART -INSTRUMENT

ROMY / MIYAKO

SID

NAHA SIX DEPARTURE

RWY 04 : Climb RWY HDG to 700FT, turn right...

RWY 22 : Climb RWY HDG to 600FT, turn left HDG015°...
... to intercept and proceed via MJC R060 to PAYAO.

PAYAO
D53.6 MJC

NAHA SIX DEPARTURE

060°

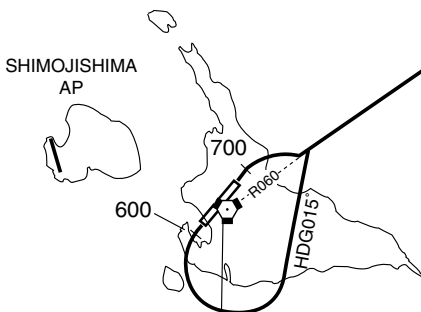

VORTAC
MIYAKOJIMA
113.45 MJC
CH-81Y
24°46'39"N/125°17'36"E
200FT

STANDARD DEPARTURE CHART -INSTRUMENT

ROMY / MIYAKO

SID

WEST SEVEN DEPARTURE

- RWY 04 : Climb RWY HDG to 700FT, turn right...
- RWY 22 : Climb RWY HDG to 600FT, turn right...
... to intercept and proceed via MJC R253 to SHUJI.
Cross SHUJI at or above 3000FT.

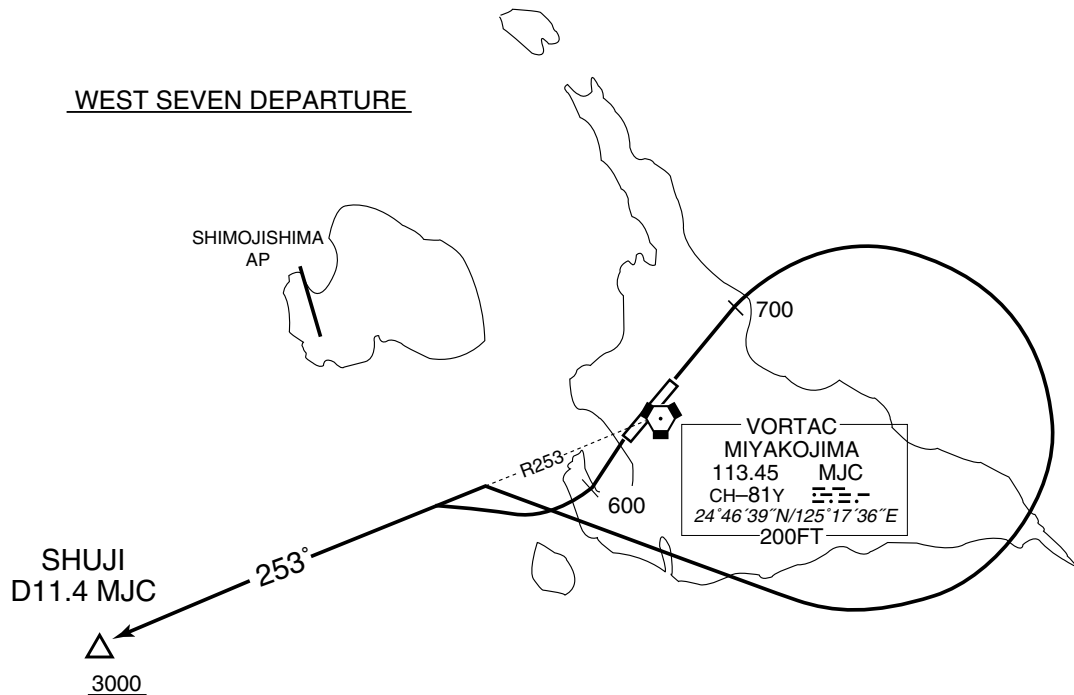

STANDARD DEPARTURE CHART -INSTRUMENT

ROMY / MIYAKO

RNAV SID

TORII TWO DEPARTURE		RNAV1
NOTE 1) GNSS required. 2) RADAR service required.	Critical DME	-
	DME GAP	RWY04 : DER - TORII RWY22 : DER - TORII
	Inappropriate Nav aids	See AD1.1.6.10.3. Inappropriate NAVAIDs for RNAV1.

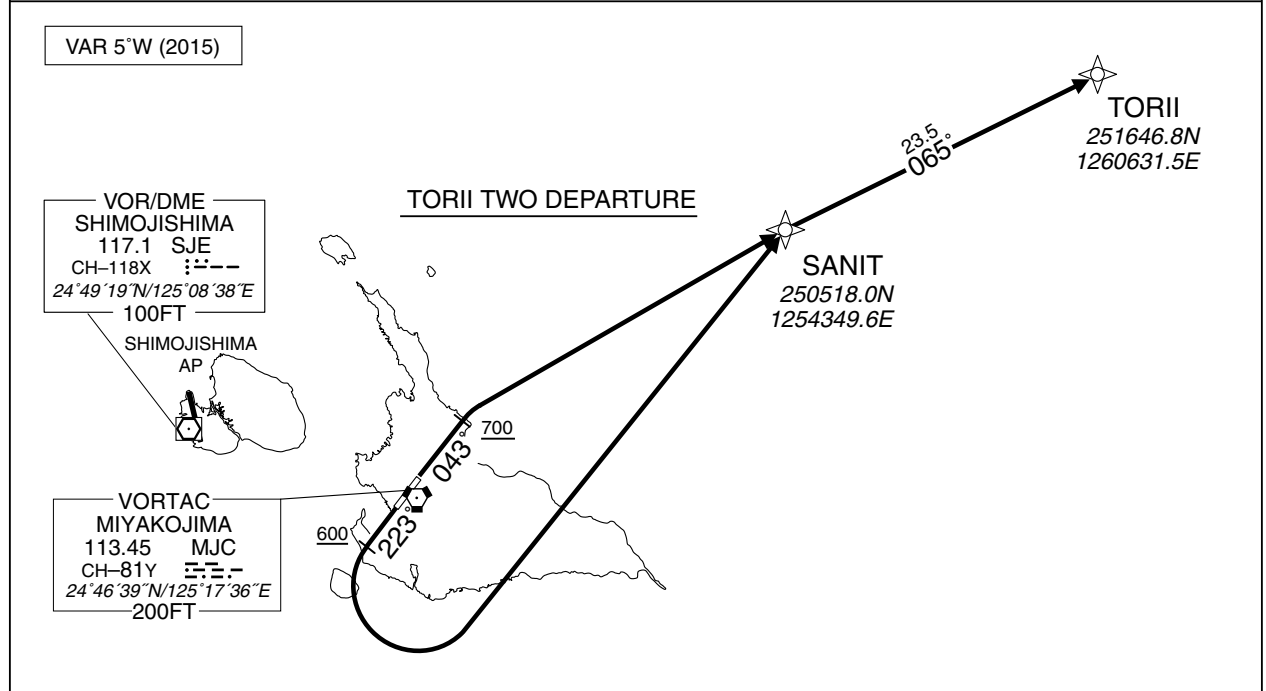

TORII TWO DEPARTURE

RWY04 : Climb on HDG043° at or above 700FT, turn right direct to SANIT, to TORII.
RWY22 : Climb on HDG223° at or above 600FT, turn left direct to SANIT, to TORII.

TORII TWO DEPARTURE

RWY04

Serial Number	Path Descriptor	Waypoint Identifier	Fly Over	Course °M(°T)	Magnetic Variation	Distance (NM)	Turn Direction	Altitude (FT)	Speed (KIAS)	Vertical Angle	Navigation Specification
001	VA	—	—	043 (038.2)	-4.5	—	—	+700	—	—	RNAV1
002	DF	SANIT	—	—	-4.5	—	R	—	—	—	RNAV1
003	TF	TORII	—	065 (060.7)	-4.5	23.5	—	—	—	—	RNAV1

RWY22

Serial Number	Path Descriptor	Waypoint Identifier	Fly Over	Course °M(°T)	Magnetic Variation	Distance (NM)	Turn Direction	Altitude (FT)	Speed (KIAS)	Vertical Angle	Navigation Specification
001	VA	—	—	223 (218.2)	-4.5	—	—	+600	—	—	RNAV1
002	DF	SANIT	—	—	-4.5	—	L	—	—	—	RNAV1
003	TF	TORII	—	065 (060.7)	-4.5	23.5	—	—	—	—	RNAV1

STANDARD DEPARTURE CHART -INSTRUMENT

ROMY / MIYAKO

RNAV SID and TRANSITION

UMAKI ONE DEPARTURE JOTTO TRANSITION / YUNTA TRANSITION		RNAV1
NOTE 1) DME/DME/IRU or GNSS required. ※ The aircraft equipped with only DME/DME/IRU must be able to update its position without delay at the starting point of take-off roll. 2) RADAR service required.	Critical DME	RWY04 : MJC, IGE : WAIDO - 23NM to UMAKI JOTTO TRANSITION : MJC : 22NM to YAIMA - 10NM to YAIMA IGE : 18NM to YAIMA - 10NM to YAIMA YNE : 22NM to YAIMA - 20NM to YAIMA YUNTA TRANSITION : IGE, YNE : 8NM to YUNTA - YUNTA
	DME GAP	RWY04 : DER - WAIDO, 23NM to UMAKI - UMAKI RWY22 : DER - UMAKI JOTTO TRANSITION : UMAKI - 22NM to YAIMA YUNTA TRANSITION : UMAKI - 8NM to YUNTA
	Inappropriate NavAids	See AD1.1.6.10.3. Inappropriate NAVAIDs for RNAV1.

CHANGE : VAR.TARAMA VOR/DME(RME) abolished. Course FM UMAKI to YUNTA. Course FM UMAKI to YAIMA.

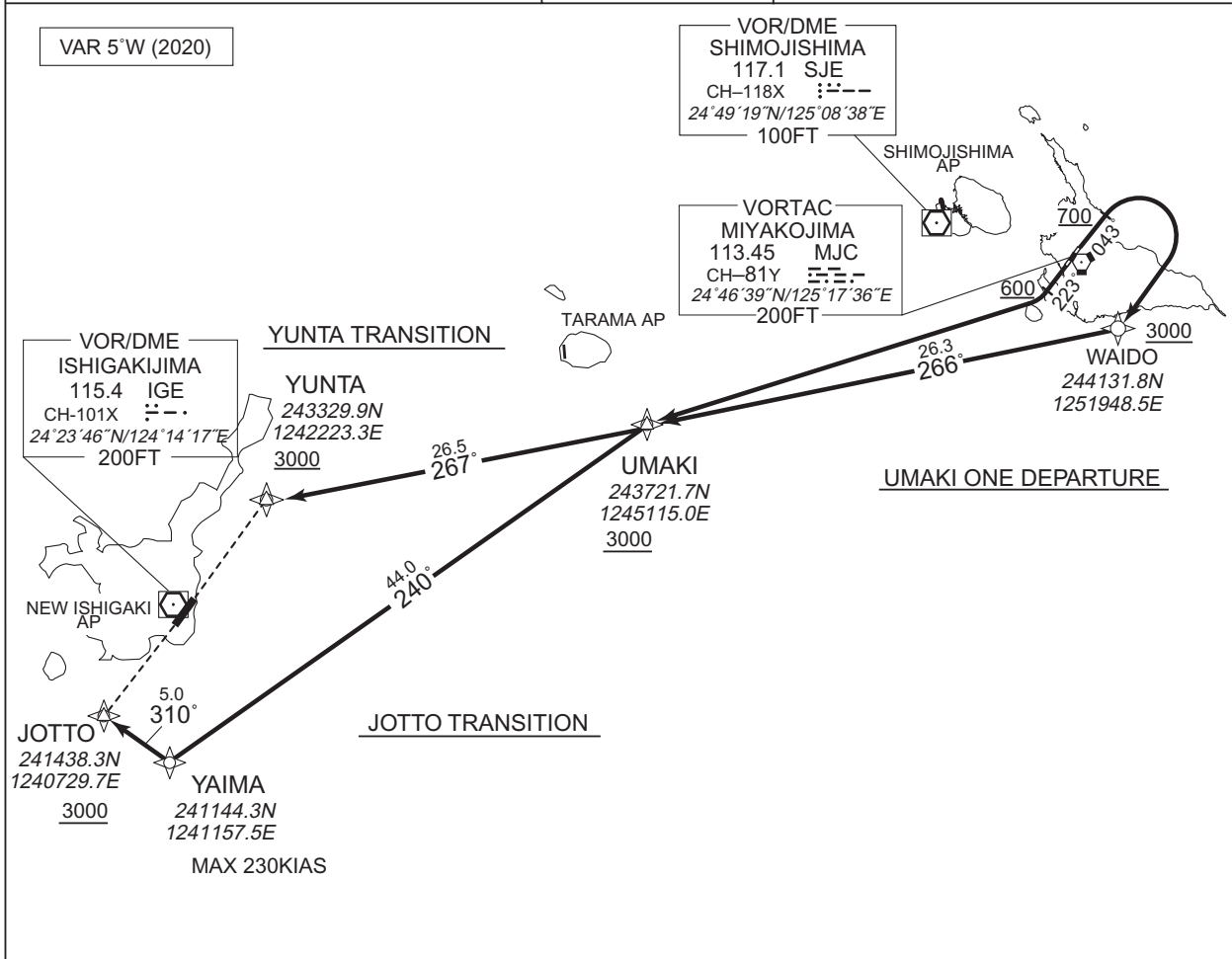

UMAKI ONE DEPARTURE
 RWY04 : Climb on HDG043° at or above 700FT, turn right direct to WAIDO at or above 3000FT, to UMAKI at or above 3000FT.
 RWY22 : Climb on HDG223° at or above 600FT, turn right direct to UMAKI at or above 3000FT.

YUNTA TRANSITION
 From UMAKI at or above 3000FT, to YUNTA at or above 3000FT.

JOTTO TRANSITION
 From UMAKI at or above 3000FT, to YAIMA, to JOTTO at or above 3000FT.

STANDARD DEPARTURE CHART -INSTRUMENT

ROMY / MIYAKO

RNAV SID and TRANSITION

UMAKI ONE DEPARTURE

RWY04

Serial Number	Path Descriptor	Waypoint Identifier	Fly Over	Course °M(°T)	Magnetic Variation	Distance (NM)	Turn Direction	Altitude (FT)	Speed (KIAS)	Vertical Angle	Navigation Specification
001	VA	-	-	043 (038.2)	-5.0	-	-	+700	-	-	RNAV1
002	DF	WAIDO	-	-	-5.0	-	R	+3000	-	-	RNAV1
003	TF	UMAKI	-	266 (261.0)	-5.0	26.3	-	+3000	-	-	RNAV1

RWY22

Serial Number	Path Descriptor	Waypoint Identifier	Fly Over	Course °M(°T)	Magnetic Variation	Distance (NM)	Turn Direction	Altitude (FT)	Speed (KIAS)	Vertical Angle	Navigation Specification
001	VA	-	-	223 (218.2)	-5.0	-	-	+600	-	-	RNAV1
002	DF	UMAKI	-	-	-5.0	-	R	+3000	-	-	RNAV1

YUNTA TRANSITION

Serial Number	Path Descriptor	Waypoint Identifier	Fly Over	Course °M(°T)	Magnetic Variation	Distance (NM)	Turn Direction	Altitude (FT)	Speed (KIAS)	Vertical Angle	Navigation Specification
001	IF	UMAKI	-	-	-5.0	-	-	+3000	-	-	RNAV1
002	TF	YUNTA	-	267 (261.7)	-5.0	26.5	-	+3000	-	-	RNAV1

JOTTO TRANSITION

Serial Number	Path Descriptor	Waypoint Identifier	Fly Over	Course °M(°T)	Magnetic Variation	Distance (NM)	Turn Direction	Altitude (FT)	Speed (KIAS)	Vertical Angle	Navigation Specification
001	IF	UMAKI	-	-	-5.0	-	-	+3000	-	-	RNAV1
002	TF	YAIMA	-	240 (234.5)	-5.0	44.0	-	-	-230	-	RNAV1
003	TF	JOTTO	-	310 (305.5)	-5.0	5.0	-	+3000	-	-	RNAV1

CHANGE : VAR. Course FM UMAKI to YUNTA. Course FM UMAKI to YAIMA.

INSTRUMENT APPROACH CHART

ROMY / MIYAKO

ILS Z or LOC Z RWY22

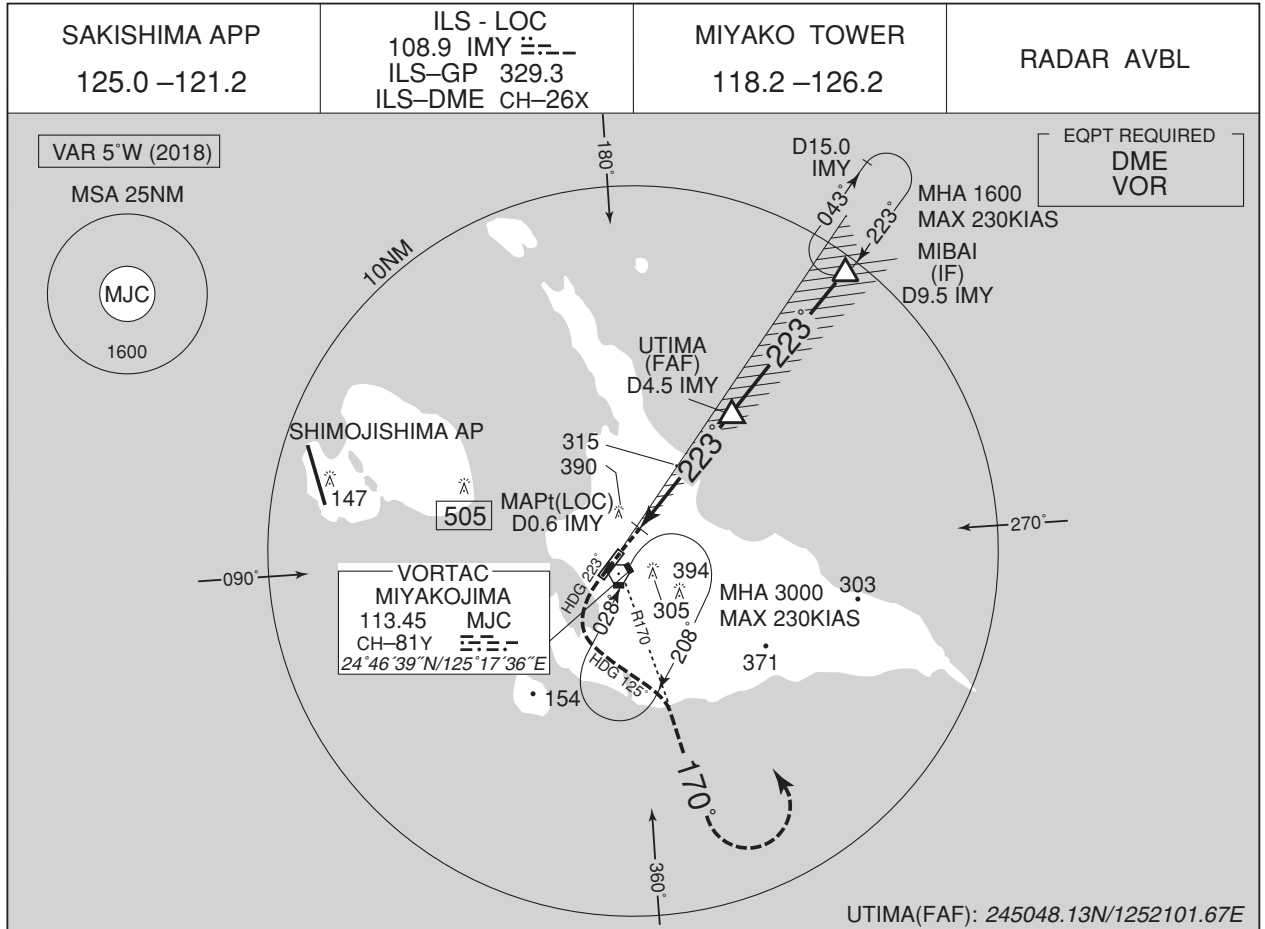

MISSED APPROACH
 Climb to 600FT on HDG 223°, turn left HDG 125° to intercept and proceed via MJC R170 to 2000FT, turn left, direct to MJC VORTAC and hold at 3000FT. Contact SAKISHIMA APP.
 Timing not authorized for defining the MAPt.

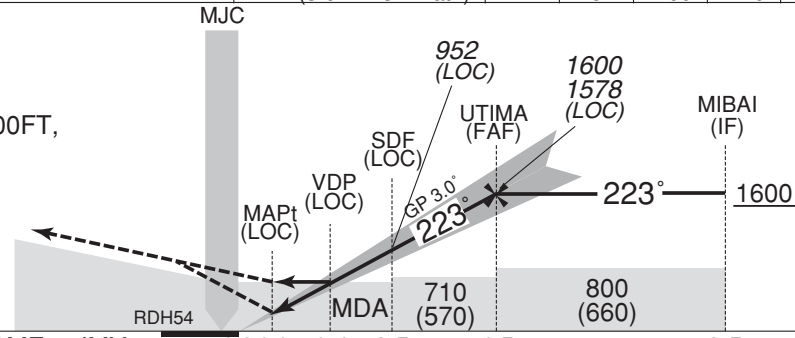

DME to IMY	0.2	0.6	1.4	2.5	4.5	9.5
NM to THR	0	0.4	1.3	2.4	4.3	9.3

MINIMA		THR elev. 150		AD elev. 140		
CAT	CAT I		LOC		CIRCLING	
	DA(H)	RVR/CMV	MDA(H)	RVR/CMV	MDA(H)	VIS
A	350 (200)	550	580 (440)	900	710 (570)	1600
B				1000		2400
C				1400		3200
D						

INSTRUMENT APPROACH CHART

ROMY / MIYAKO

ILS Y or LOC Y RWY22

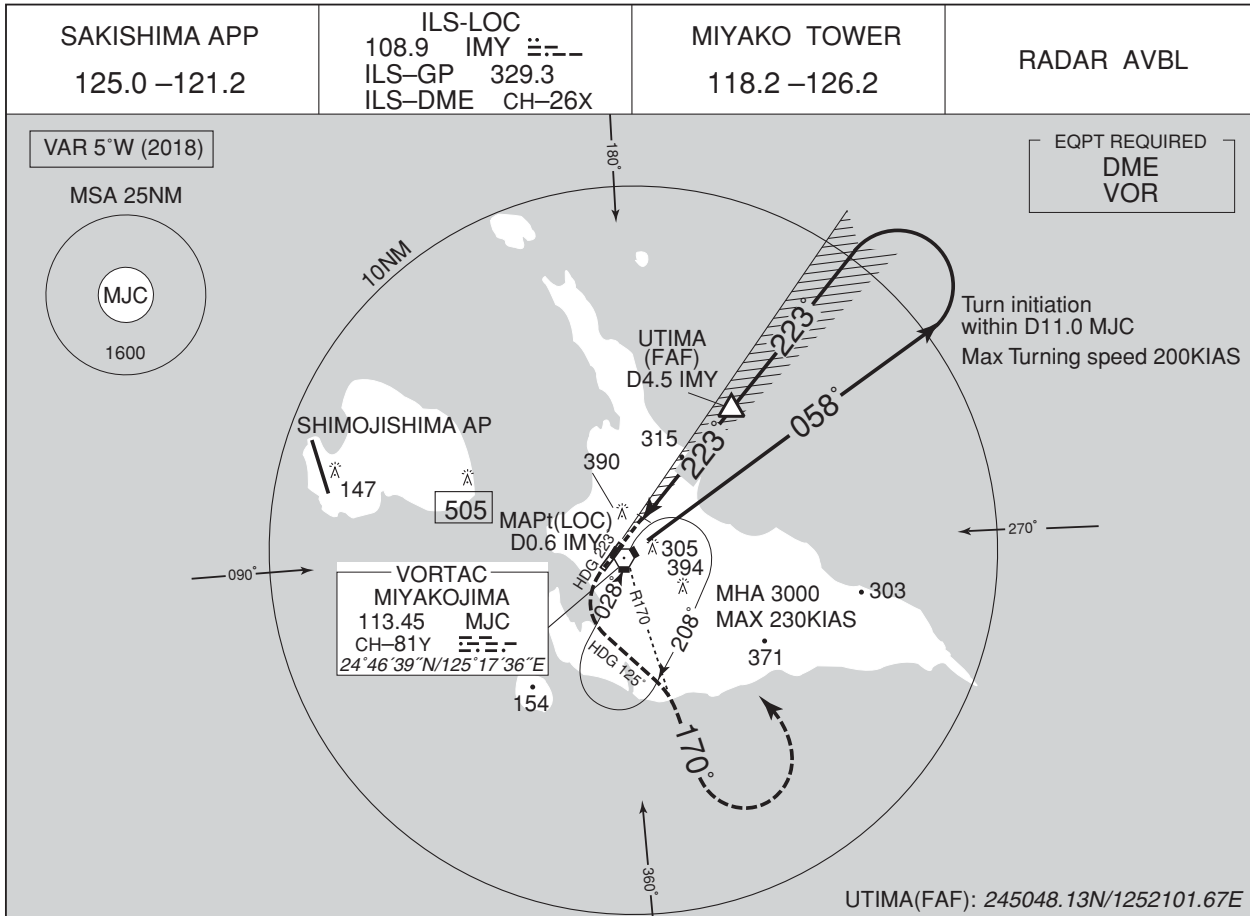

NM to IMY	MAPt	2	3	4	FAF
ALT (3.0° APCH Path)		781	1100	1419	1578

MISSED APPROACH

Climb to 600FT on HDG 223°, turn left HDG 125° to intercept and proceed via MJC R170 to 2000FT, turn left, direct to MJC VORTAC and hold at 3000FT. Contact SAKISHIMA APP.

Timing not authorized for defining the MAPt.

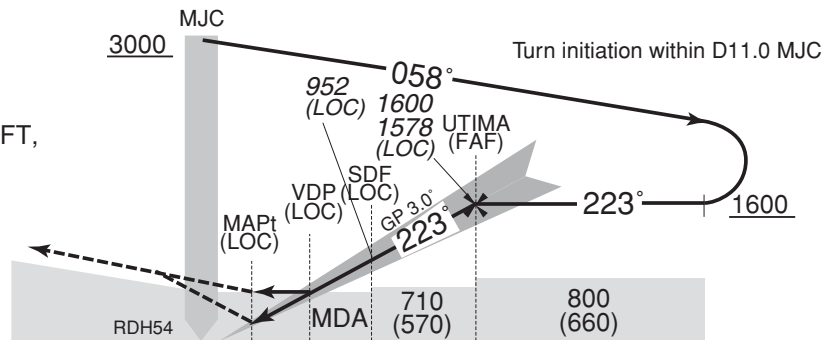

DME to IMY	0.2	0.6	1.4	2.5	4.5
NM to THR	0	0.4	1.3	2.4	4.3

MINIMA		THR elev. 150		AD elev. 140			
CAT	CAT I		LOC		CIRCLING		
	DA(H)	RVR/CMV	MDA(H)	RVR/CMV	MDA(H)	VIS	
A	350 (200)	550	580 (440)	900	710 (570)	1600	
B				1000			
C				1400			2400
D				1400			3200

ROMY / MIYAKO

Minimum Vectoring Altitude CHART

VAR 4°W (2013)

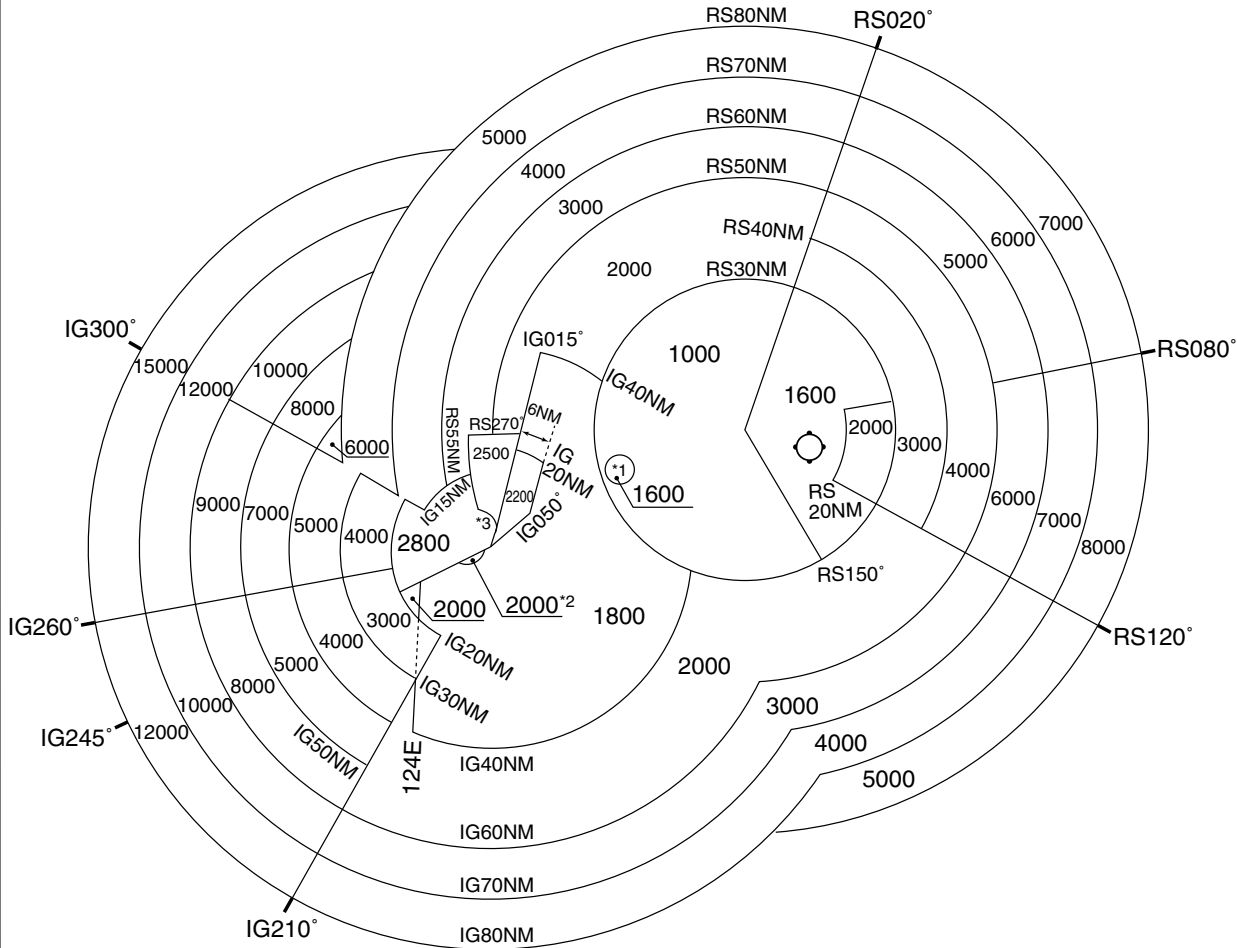

CENTER : 244938N/1250827E (RORS RADAR SITE)
CENTER : 242310N/1241441E (ROIG RADAR SITE)

- *1 : 244015N/1244143E RADIUS : 3NM
- *2 : 242248N/1240952E RADIUS : 3NM
- *3 : 242538N/1241100E RADIUS : 5NM

INSTRUMENT APPROACH CHART

ROMY / MIYAKO

VOR RWY04

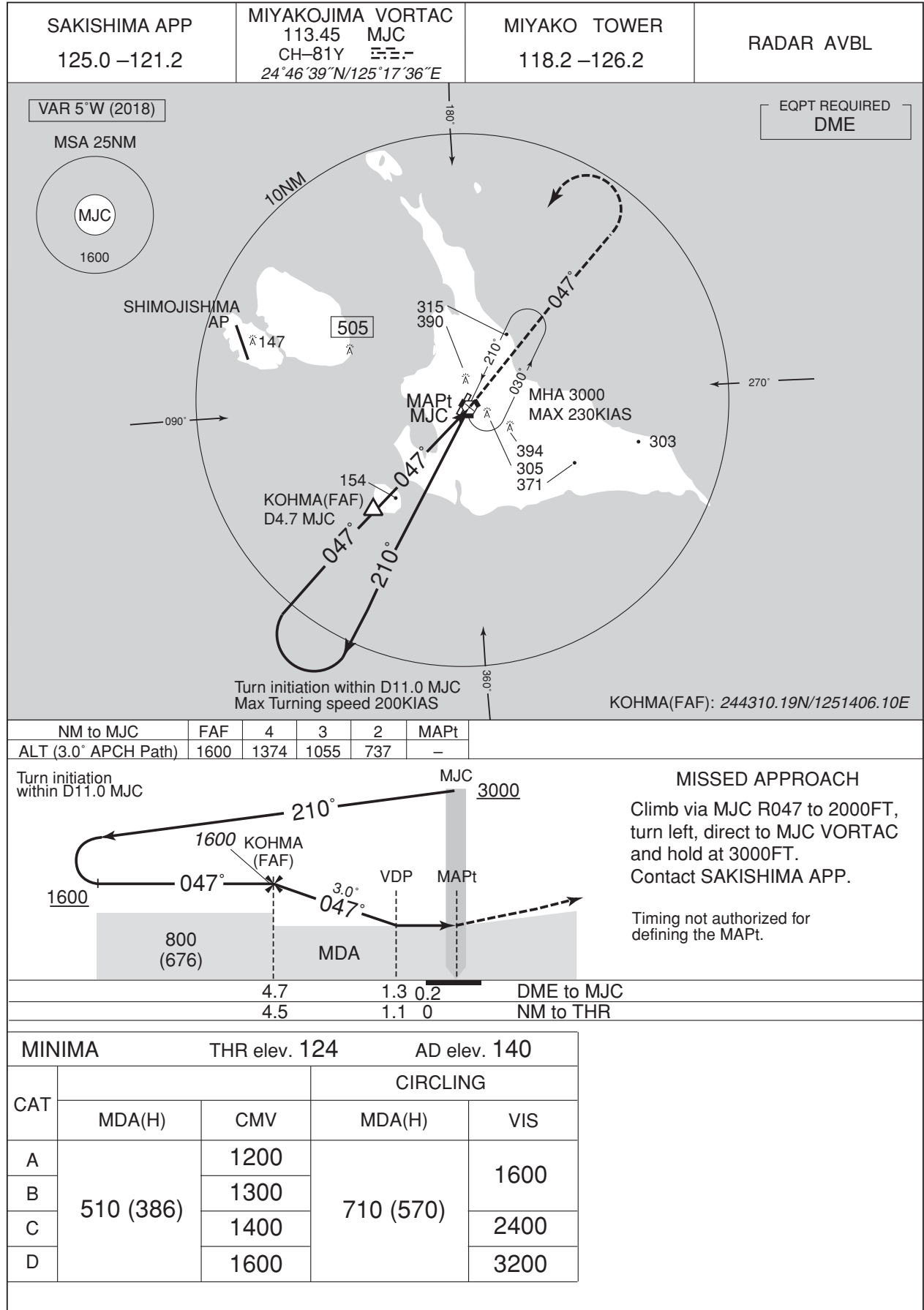

先島進入管制区
Sakishima Approach Control Area

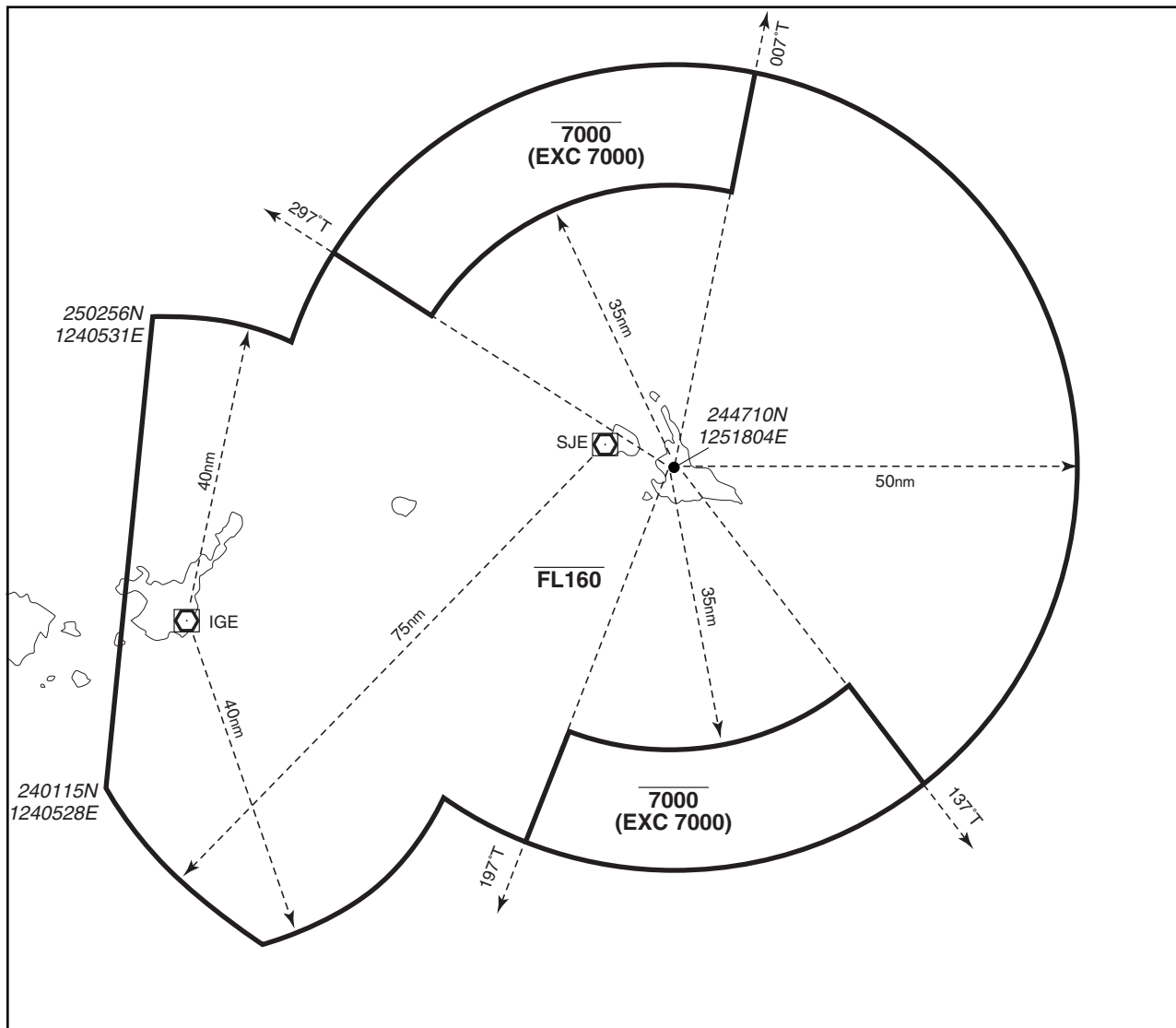

MIYAKO AIRPORT

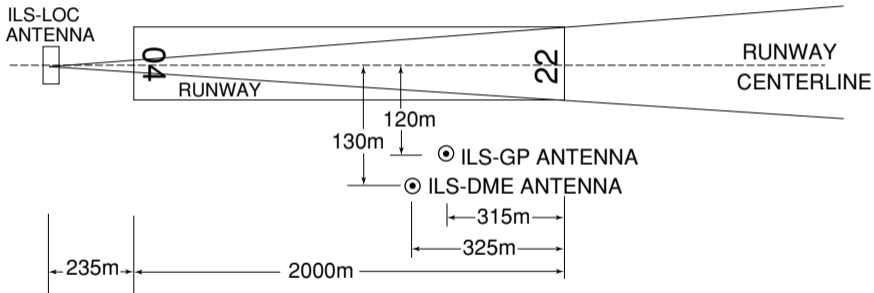

REMARKS : 1. ILS-LOC beam BRG(MAG) 223°
2. HGT of ILS REF datum 16.5m(54ft)
3. ILS-GP Angle 3.0°

B-767型機用の滑走路180° 旋回用標識(灯火)及び実施要項

付図に示す転回灯1が一直線に見えるように進行し、転回灯2が一直線に見えた時転回を開始する。

転回時はMAX STEERING ANGLEを使用する。

Marking(Lights)for 180° turn on runway of B-767 aircraft and Procedure using the Marking

Proceed along the RWY Turn Pad Center Line Marking to see the Turning Point Indicator Light 1 on a straight line, then commence turn at the spot where you (pilot) can see the Turning Point Indicator Light 2 on a straight line at an angle of 9 o'clock. When turning, take MAX STEERING ANGLE.

