

## AD 2 AERODROMES

## RJSM AD 2.1 AERODROME LOCATION INDICATOR AND NAME

## RJSM - MISAWA

## RJSM AD 2.2 AERODROME GEOGRAPHICAL AND ADMINISTRATIVE DATA

1	ARP coordinates and site at AD	404211N 1412206E
2	Direction and distance from (city)	3nm NE of Misawa Railway Station
3	Elevation/ Reference temperature	119ft / -
4	Geoid undulation at AD ELEV PSN	Nil
5	MAG VAR/ Annual change	8.7°W(2016)/ 0.0°W
6	AD Administration, address, telephone, telefax, telex, AFS, e-mail and/or Web-site addresses	USAF 35 OSS/OSAA Unit 5011 APO AP 96319-5011 Tel: 0176-77-1110 ext.226.3110 Fax: 0176-77-1110 ext.226.9145 e-mail: 35oss.amops@us.af.mil www.misawa.af.mil
7	Types of traffic permitted(IFR/VFR)	IFR/VFR
8	Remarks	Misawa Airport Office(Civil Aviation Bureau) Shimotazawa, Misawa, Aomori Prefecture TEL:0176-53-2461, 53-2463

## RJSM AD 2.3 OPERATIONAL HOURS

1	AD Administration	H24
2	Customs and immigration	On request Customs: 0178-33-0423 Immigration: 017-777-2939
3	Health and sanitation	Quarantine(human): On request(017-722-7687) Quarantine(animal, plant): Nil
4	AIS Briefing Office	Nil
5	ATS Reporting Office(ARO)	Nil
6	MET Briefing Office	H24(SENDAI)
7	ATS	H24
8	Fuelling	Nil
9	Handling	Nil
10	Security	Nil
11	De-icing	Nil
12	Remarks	HR of service at CAB OPS section 2330 - 1100

**RJSM AD 2.4 HANDLING SERVICES AND FACILITIES**

1	Cargo-handling facilities	Nil
2	Fuel/ oil types	JET A-1 (For CIV ACFT) , JET A-1 PLUS (For JSDF ACFT)
3	Fuelling facilities/ capacity	Fuel truck refueling(For CIV ACFT)
4	De-icing facilities	Nil
5	Hangar space for visiting aircraft	Nil
6	Repair facilities for visiting aircraft	Nil
7	Remarks	Nil

**RJSM AD 2.5 PASSENGER FACILITIES**

1	Hotels	In Misawa city
2	Restaurants	At the Airport, not continuous
3	Transportation	Buses, Taxis and Rent-a-car
4	Medical facilities	Hospitals in Misawa city
5	Bank and Post Office	In Misawa city
6	Tourist Office	In Misawa city
7	Remarks	Nil

**RJSM AD 2.6 RESCUE AND FIRE FIGHTING SERVICES**

1	AD category for fire fighting	CAT 10
2	Rescue equipment	(CAB) Emergency medical equipments conveyance truck x 1 Lighting power supply truck x 1
3	Capability for removal of disabled aircraft	Available via GOJ IAW Support Agreements
4	Remarks	Nil

**RJSM AD 2.7 SEASONAL AVAILABILITY-CLEARING**

1	Types of clearing equipment	Snow remove equipments *(CAB) : Rotary x 1, Loader x 2, Motor grader x 1, Anti-freezing sprayer x 1, Dump trucks, etc.
2	Clearance priorities	Nil
3	Remarks	*For Civil apron and TWY A8

**RJSM AD 2.8 APRONS, TAXIWAYS AND CHECK LOCATIONS DATA**

1	Apron surface and strength	Civil apron : Surface : Cement Concrete, Strength : PCN 50/R/C/X/T
2	Taxiway width, surface and strength	A: Width 23m      Surface: Concrete      Strength: PCN 54/R/B/W/T A1: Width 96m      Surface: Concrete      Strength: PCN 71/R/A/W/T A2: Width 66m      Surface: Concrete      Strength: PCN 72/R/B/W/T A3: Width 23m      Surface: Concrete      Strength: PCN 45/R/B/W/T A4: Width 23m      Surface: Asphalt      Strength: PCN 65/F/C/W/T A5: Width 55m      Surface: Concrete      Strength: PCN 42/R/B/W/T B1: Width 91m      Surface: Concrete      Strength: PCN 53/R/B/W/T B2: Width 23m      Surface: Asphalt      Strength: PCN 44/R/C/W/T B3: Width 23m      Surface: Asphalt      Strength: PCN 38/R/C/W/T B5: Width 23m      Surface: Concrete      Strength: PCN 58/R/B/W/T BRAVO: Width 23m      Surface: Concrete      Strength: PCN 23/R/C/W/T  Civil TWY A8 : Width 23m Surface : Cement Concrete, Strength : PCN 50/R/C/X/T Surface : Asphalt Concrete, Strength : PCN 48/F/B/X/T
3	ACL and elevation	Not available
4	VOR checkpoints	TWY A1, A2, B1
5	INS checkpoints	Nil
6	Remarks	Nil

**RJSM AD 2.9 SURFACE MOVEMENT GUIDANCE AND CONTROL SYSTEM AND MARKINGS**

1	Use of aircraft stand ID signs, TWY guide lines and Visual docking / parking guidance system of aircraft stands	Nil
2	RWY and TWY markings and LGT	RWY: RWY10/28 (Marking): RWY designation, RWY CL, RWY THR, RWY THR stripe, Fixed DIST, TDZ, RWY Side stripe, RWY lead-on/lead-off lines, RWY Shoulder (LGT): RTHL, REDL, RENL, RWY DIST marker LGT, Arresting gear marker (AGM), RWY guard LGT (elev WIG-WAG)  TWY: ALL TWY (EXC A8) (Marking): TWY side stripe, TWY CL (LGT): TWY edge LGT, TWY end LGT, Taxiing Guidance Sign  Civil TWY: A8 (Marking): TWY side stripe, TWY CL (LGT): TWY edge LGT, TWY CL LGT
3	Stop bars	Nil
4	Remarks	Civil apron: (LGT): Apron flood LGT

**RJSM AD 2.10 AERODROME OBSTACLES**

In circling area and at AD

Obstacle type	Coordinates	Elevation	Markings/ LGT	Remarks
Airfield Beacon/Water Tower	404115.9N 1412138.3E	293FT MSL		

**RJSM AD 2.11 METEOROLOGICAL INFORMATION PROVIDED**

1	Associated MET Office	SENDAI
2	Hours of service MET Office outside hours	H24(SENDAI)
3	Office responsible for TAF preparation Periods of validity	Nil
4	Trend forecast Interval of issuance	Nil
5	Briefing/ consultation provided	Briefing is available upon inquiry at SENDAI
6	Flight documentation Language(s) used	C En
7	Charts and other information available for briefing or consultation	S <sub>6</sub> , U <sub>85</sub> , U <sub>7</sub> , U <sub>5</sub> , U <sub>3</sub> , U <sub>25</sub> , U <sub>2</sub> /T <sub>r</sub> , P <sub>S</sub> , P <sub>5</sub> , P <sub>3</sub> , P <sub>25</sub> , P <sub>SWE</sub> , P <sub>SWF</sub> , P <sub>SWG</sub> , P <sub>SWI</sub> , P <sub>SWM</sub> , P <sub>SW</sub> (domestic), E, C, W <sub>E</sub> , W <sub>F</sub> , W <sub>G</sub> , W <sub>I</sub> , W <sub>N</sub>
8	Supplementary equipment available for providing information	Doppler Radar for Airport Weather (See below figure)
9	ATS units provided with information	TWR, APP, ATIS
10	Additional information (limitation of service, etc.)	Observation is made by the Ministry of Defence.

**Airspace for the advisory service concerning low level wind shear**

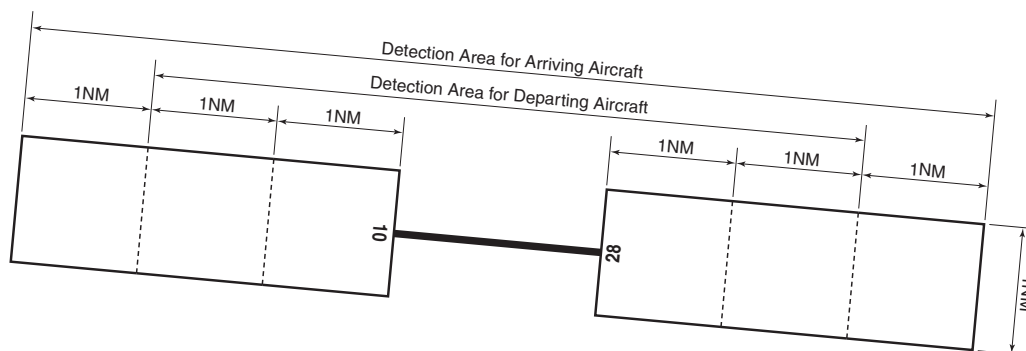

UPPER LIMIT: 1600ft above FIELD ELEV LEVEL  
LOWER LIMIT: FIELD ELEV LEVEL

**RJSM AD 2.12 RUNWAY PHYSICAL CHARACTERISTICS**

Designations RWY NR	TRUE BRG	Dimensions of RWY(M)	Strength(PCN) and surface of RWY	THR coordinates THR geoid undulation	THR elevation and highest elevation of TDZ of precision APP RWY
1	2	3	4	5	6
10	to be issued later	3050×45	PCN 47/R/B/W/T Asphalt Concrete	404215.991N 1412101.361E	THR 114FT TDZ 116FT
28	to be issued later	3050×45	PCN 47/R/B/W/T Asphalt Concrete	404207.194N 1412310.850E	THR 94FT TDZ 98FT
Slope of RWY		Strip Dimensions(M)		Remarks	
7		10		12	
from the crown of the RWY -0.26		3650×600		Nil	
from the crown of the RWY -0.148		3650×600			

**RJSM AD 2.13 DECLARED DISTANCES**

RWY Designator	TORA (m)	TODA (m)	ASDA (m)	LDA (m)	Remarks
1	2	3	4	5	6

**RJSM AD 2.14 APPROACH AND RUNWAY LIGHTING**

RWY Designator	APCH LGT type LEN INTST	RTHL Color WBAR	PAPI (VASIS) Angle DIST FM THR MEHT	RTZL LEN	RCLL LEN Spacing Color INTST	REDL LEN Spacing Color INTST	RENL Color WBAR	STWL LEN Color
1	2	3	4	5	6	7	8	9
10	ALSF-1 900m	Green Green	PAPI 3.00°/Left 947ft	Nil	Nil	2440m 60m coded color Yellow/White LIH	Red Red	Nil
28	ALSF-1 900m	Green Green	PAPI 2.37°/Left 1113ft	Nil	Nil	2440m 60m coded color Yellow/White LIH	Red Red	Nil
Remarks								
10								
RWY28 PAPI and ILS GS not coincidental. PAPI for RWY28 unuse beyond 8° right of RWY CL.								

## RJSM AD 2.15 OTHER LIGHTING, SECONDARY POWER SUPPLY

1	ABN/IBN location, characteristics and hours of operation	ABN: 404108N/1412145E , White/Green EV10sec, HN&HO
2	LDI location and LGT Anemometer location and LGT	Nil
3	TWY edge and centerline lighting	TWY edge LGT for A8:AVBL TWY CL LGT for A8:AVBL
4	Secondary power supply/ switch-over time	Nil
5	Remarks	Nil

## RJSM AD 2.16 HELICOPTER LANDING AREA

Nil
-----

## RJSM AD 2.17 ATS AIRSPACE

Designation and lateral limits		Vertical limits (ft)	Airspace classification	ATS unit call sign Language	Remarks
1		2	3	4	6
MISAWA CTR	Area within a radius of 5nm of MISAWA ARP (40°42'N/141°22'E)	6000 or below	D	MISAWA TOWER En	
MISAWA PCA	SEE ATTACHED CHART		C	SEE ATTACHED CHART	
MISAWA ACA	SEE ATTACHED CHART		E		
MISAWA TCA	SEE ATTACHED CHART		E		

Misawa Positive Control Area

NAME	LATERAL LIMITS	UPPER LIMIT (AMSL)	UNIT PROVIDING SERVICE	REMARKS
		LOWER LIMIT (AMSL) M(ft)		
1	2	3	4	5
三沢 Misawa	<p>下記に示される区域 The area shown below</p> <p>(1) 三沢第一特別管制区 Misawa NR 1 Positive Control Air Space</p> <p>(2) 三沢第二特別管制区 Misawa NR 2 Positive Control Air Space</p>		<p>札幌ACC Sapporo ACC 124.5 MHz 303.8 MHz</p> <p>三沢アプローチ Misawa APP RADAR</p> <p>Primary 120.7 MHz 317.8 MHz</p> <p>Secondary 261.2MHz</p>	<p>当該空域を飛行しようとする VFR機は、札幌ACCに連絡し 、飛行の許可を求めること。 VFR aircraft operating which will fly in the airspace above should contact Sapporo ACC and obtain the permission.</p> <p>当該空域を飛行しようとする VFR機は、三沢アプローチ又 はレーダーに連絡し、飛行の 許可を求めること。 VFR aircraft operating which will fly in the airspace above should contact Misawa APP/RADAR and obtain the permission.</p>

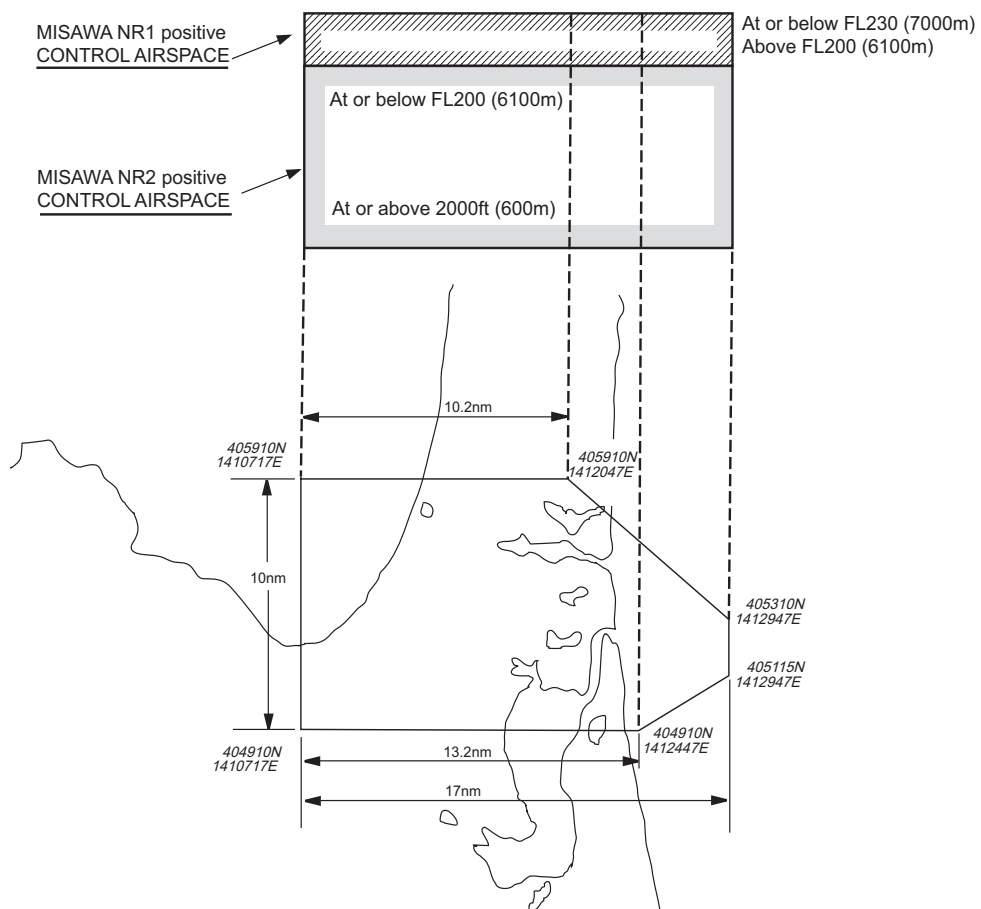

Misawa Approach Control Area

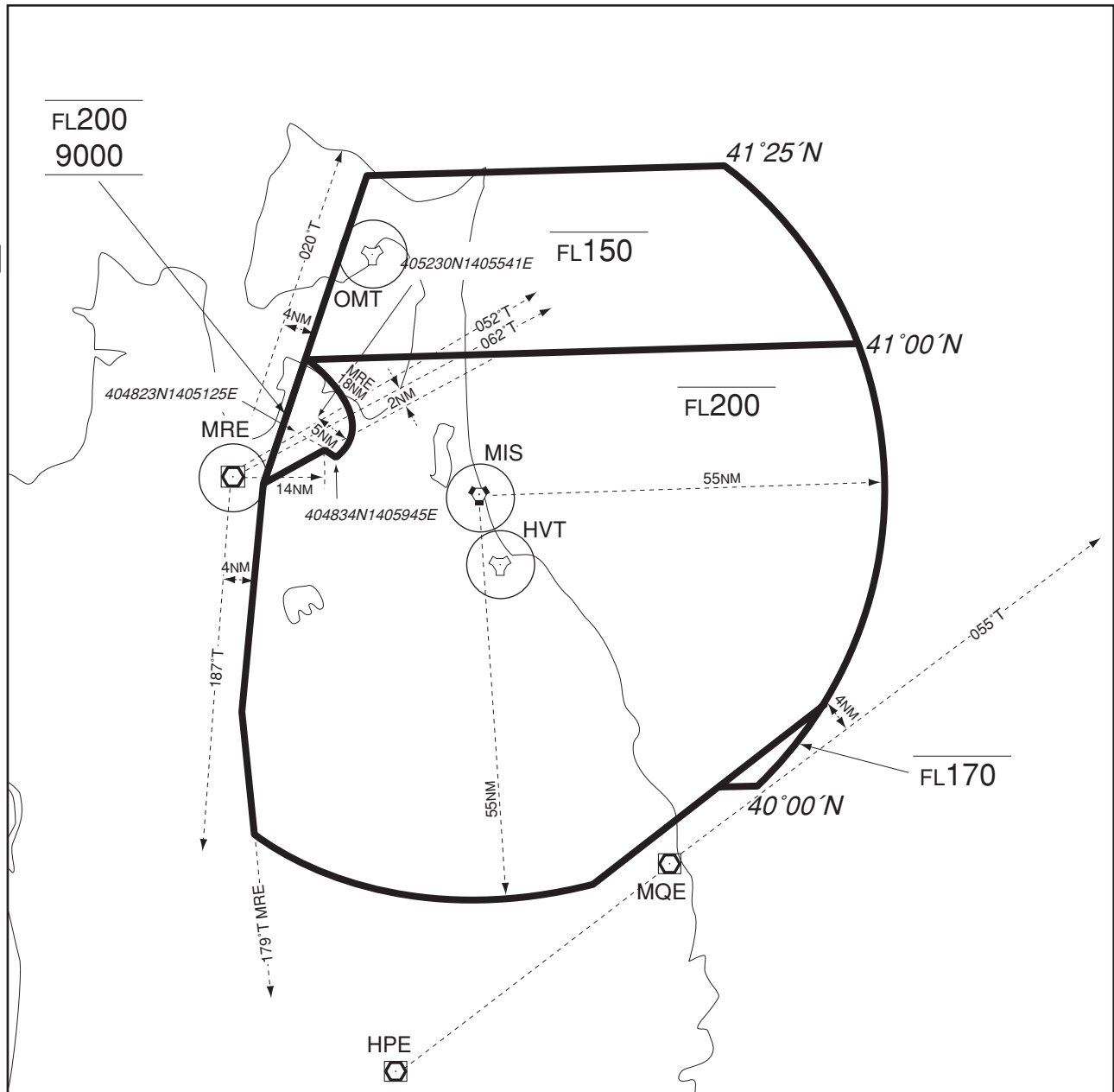



Misawa Terminal Control Area

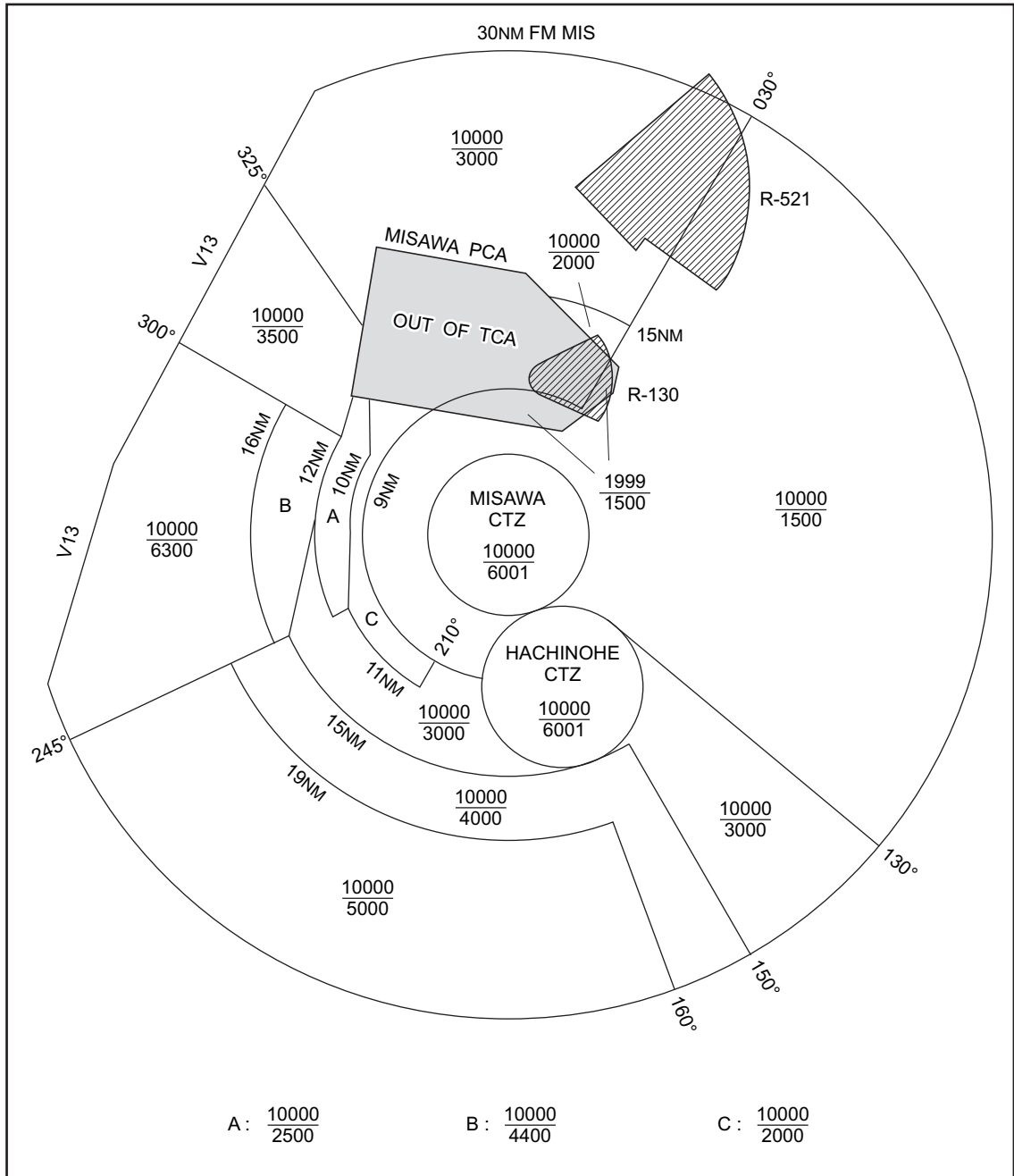

## RJSM AD 2.18 ATS COMMUNICATION FACILITIES

Service designation	Call sign	Frequency	Hours of operation	Remarks
1	2	3	4	5
APP/ASR	Misawa Approach/ Misawa Radar	317.8MHz(1) 261.2MHz(1) 362.3MHz(2) 120.7MHz(1) 120.1MHz(2) 243.0MHz(E) 121.5MHz(E)	H24	(1) VFR Radar advisory SER all ALT. (2) AVBL on request. (3) CLR delivery. (4) For rescue only.
TCA	Misawa TCA	124.05MHz 288.1MHz	2300 - 1100 MON-FRI	(5) Secondary.
DEP	Misawa Departure	363.8MHz(1) 125.3MHz(1)	H24	
TWR	Misawa Tower	315.8MHz 236.8MHz(5) 236.6MHz(2) 126.2MHz(5) 118.1MHz 138.05MHz(4) 247.0MHz(2)(4) 123.1MHz(2)(4) 121.5MHz(E) 243.0MHz(E)	H24	
GCA-ASR -PAR	Misawa Radar	258.2MHz 261.0MHz 270.8MHz 289.4MHz 335.8MHz 335.6MHz  134.1MHz 139.4MHz 125.15MHz 127.95MHz 121.5MHz(E) 243.0MHz(E)	H24	ASR, PAR RWY 10/28 Glide path 3.0° RWY10 Glide path 2.5° RWY28 Maintenance period: 2300-0300 FRI in VMC.  if COM is lost on westerly HDG on downwind leg of radar APCH to RWY10, do not exceed 12 DME of MIS.
GND	Misawa Ground	275.8MHz(3)  126.2MHz(2) 118.65MHz(3)	H24	
ATIS	Misawa Airport	128.4MHz 315.35MHz	2200 - 1100 MON-FRI	
MET	Misawa Metro	344.6MHz	H24	PFSV

RJSM AD 2.19 RADIO NAVIGATION AND LANDING AIDS

Type of aid	ID	Frequency	Hours of operation	Position of transmitting antenna coordinates	Elevation of DME transmitting antenna	Remarks
1	2	3	4	5	6	7
VOR (8° 30.0' W)	MIS	115.4MHz	H24	404213.76N 1412251.99E		VOR Unusable: (1) R050-100 beyond 25nm BLW 5500ft. (2) R135-200 WI 20nm BLW 5500ft beyond 20nm BLW 15000ft. (3) R240-280 beyond 30nm BLW 9500ft. (4) R310-350 beyond 20nm all ALT. VOR Maintenance period: 1500-2200Z(SUN-THU)
TACAN (8° 30.0' W)	MIS	Tx1188MHz (CH-101)	H24	404213.76N 1412251.99E	142ft	TACAN AZM and DME Unusable: 050°-065° beyond 25nm BLW 3000ft. TACAN DME unusable: 260°-275° beyond 39nm. TACAN Maintenance period: 1500-2200Z(SUN-THU)
ILS-LOC 28	I-MIS	109.7MHz	H24	-		LOC back course unusable for course guidance.
ILS-GP 28	-	333.2MHz	H24	-		ILS RWY 10/28 Maintenance period: 1500-2200Z(SUN-THU)
ILS-LOC10	I-MAS	109.7MHz	H24			
ILS-GP10		333.2MHz	H24			

**RJSM AD 2.20 LOCAL TRAFFIC REGULATIONS**

## 1. Airport regulations

1. Do not overfly Misawa City located S of AB below 3000FT VMC.
2. Do not overfly school building located APRX 1.5NM ESE of AB.
3. On take off all ACFT (including radar vectored ACFT) must MNTN RWY HDG at or below 1600FT until 3 DME for RWY28 or 2 DME for RWY10 unless otherwise cleared by ATC.

## 2. Taxiing to and from stands

TKOF restriction:  
To prevent jet blast damage to over run, all TKOF and ENG run by jet ACFT shall be performed at least 200ft FM RWY THR.

## 3. Parking area for small aircraft(General aviation)

Nil

## 4. Parking area for helicopters

Nil

## 5. Apron - taxiing during winter conditions

Nil

## 6. Taxiing - limitations

1. Alpha Taxilane is located between TWY A1 and A4 and is restricted to aircraft with wingspans of 170ft (C-17) or smaller. Aircraft with wingspans larger than 170ft requiring the use of Alpha Taxilane must receive approval from the AFM prior to use.
  2. TWY B between B2 and B5 restricted to C130, P8, CH-47 or smaller aircraft. B-737 operations authorized on full length of TWY B. Any other use requires coordination with the AFM and/or CES pavement engineer.
- NOTE: Intersection of TWY B and C3/B3 unrestricted.

## 7. School and training flights - technical test flights - use of runways

Nil

## 8. Helicopter traffic - limitation

Nil

## 9. Removal of disabled aircraft from runways

Nil

**RJSM AD 2.21 NOISE ABATEMENT PROCEDURES**

1. Local established ACFT quiet HR at Misawa 1300-2100Z DLY. No ENG runs, ARR or DEP WO prior COOR approval; policy strictly enforced.
2. The south departure ACFT will delay turns until 3.5 DME for RWY28 and 2.5 DME for RWY10.

**RJSM AD 2.22 FLIGHT PROCEDURES**

**1. Automated Radar Terminal System(ARTS)**

三沢進入管制所の指示のもとに、当該進入管制区を飛行する航空機は、モード A/3 の二次レーダー個別コード及びモード C による応答を指示される。二次レーダー個別コードを搭載していない航空機が当該コードによる応答を指示された場合は、管制官に対し、その旨通報すること。

Aircraft flying within the approach control area under the control of Misawa approach control will be instructed to reply with discrete code on Mode A/3 and Mode C.

If an aircraft with non-discrete code capability be instructed to reply with the discrete code, it shall report a controller accordingly.

**2.WX MINIMA CONCERNING PAR/ASR APCH PROCEDURE**

	<b>RWY</b>	<b>GS/TCH/RPI</b>	<b>CAT</b>	<b>DH/ MDA-VIS</b>	<b>HAT/HATh HAA</b>	<b>CEIL-VIS</b>
PAR ②	28 ④	3°/-/-	ABCDE	<b>209/18</b>	100	(100-¼)
	10 ⑤	3°/-/-	ABCDE	<b>219/24</b>	100	(100-¼)
ASR ②	10 ⑥		ABCDE	<b>480/40</b>	371	(400-¾)
	28 ⑦		ABC	<b>540/40</b>	431	(500-¾)
			DE	<b>540/50</b>	431	(500-1)
CIR ③	10-28		A	<b>540-1¼</b>	421	(500-1¼)
			B	<b>580-1¼</b>	461	(500-1¼)
			C	<b>580-1½</b>	461	(500-1½)
			DE	<b>680-2</b>	561	(600-2)

① a. LOST COMMUNICATIONS: If no transmissions are received for more than 30 seconds for Rwy 10 (1 minute for Rwy 28) during radar vectors to final, or for more than 5 seconds/15 seconds once established on PAR/ASR final approach, the pilot shall maintain VMC and attempt to contact Misawa Tower. If unable to maintain VMC, the pilot shall proceed to SHOJU IAF for the runway of departure, at last assigned alt or 9000, whichever is higher, and execute instrument approach or previously coordinated instruction.

① b. If com is lost on westerly hdg on downwind leg of radar apch to Rwy 10, do not exceed 10.7 mile fix of MISAWA VORTAC. CAUTION: Possible interference on freq 270.8 from Chitose. ② MP 2300-0300Z Fri. ③ Cir not auth S of Rwy 10-28. ④ When ALS inop, increase RVR to 24, vis to ½. ⑤ When ALS inop, increase RVR to 40, vis to ¾. ⑥ When ALS inop, increase vis CAT ABC RVR to 50, vis to 1 mile, CAT DE RVR to 60, vis to 1¼. ⑦ When ALS inop, increase CAT AB RVR to 50, vis to 1 mile, CAT C RVR to 60, vis to 1¼, CAT DE vis to 1½.

NOTE:REPRINTING DOD FLIP

## RJSM AD 2.23 ADDITIONAL INFORMATION

1. 無操縦者航空機の飛行について		1.Unmanned aircraft operations	
1.1 三沢飛行場周辺の空域において、無操縦者航空機の飛行が次のとおり実施される。		1.1 Unmanned aircraft operations will take place in the vicinity of Misawa aerodrome as follows	
航空機	RQ-4(グローバル・ホーク) : unmanned aircraft の用語が使用される。	Aircraft	RQ-4(Global Hawk) : Term "unmanned aircraft" is used.
区域	添付図参照	AREA	See attached chart
飛行方式	計器飛行方式	Flight Rules	IFR
高度	1,000ft から 29,000ft まで	Altitude	1,000ft to 29,000ft
期間	飛行予定時間はノータムにより通知される	Period	Expected date and time for the operations will be notified by NOTAM.
1.2 三沢飛行場周辺の空域において飛行する航空機は次の対応が求められる。		1.2 The aircraft flying in the vicinity of Misawa aerodrome will be required following action.	
(1) 有視界飛行方式により当該空域に入域する際は、事前に ATIS の聴取又は管制機関 (20,000 フィート以下の場合は三沢進入管制所、20,000 フィートを超える場合は札幌管制部) との通信設定を行い、無操縦者航空機の運航の有無を確認すること。(“unmanned aircraft operations are in progress” の用語が三沢 ATIS の備考に追加される。)		(1)A VFR aircraft should monitor Misawa ATIS or contact Misawa APP/ASR at or below 20,000 feet or SAPPORO-ACC above 20,000 feet before entering the area and check the unmanned aircraft operations.(Misawa ATIS will broadcast "unmanned aircraft operations are in progress" in the remark section.)	
(2) 無操縦者航空機が運航される場合、有視界飛行方式により当該空域に入域する際は、ATC トランスポンダーの VFRコード (飛行高度 10,000 フィート未満は 1200、10,000 フィート以上は 1400) を発信するとともに、管制機関 (20,000 フィート以下の場合は三沢進入管制所、20,000 フィートを超える場合は札幌管制部) と無線電話により通信設定を行い、積極的に、自機の位置等運航情報を連絡し、また、管制機関によるレーダー業務 (レーダー・サービス) の提供を求める等により、無操縦者航空機の動向についてモニターを実施すること。		(2)During the unmanned aircraft operations, an aircraft mentioned above should squawk SSR code 1200 below 10,000 feet or 1400 at or above 10,000 feet, contact Misawa APP/ASR at or below 20,000 feet or SAPPORO-ACC above 20,000 feet, make position report proactively, and request radar services or take other suitable measures to monitor the movement of the unmanned aircraft.	
※ 三沢 ATIS 運用時間外に無操縦者航空機が運用される場合、臨時に ATIS 放送が実施される。		*Misawa ATIS temporarily opens and broadcasts the above information when the unmanned aircraft operations take place beyond Misawa ATIS service hours.	
※ 三沢進入管制所 (120.7MHz)		*Frequency for Misawa APP/ASR is 120.7MHz	
※ 札幌管制部 (124.5MHz)		*Frequency for SAPPORO-ACC is 124.5MHz	

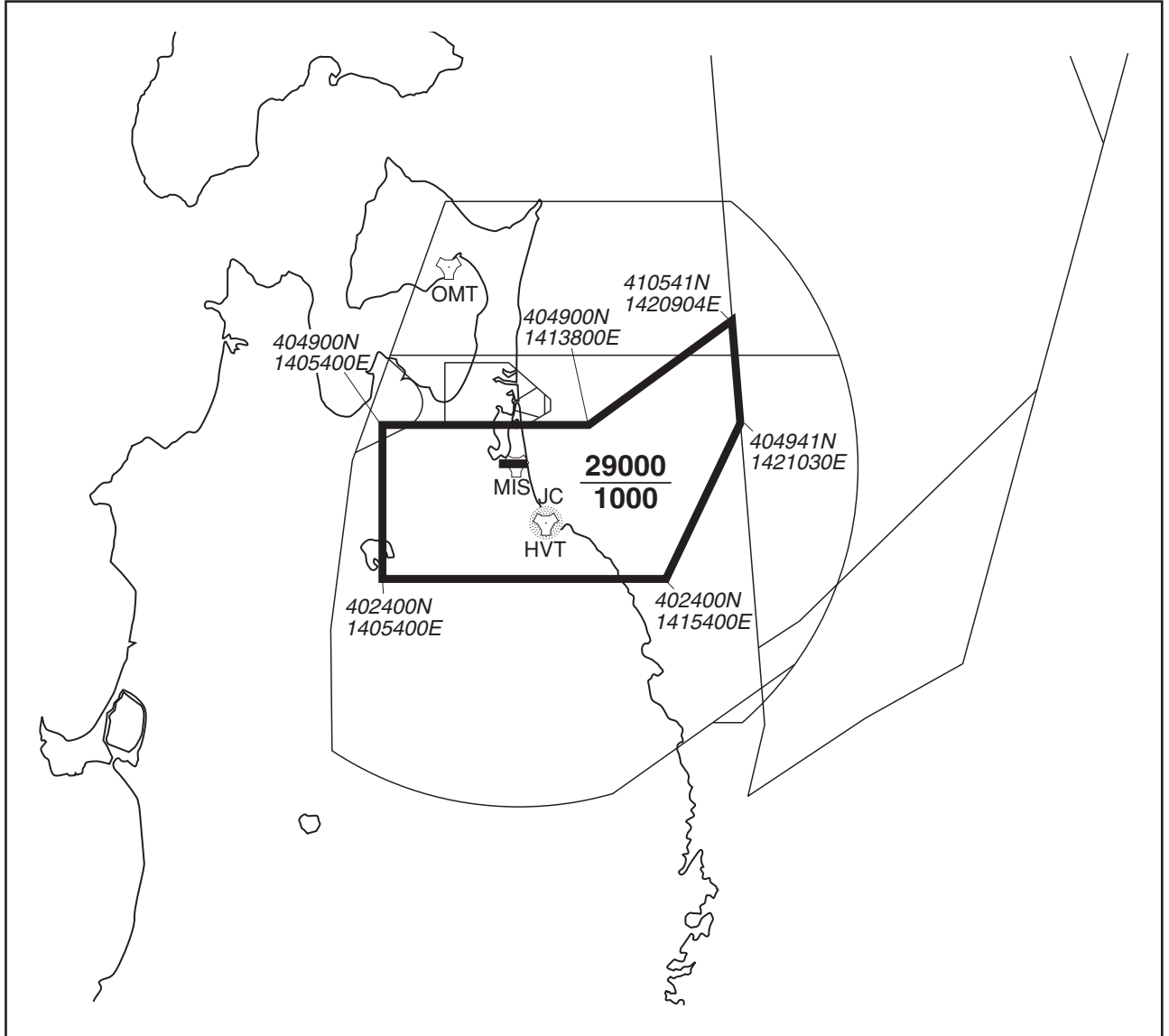

**RJSM AD 2.24 CHARTS RELATED TO AN AERODROME**

- Aerodrome/Heliport Chart
- Aircraft Parking/Docking Chart (for civil)
- Standard Departure Chart - Instrument
- Instrument Approach Chart (HI-ILS or LOC RWY28)
- Instrument Approach Chart (ILS or LOC RWY28)
- Instrument Approach Chart (HI-TACAN or VOR RWY28)
- Instrument Approach Chart (TACAN or VOR RWY28)
- Instrument Approach Chart (HI-ILS or LOC Z RWY10)
- Instrument Approach Chart (HI-TACAN or VOR RWY10)
- Other Chart (MVA CHART)

**INTENTIONALLY LEFT BLANK**



RJSM / MISAWA

AD CHART

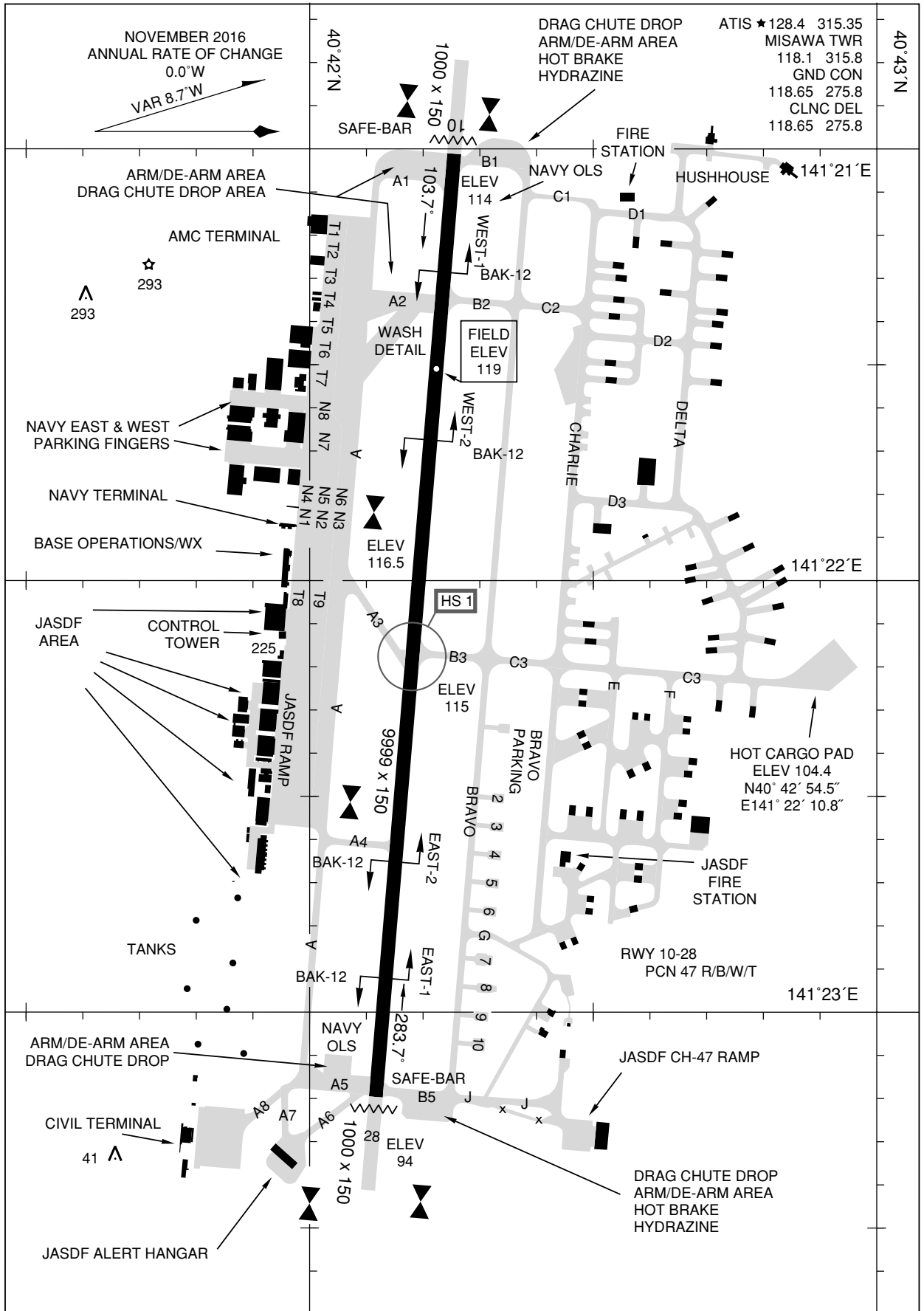

NOTE: REPRINTING DOD FLIP

RJSM / MISAWA

Minimum Vectoring Altitude CHART

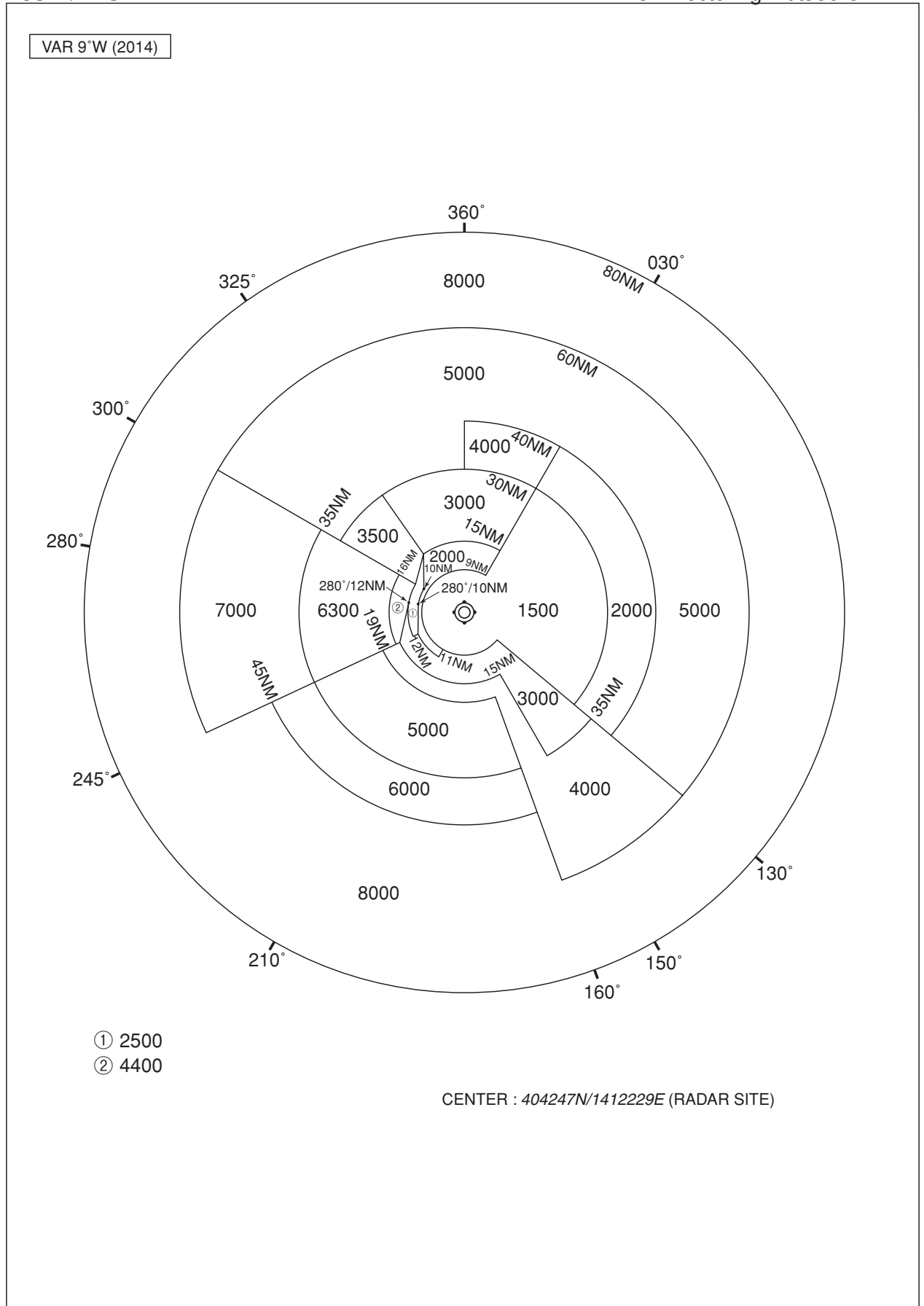

RJSM / MISAWA

Aircraft Parking / Docking Chart

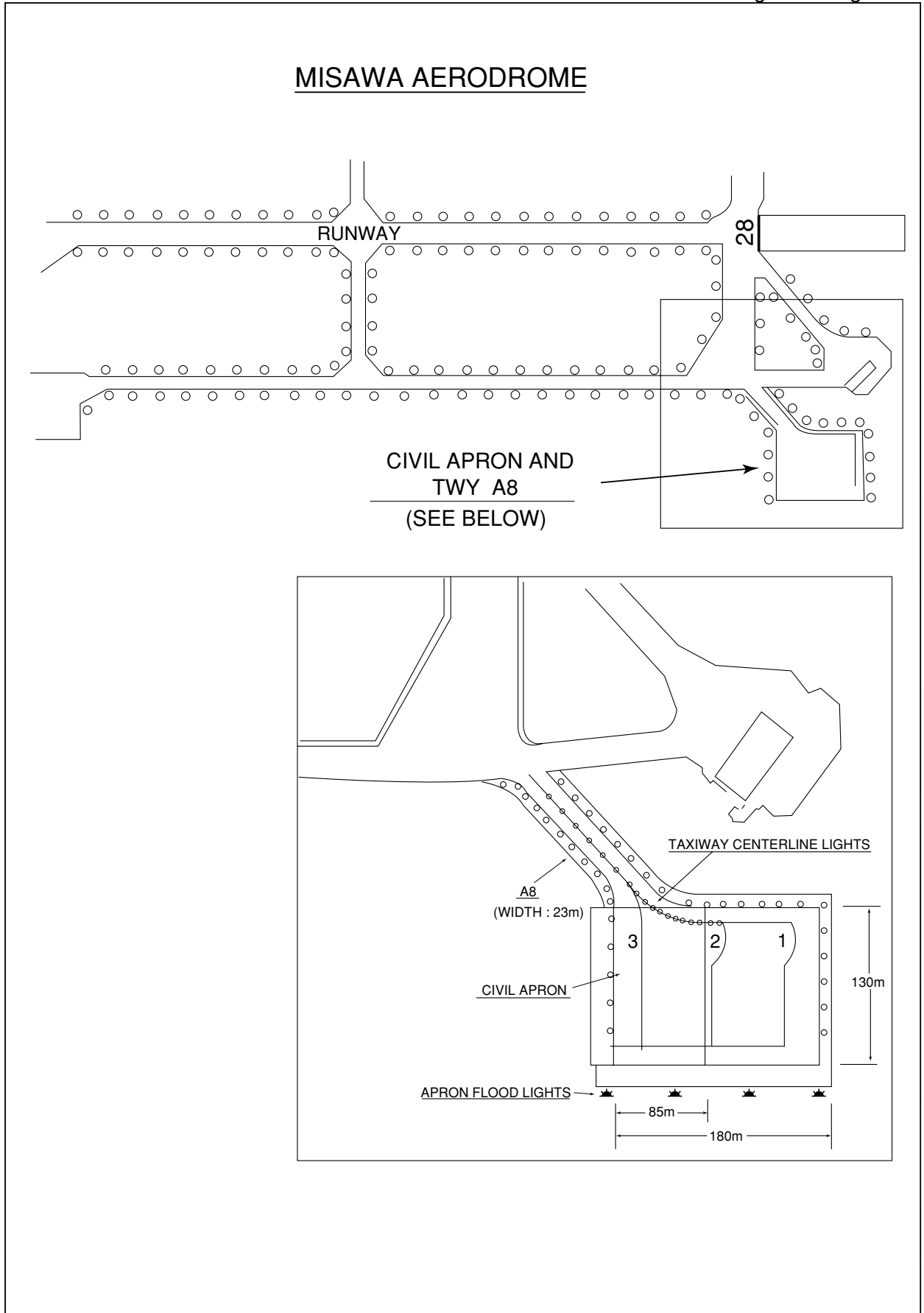

STANDARD DEPARTURE CHART - INSTRUMENT

RJSM / MISAWA

ENKAI TWO DEPARTURE

ATIS ★ 128.4 315.35  
 CLNC DEL  
 118.65 275.8  
 MISAWA TOWER  
 118.1 315.8  
 DEP CON  
 125.3 363.8  
 MISAWA APP CON  
 120.7 317.8

Rwy	Knots	60	120	180	240	300	360
10	V/V(fpm)	350	700	1050	1400	1750	2100

ATC Climb Rate to 3500

3802

MISAWA  
 115.4 MIS   
 Chan 101

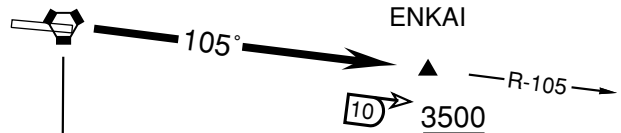

TA 14,000



DEPARTURE ROUTE DESCRIPTION

TAKE-OFF RWY 10: Climb on MIS VORTAC R-105 to ENKAI.  
 Cross ENKAI at or above 3500.

NOTE: REPRINTING DOD FLIP

STANDARD DEPARTURE CHART - INSTRUMENT

RJSM / MISAWA

KOSUI TWO DEPARTURE

ATIS ★ 128.4 315.35  
 CLNC DEL  
 118.65 275.8  
 MISAWA TOWER  
 118.1 315.8  
 DEP CON  
 125.3 363.8  
 MISAWA APP CON  
 120.7 317.8

Rwy	Knots	60	120	180	240	300	360
28	V/V(fpm)	406	812	1218	1624	2030	2436

ATC Climb Rate to 3600

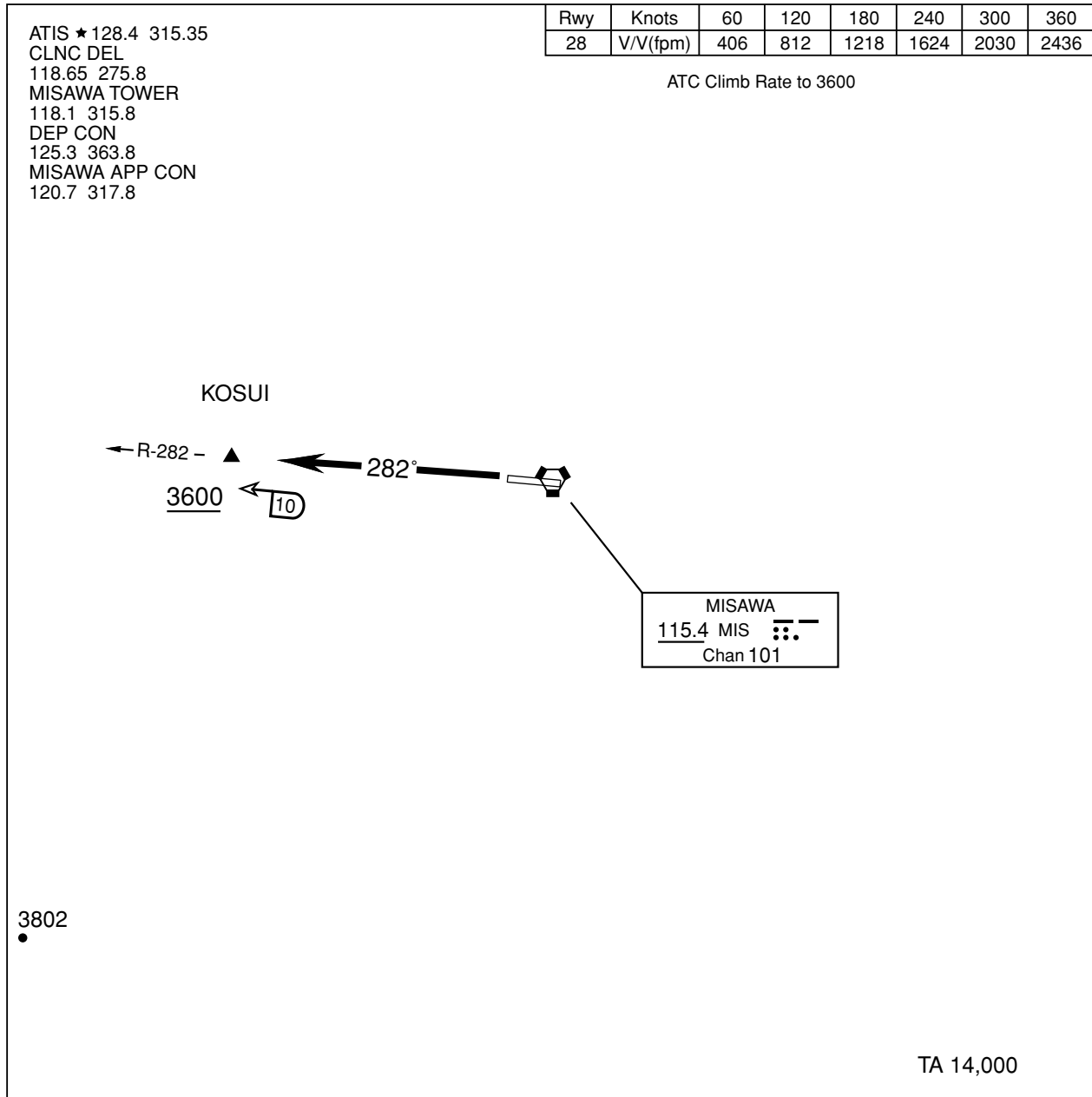

DEPARTURE ROUTE DESCRIPTION

TAKE-OFF RWY 28: Climb on MIS VORTAC R-282 to KOSUI.  
 Cross KOSUI at or above 3600.

NOTE: REPRINTING DOD FLIP

STANDARD DEPARTURE CHART - INSTRUMENT

RJSM / MISAWA

MISAWA SIX DEPARTURE

ATIS ★ 128.4 315.35  
CLNC DEL  
118.65 275.8  
MISAWA TOWER  
118.1 315.8  
DEP CON  
125.3 363.8  
MISAWA APP CON  
120.7 317.8

Rwy	Knots	60	120	180	240	300	360
*28 (a)(c)	V/V(fpm)	215	430	645	860	1075	1290
*28 (b)	V/V(fpm)	251	502	753	1004	1255	1506
†28 (d)	V/V(fpm)	221	442	663	884	1105	1326
†28 (e)	V/V(fpm)	313	626	939	1252	1565	1878
†10 (f)	V/V(fpm)	299	598	897	1196	1495	1794
†28 (f)	V/V(fpm)	336	672	1008	1344	1680	2016
†10 (g)	V/V(fpm)	216	432	648	864	1080	1296
†28 (g)	V/V(fpm)	218	436	645	872	1090	1308
†10 (h)	V/V(fpm)	256	512	768	1024	1280	1536
†28 (h)	V/V(fpm)	220	440	660	880	1100	1320

\* Minimum Climb Rate † ATC Climb Rate

- (a) OLSAE Transition to 5000
- (b) JYONA Transition to 600
- (c) SAMBO Transition to 4900
- (d) OLSAE Transition to 9000
- (e) JYONA Transition to 3500
- (f) SAMBO Transition to 13,000
- (g) HANAMAKI Transition to 10,000
- (h) MIYAKO Transition to 8000

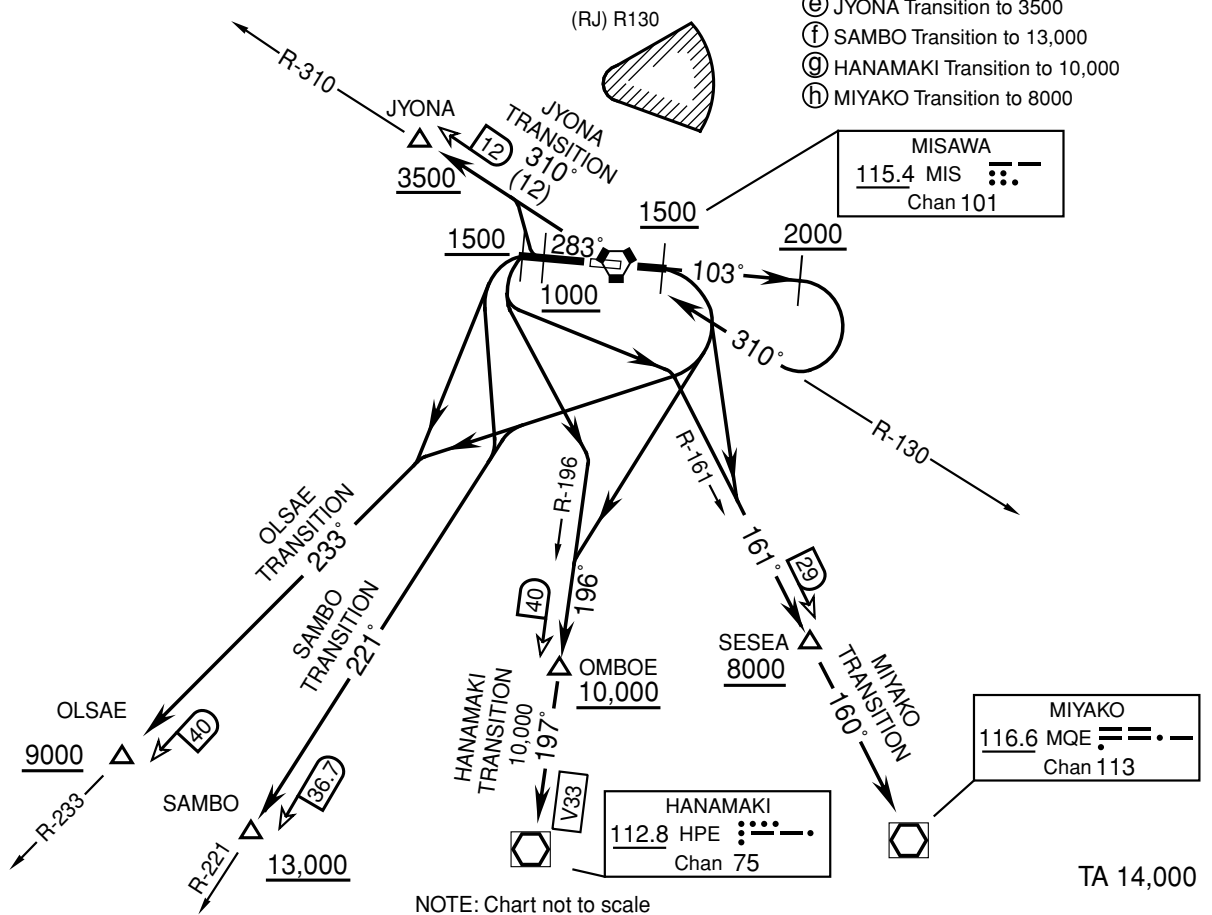

DEPARTURE ROUTE DESCRIPTION

TAKE-OFF RWY 10: Climb heading 103° to 1500, thence ....

TAKE-OFF RWY 28: Climb heading 283° to 1500 (1000 for JYONA TRANSITION), thence ....

(Continued on next page)

NOTE: REPRINTING DOD FLIP

## STANDARD DEPARTURE CHART - INSTRUMENT

RJSM / MISAWA

MISAWA SIX DEPARTURE

DEPARTURE ROUTE DESCRIPTION  
(Continued)HANAMAKI TRANSITION:

TAKE-OFF RWY 10: ...turn right to intercept MIS TACAN R-196 (HPE VOR/DME R-017) to HANAMAKI VOR/DME. Cross OMBOE at or above 10,000. Maintain ATC assigned altitude.

TAKE-OFF RWY 28: ...turn left to intercept MIS R-196 (HPE R-017) to HANAMAKI VOR/DME. Cross OMBOE at or above 10,000. Maintain ATC assigned altitude.

JYONA TRANSITION:

TAKE-OFF RWY 10: ...continue climb to 2000, then turn right and climb via MIS VORTAC to intercept MIS R-310 direct to JYONA. Cross JYONA at or above 3500. Maintain ATC assigned altitude.

TAKE-OFF RWY 28: ...then turn right to intercept MIS R-310 to JYONA. Cross JYONA at or above 3500. Maintain ATC assigned altitude.

MIYAKO TRANSITION:

TAKE-OFF RWY 10: ...turn right to intercept MIS R-161 (MQE VOR/DME R-340) to MIYAKO VOR/DME. Cross the SESEA at or above 8000. Maintain ATC assigned altitude.

TAKE-OFF RWY 28: ...turn left to intercept MIS R-161 (MQE R-340) to MIYAKO VOR/DME. Cross the SESEA at or above 8000. Maintain ATC assigned altitude.

OLSAE TRANSITION:

TAKE-OFF RWY 10: ...turn right to intercept MIS R-233 to OLSAE (MIS R-233/40 DME). Cross OLSAE at or above 9000. Maintain ATC assigned altitude.

TAKE-OFF RWY 28: ...turn left to intercept MIS R-233 to OLSAE (MIS R-233/40 DME). Cross OLSAE at or above 9000. Maintain ATC assigned altitude.

SAMBO TRANSITION:

TAKE-OFF RWY 10: ...turn right to intercept MIS R-221 to SAMBO (MIS R-221/36.7 DME). Cross SAMBO at or above 13,000. Maintain ATC assigned altitude.

TAKE-OFF RWY 28: ...turn left to intercept MIS R-221 to SAMBO (MIS R-221/36.7 DME). Cross SAMBO at or above 13,000. Maintain ATC assigned altitude.

NOTE: REPRINTING DOD FLIP

STANDARD DEPARTURE CHART - INSTRUMENT

RJSM / MISAWA

REIWA ONE DEPARTURE

ATIS ★  
128.4 315.35  
CLNC DEL  
118.65 275.8  
MISAWA TOWER  
118.1 315.8  
DEP CON  
125.3 363.8  
MISAWA APP CON  
120.7 317.8

Rwy	Knots	60	120	180	240	300	360
10	V/V(fpm)	289	578	867	1156	1445	1734
28	V/V(fpm)	249	498	747	996	1245	1494

ATC Climb Rate to 10,000

EFFECTIVE BY NOTAM

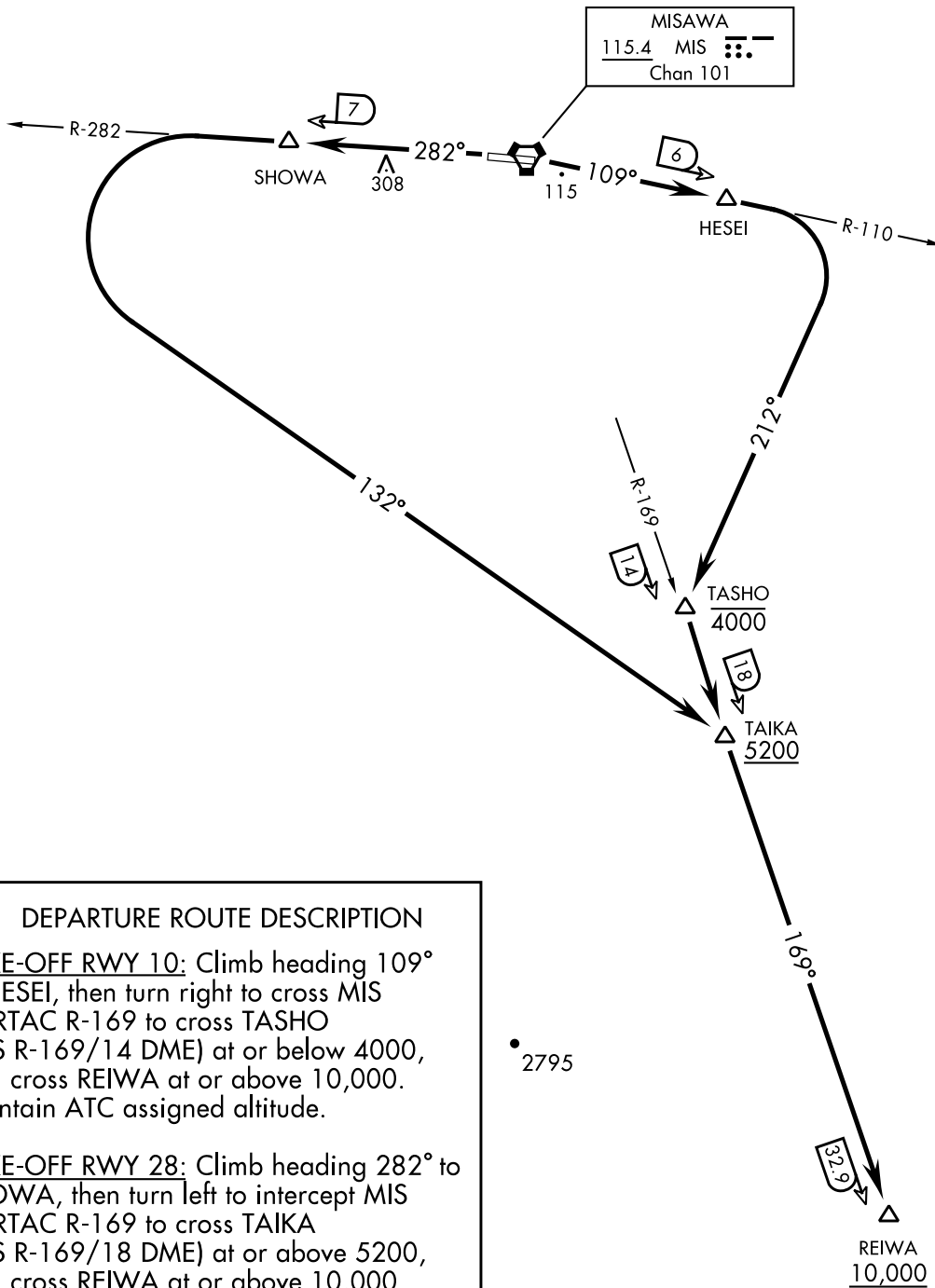

▼ DEPARTURE ROUTE DESCRIPTION

TAKE-OFF RWY 10: Climb heading 109° to HESEI, then turn right to cross MIS VORTAC R-169 to cross TASHO (MIS R-169/14 DME) at or below 4000, then cross REIWA at or above 10,000. Maintain ATC assigned altitude.

TAKE-OFF RWY 28: Climb heading 282° to SHOWA, then turn left to intercept MIS VORTAC R-169 to cross TAIKA (MIS R-169/18 DME) at or above 5200, then cross REIWA at or above 10,000. Maintain ATC assigned altitude.

CHANGE : New PROC

Tlv FL140  
TA 14,000

NOTE: REPRINTING DOD FLIP



**INTENTIONALLY LEFT BLANK**

INSTRUMENT APPROACH CHART

RJSM / MISAWA

LOC I-MIS <b>109.7</b>	APCH CRS <b>283°</b>	Rwy ldg <b>9999</b> TDZE <b>109</b> Arpt Elev <b>119</b>	HI-ILS or LOC RWY28		
▼ * When ALS inop, increase RVR to 40 and vis to 3/4 mile. ** When ALS inop, increase CAT AB RVR to 55 and vis to 1 mile, CAT CDE RVR to 60 and vis to 1 1/2 miles. *** Circling not authorized S of Rwy 10-28.		ALS F-1 	† MISSED APPROACH: Climb to 7000 on MIS VORTAC R-280 to KISSA, then climbing left turn direct SHOJU and hold. Continue climb in holding to 7000.		
ATIS ★ <b>128.4 315.35</b>	MISAWA APP CON <b>120.7 317.8</b>	MISAWA TOWER <b>118.1 315.8</b>	GND CON <b>118.65 275.8</b>	CLNC DEL <b>118.65 275.8</b>	ASR/PAR

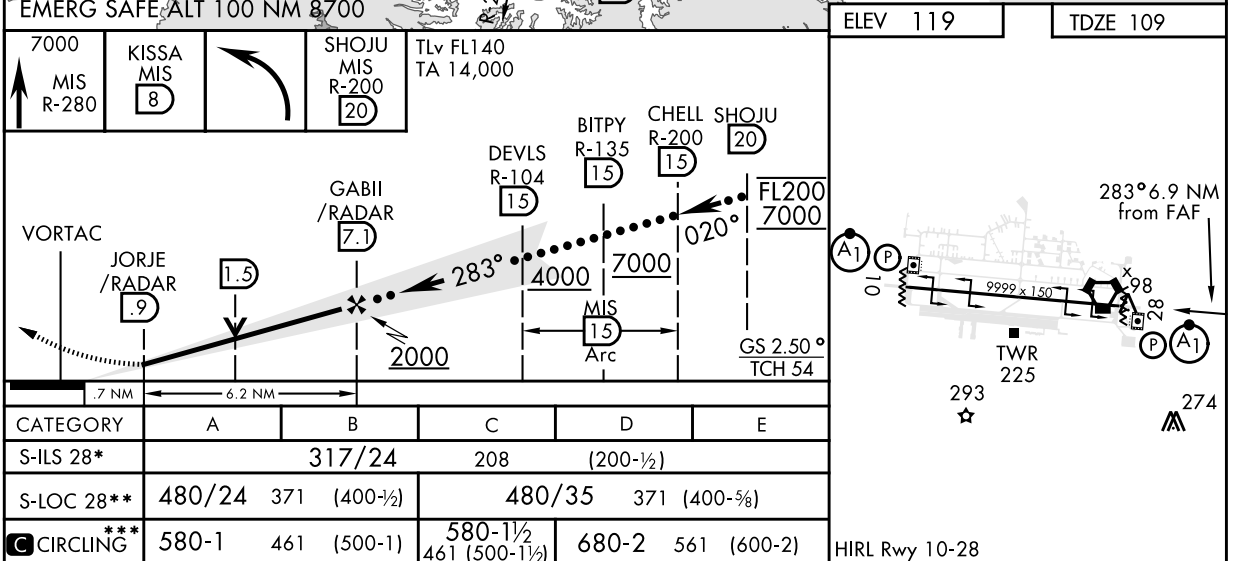
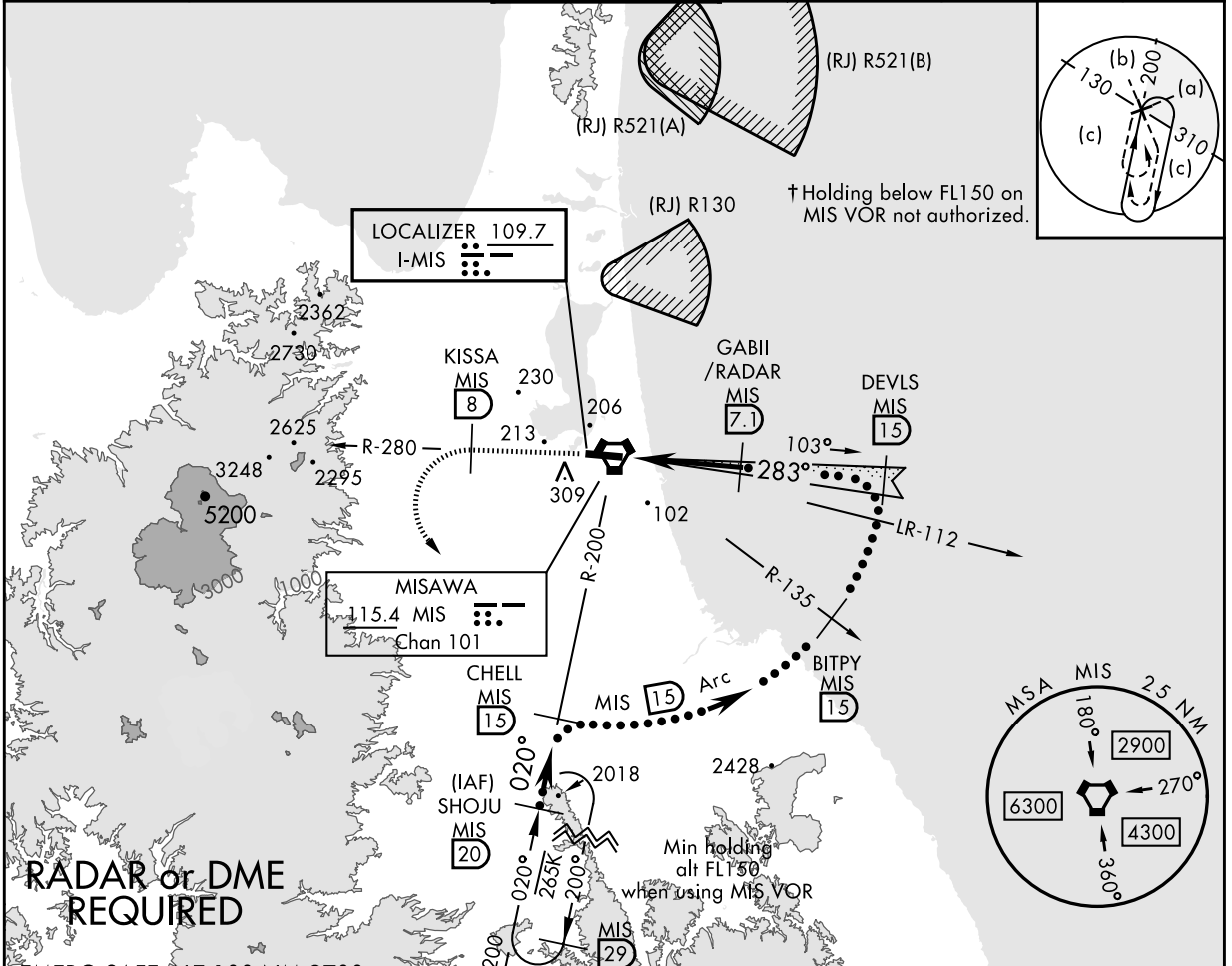

NOTE: REPRINTING DOD FLIP

INSTRUMENT APPROACH CHART

RJSM / MISAWA

LOC I-MIS <b>109.7</b>	APCH CRS <b>283°</b>	Rwy ldg <b>9999</b> TDZE <b>109</b> Arprt Elev <b>119</b>	ILS or LOC RWY28		
▼ * When ALS inop, increase RVR to 40 and vis to 3/4 mile. ** When ALS inop, increase CAT AB RVR to 55 and vis to 1 mile, CAT CDE RVR to 60 and vis to 1 1/8 miles. *** Circling not authorized S of Rwy 10-28.		ALSF-1 	† MISSED APPROACH: Climb to 7000 on MIS VORTAC R-280 to KISSA, then climbing left turn direct SHOJU and hold. Continue climb in holding to 7000.		
ATIS ★ <b>128.4 315.35</b>	MISAWA APP CON <b>120.7 317.8</b>	MISAWA TOWER <b>118.1 315.8</b>	GND CON <b>118.65 275.8</b>	CLNC DEL <b>118.65 275.8</b>	ASR/PAR

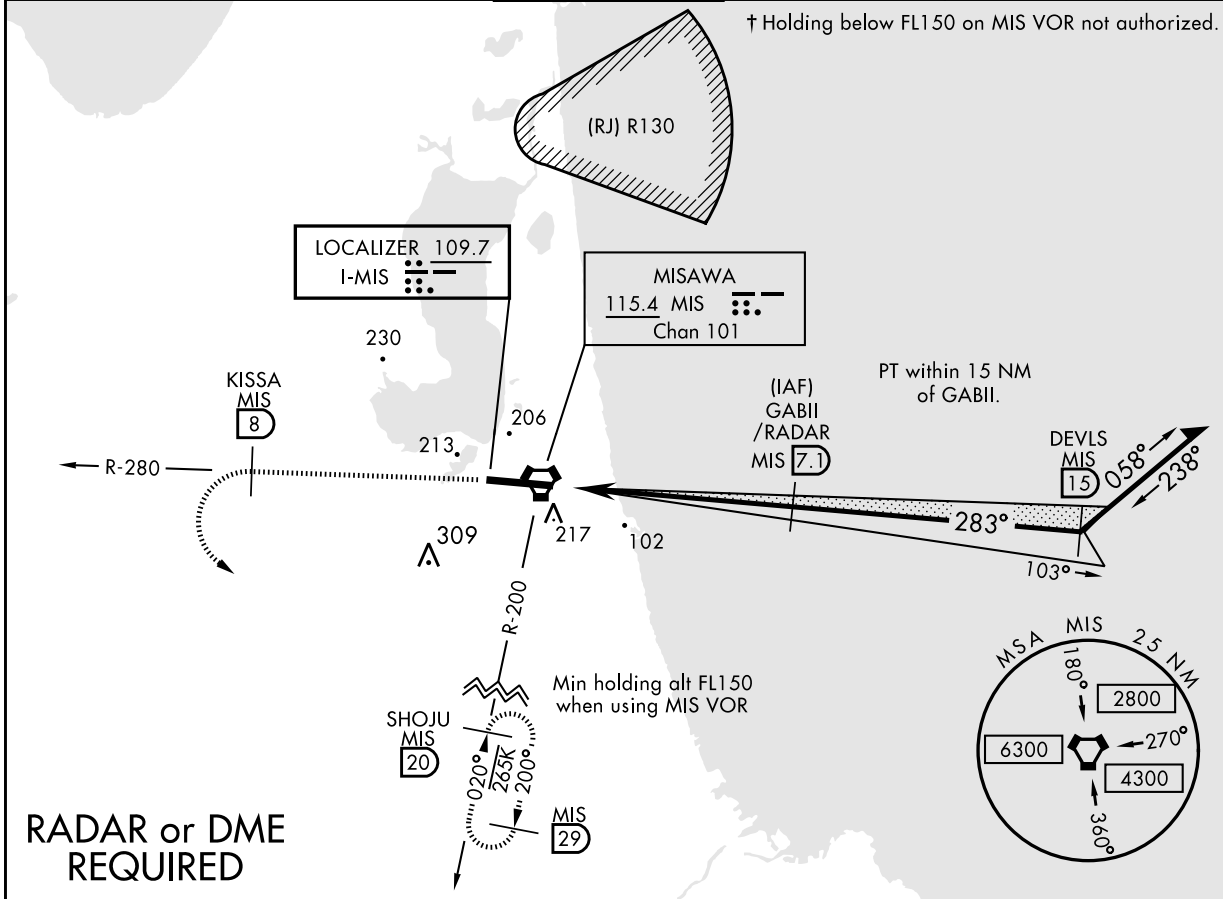

ELEV 119	TDZE 109
----------	----------

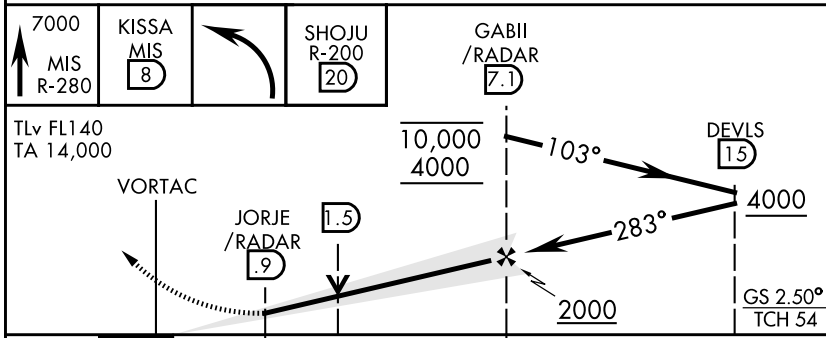

CATEGORY	A	B	C	D	E
S-ILS 28*	317/24		208	(200-1/2)	
S-LOC 28**	480/24 371 (400-1/2)		480/35	371	(400-5/8)
CIRCLING ***	580-1 461 (500-1)		580-1 1/2 461 (500-1 1/2)	680-2 561 (600-2)	

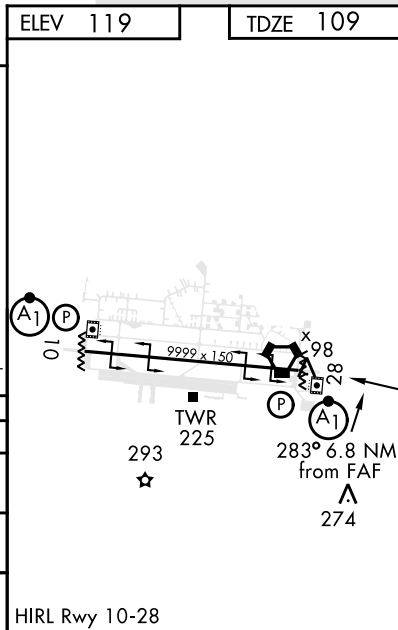

CHANGE : Update

NOTE: REPRINTING DOD FLIP

INSTRUMENT APPROACH CHART

RJSM / MISAWA

VORTAC MIS <b>115.4</b> Chan <b>101</b>	APCH CRS <b>290°</b>	Rwy Idg <b>9999</b> TDZE <b>109</b> Arpt Elev <b>119</b>	HI-TACAN or VOR RWY28
---	-------------------------	--	-----------------------

▼ \* When ALS inop, increase CAT AB RVR to 55 and vis to 1 mile, CAT CDE vis to 1½ miles.  
 \*\* Circling S of Rwy 10-28 not authorized.



MISSED APPROACH: Climb to 7000 on MIS VORTAC R-280 to KISSA, then climbing left turn direct SHOJU and hold. Continue climb in holding to 7000.

ATIS ★ <b>128.4 315.35</b>	MISAWA APP CON <b>120.7 317.8</b>	MISAWA TOWER <b>118.1 315.8</b>	GND CON <b>118.65 275.8</b>	CLNC DEL <b>118.65 275.8</b>	ASR/PAR
-------------------------------	--------------------------------------	------------------------------------	--------------------------------	---------------------------------	---------

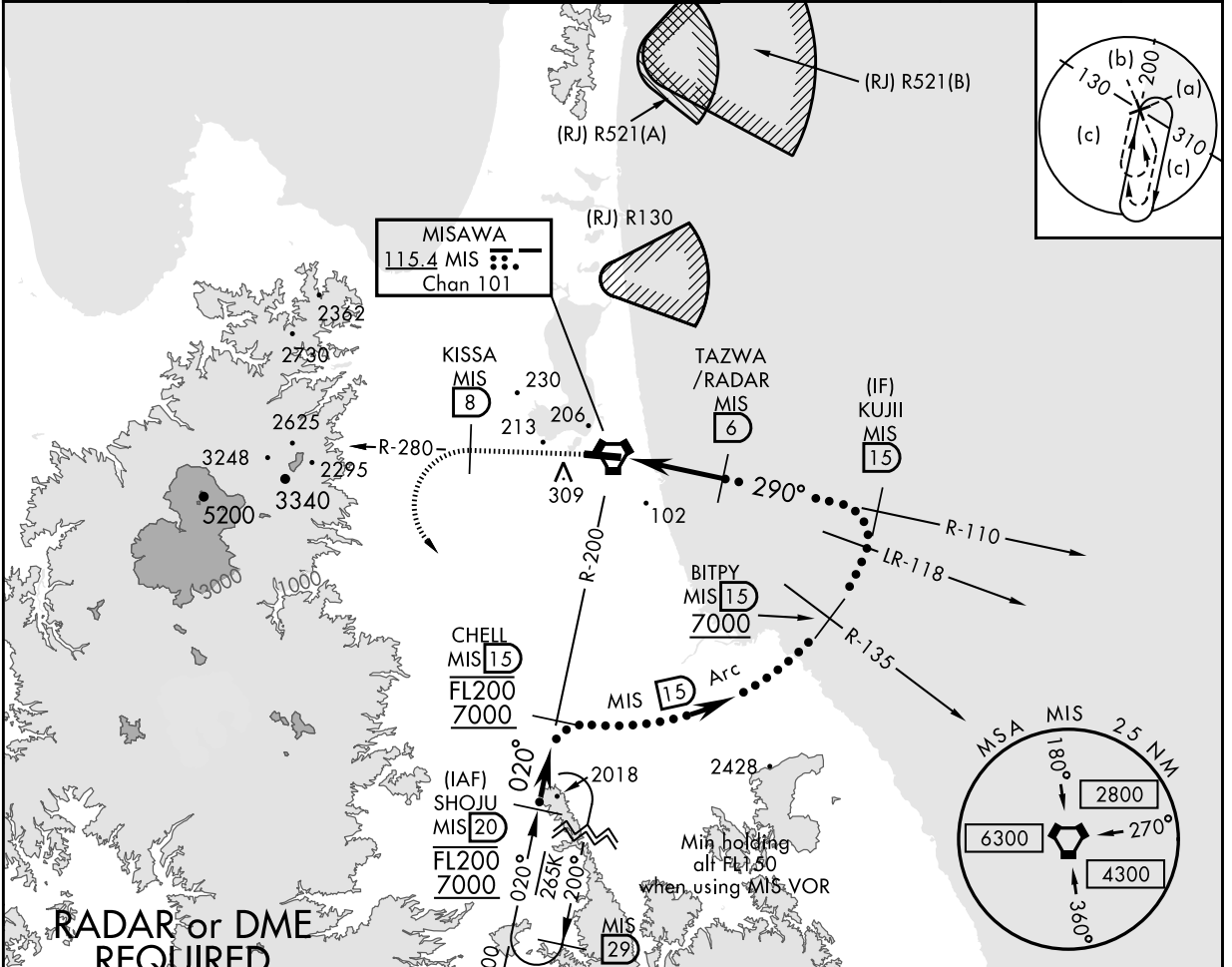

ELEV 119	TDZE 109
----------	----------

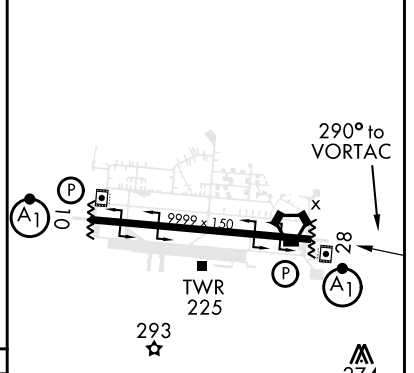
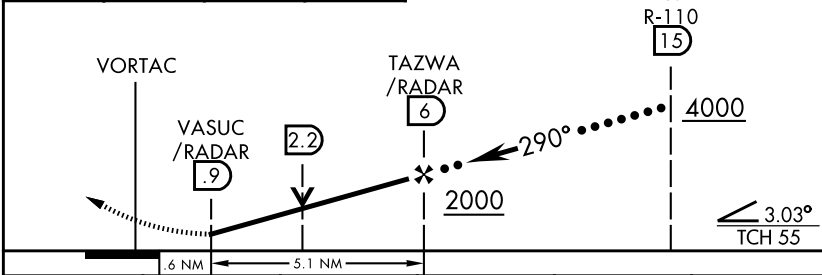
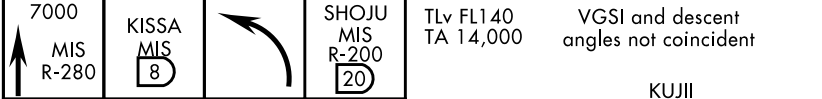

CHANGE : Update

CATEGORY	A	B	C	D	E
S-28*	660/24 551 (600-½)		660/60	551	(600-1½)
<b>C</b> CIRCLING**	660-1 541 (600-1)		660-1½ 541 (600-1½)	680-2	561 (600-2)

HIRL Rwy 10-28

NOTE: REPRINTING DOD FLIP

INSTRUMENT APPROACH CHART

RJSM / MISAWA

VORTAC MIS <b>115.4</b> Chan <b>101</b>	APCH CRS <b>290°</b>	Rwy ldg <b>9999</b> TDZE <b>109</b> Arprt Elev <b>119</b>
---	-------------------------	---

TACAN or VOR RWY28

▼ \* When ALS inop, increase CAT AB RVR to 55 and vis to 1 mile, CAT CDE vis to 1½ miles.  
\*\* Circling S of Rwy 10-28 not authorized.



MISSED APPROACH: Climb to 7000 on MIS VORTAC R-280 to KISSA, then climbing left direct SHOJU and hold. Continue climb in holding to 7000.

ATIS ★ <b>128.4 315.35</b>	MISAWA APP CON <b>120.7 317.8</b>	MISAWA TOWER <b>118.1 315.8</b>	GND CON <b>118.65 275.8</b>	CLNC DEL <b>118.65 275.8</b>	ASR/PAR
-------------------------------	--------------------------------------	------------------------------------	--------------------------------	---------------------------------	---------

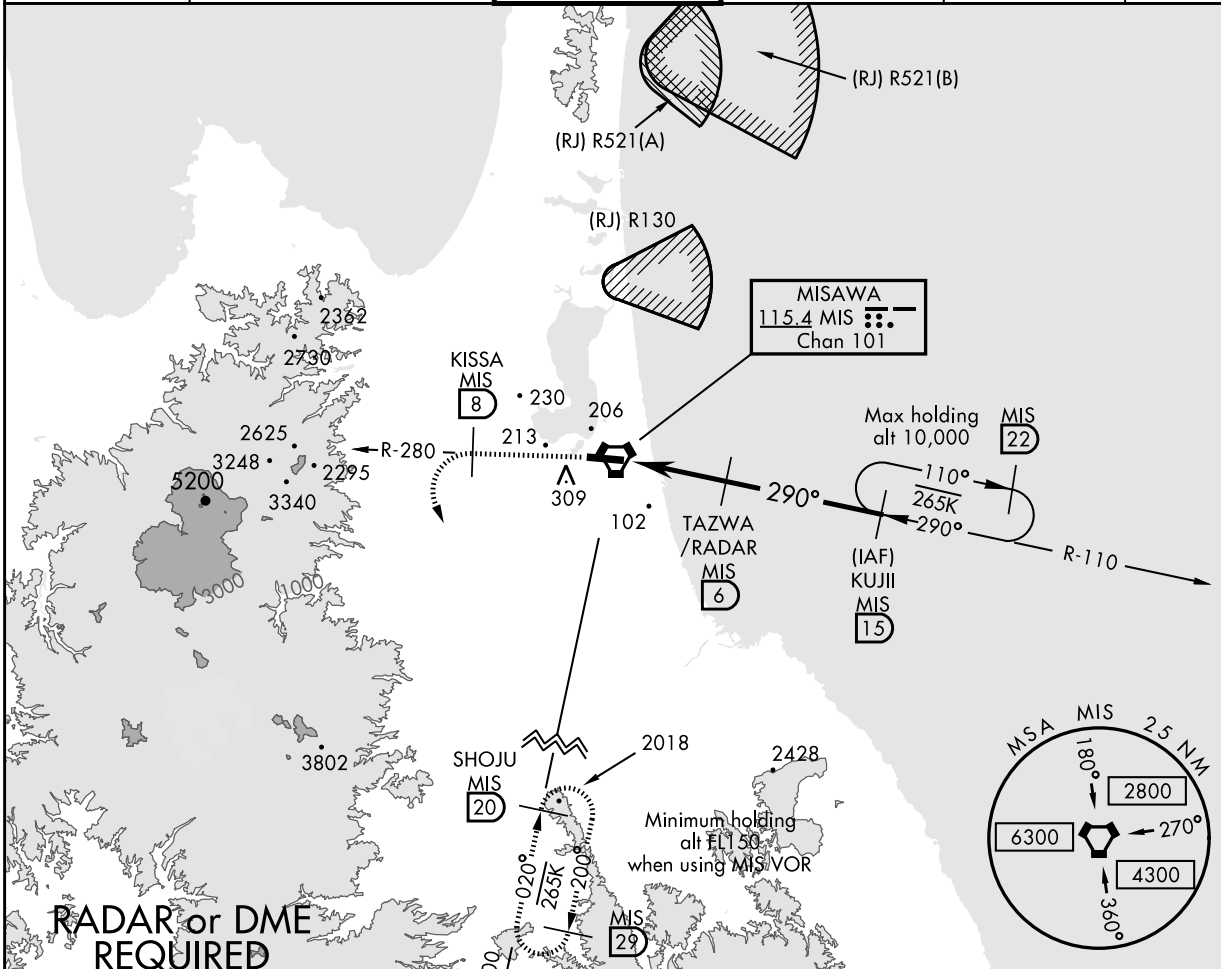

**RADAR or DME REQUIRED**

EMERG SAFE ALT 100 NM 8700

ELEV 119	TDZE 109
----------	----------

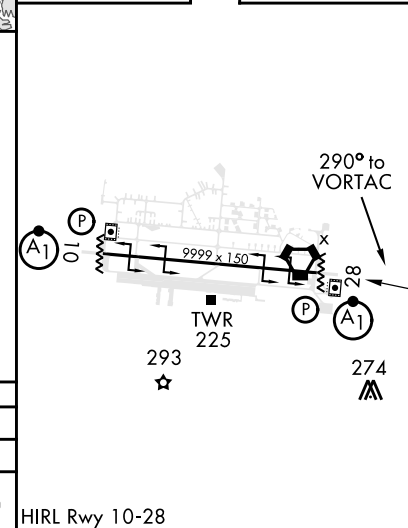
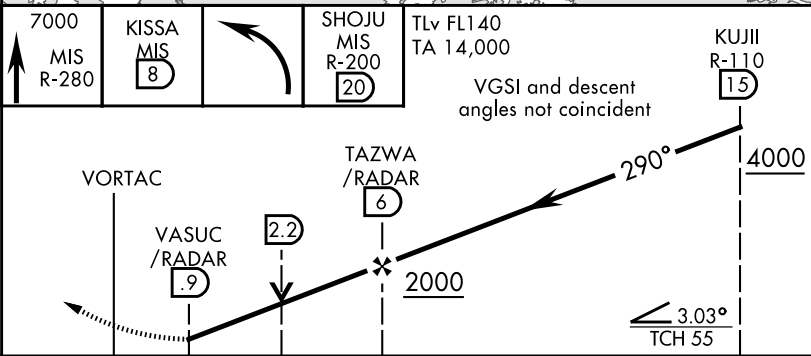

CHANGE : Update

CATEGORY	A	B	C	D	E
S-28*	660/24 551 (600-½)		660/60 551 (600-1½)		
☐ CIRCLING**	660-1 541 (600-1)		660-1½ 541(600-1½)	680-2 561 (600-2)	

HIRL Rwy 10-28

NOTE: REPRINTING DOD FLIP

INSTRUMENT APPROACH CHART

RJSM / MISAWA

LOC I-MAS <b>109.7</b>	APCH CRS <b>103°</b>	Rwy Idg <b>9999</b>	TDZE <b>119</b>	HI-ILS or LOC Z RWY10	
<p><b>▼</b> *When ALS inop, increase RVR to 40 and vis to 3/4 mile. **When ALS inop, increase CAT AB RVR to 55 and vis to 1 mile, CAT CDE vis to 1 3/8 miles. ***Circling not authorized south of Rwy 10-28.</p>		ALSF-1 		MISSED APPROACH: Climb to 4000 on MIS VORTAC R-106 to STICK and hold. Continue climb in holding to 4000.	
ATIS ★ <b>128.4 315.35</b>	MISAWA APP CON <b>120.7 317.8</b>	MISAWA TOWER <b>118.1 315.8</b>	GND CON <b>118.65 275.8</b>	CLNC DEL <b>118.65 275.8</b>	ASR/PAR

CAUTION: Localizer unusable beyond 14 NM.

Auto coupled approaches are not authorized for B-747/767/777, L-1011, DC-10, A-300, B-1, KC-10, E-4, C-5, and VC-25 type aircraft below 319' MSL.

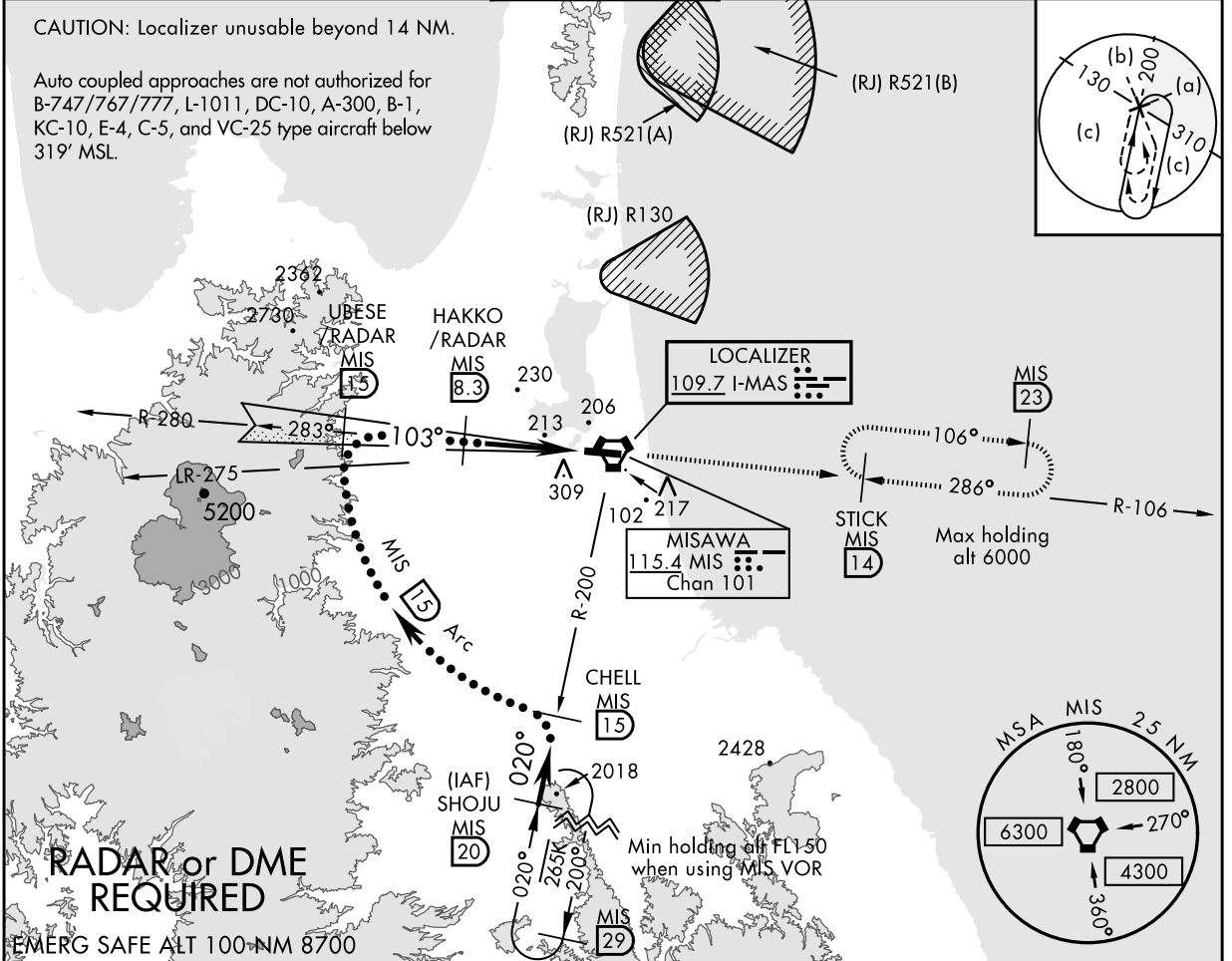

**RADAR or DME REQUIRED**

EMERG SAFE ALT 100-NM 8700

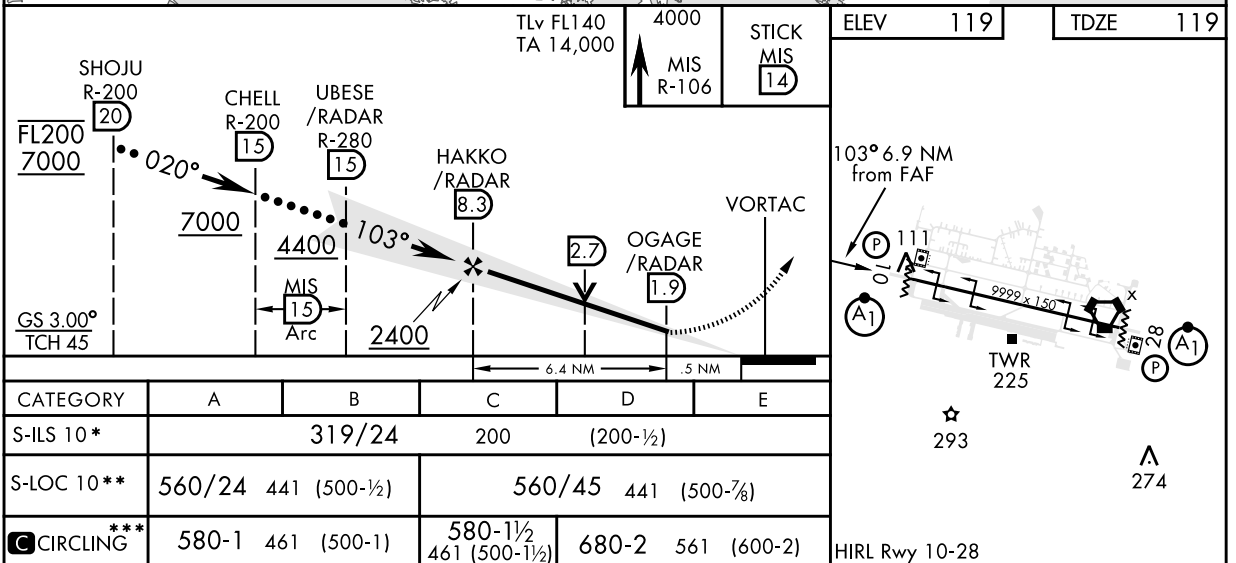

NOTE: REPRINTING DOD FLIP

INSTRUMENT APPROACH CHART

RJSM / MISAWA

VORTAC MIS <b>115.4</b> Chan <b>101</b>	APCH CRS <b>101°</b>	Rwy Idg <b>9999</b> TDZE <b>119</b> Arpt Elev <b>119</b>
---	-------------------------	--

HI-TACAN or VOR RWY10

▼ \* When ALS inop, increase RVR CAT AB to 55 and vis to 1 mile, CAT CDE vis to 1½ miles.  
\*\* Circling S of Rwy 10-28 not authorized.



MISSED APPROACH: Climb to 4000 on MIS VORTAC R-106 to STICK and hold. Continue climb in holding to 4000.

ATIS ★ <b>128.4 315.35</b>	MISAWA APP CON <b>120.7 317.8</b>	MISAWA TOWER <b>118.1 315.8</b>	GND CON <b>118.65 275.8</b>	CLNC DEL <b>118.65 275.8</b>	ASR/PAR
-------------------------------	--------------------------------------	------------------------------------	--------------------------------	---------------------------------	---------

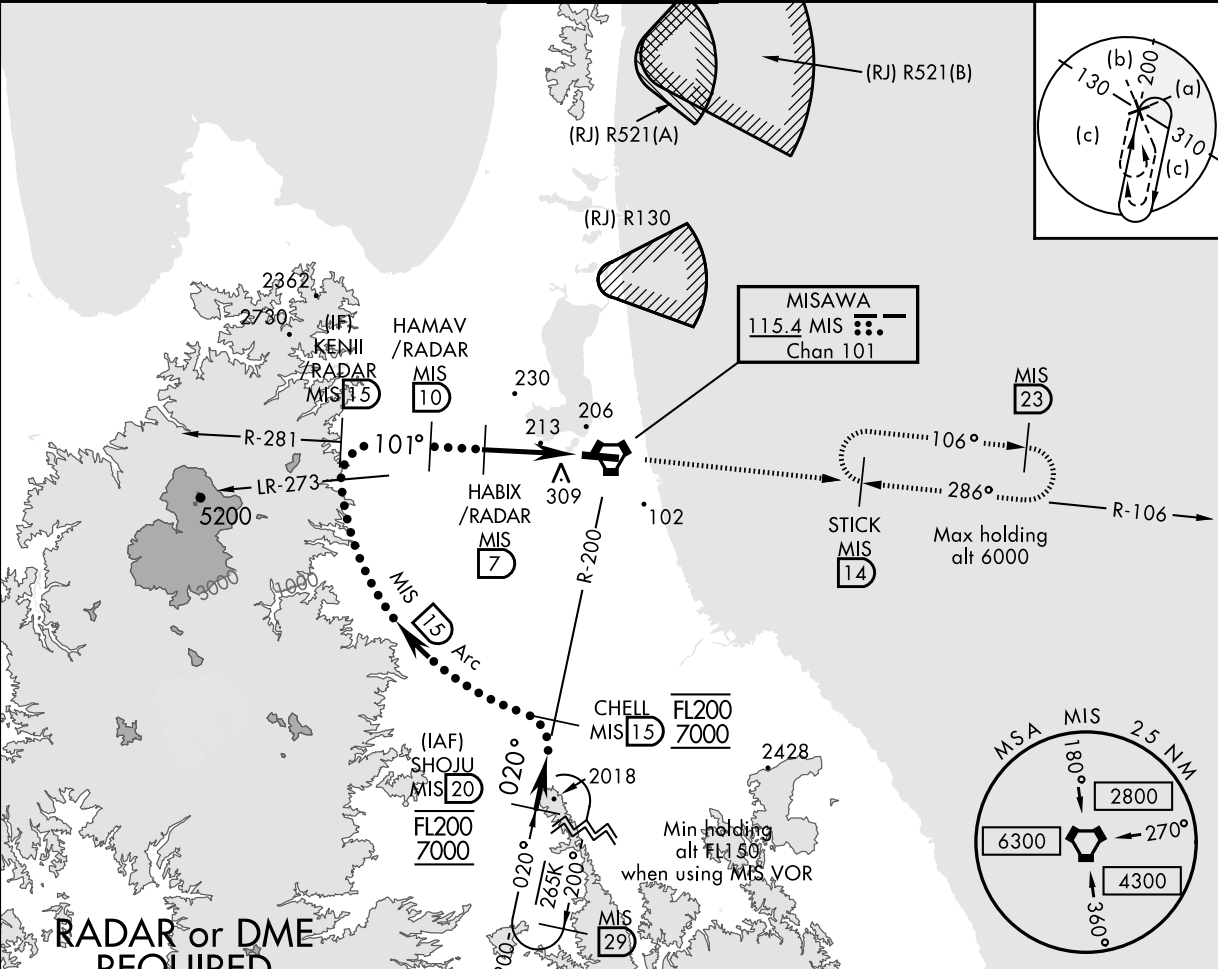

**RADAR or DME REQUIRED**  
EMERG SAFE ALT 100 NM 8700

ELEV 119	TDZE 119
----------	----------

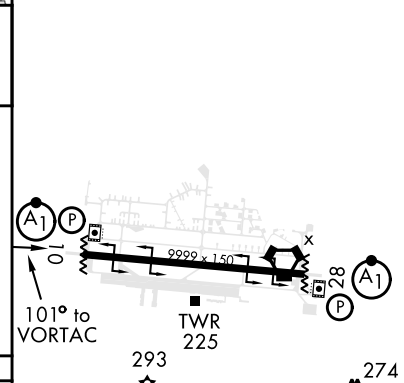
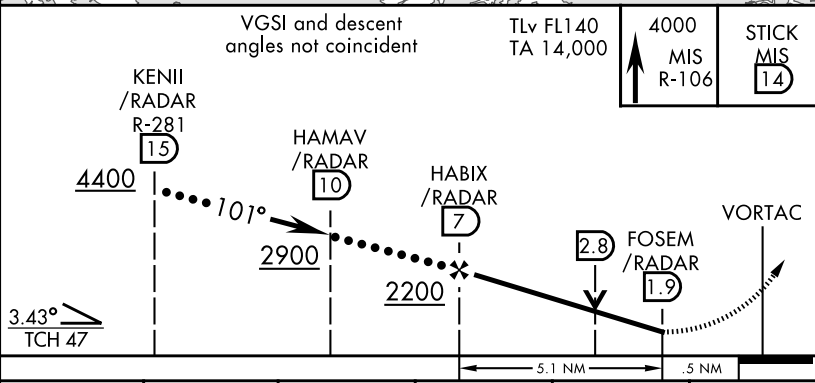

CHANGE : Update

CATEGORY	A	B	C	D	E
S-10*	620/24 501 (600-½)		620/55	501 (600-1)	
CIRCLING**	620-1 501 (600-1)		620-1½ 501(600-1½)	680-2 561 (600-2)	

HIRL Rwy 10-28

NOTE: REPRINTING DOD FLIP

## Airspace for the advisory service concerning low level wind shear

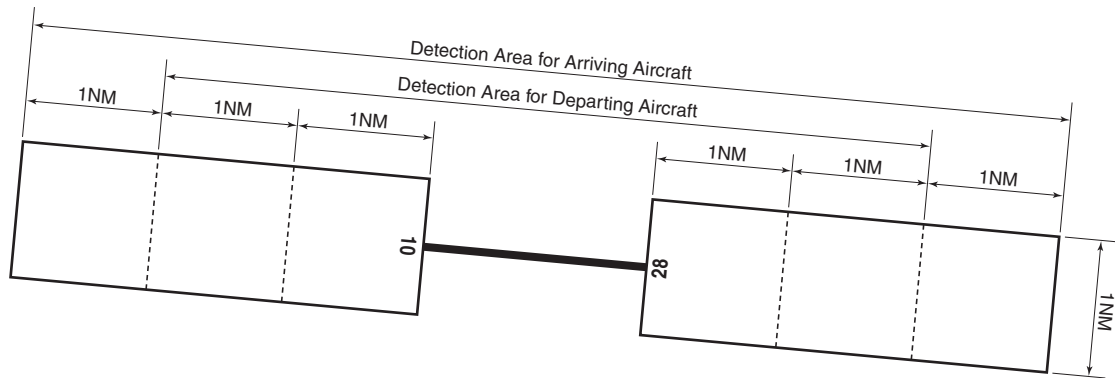

UPPER LIMIT: 1600ft above FIELD ELEV LEVEL

LOWER LIMIT: FIELD ELEV LEVEL



三沢進入管制区  
Misawa Approach Control Area

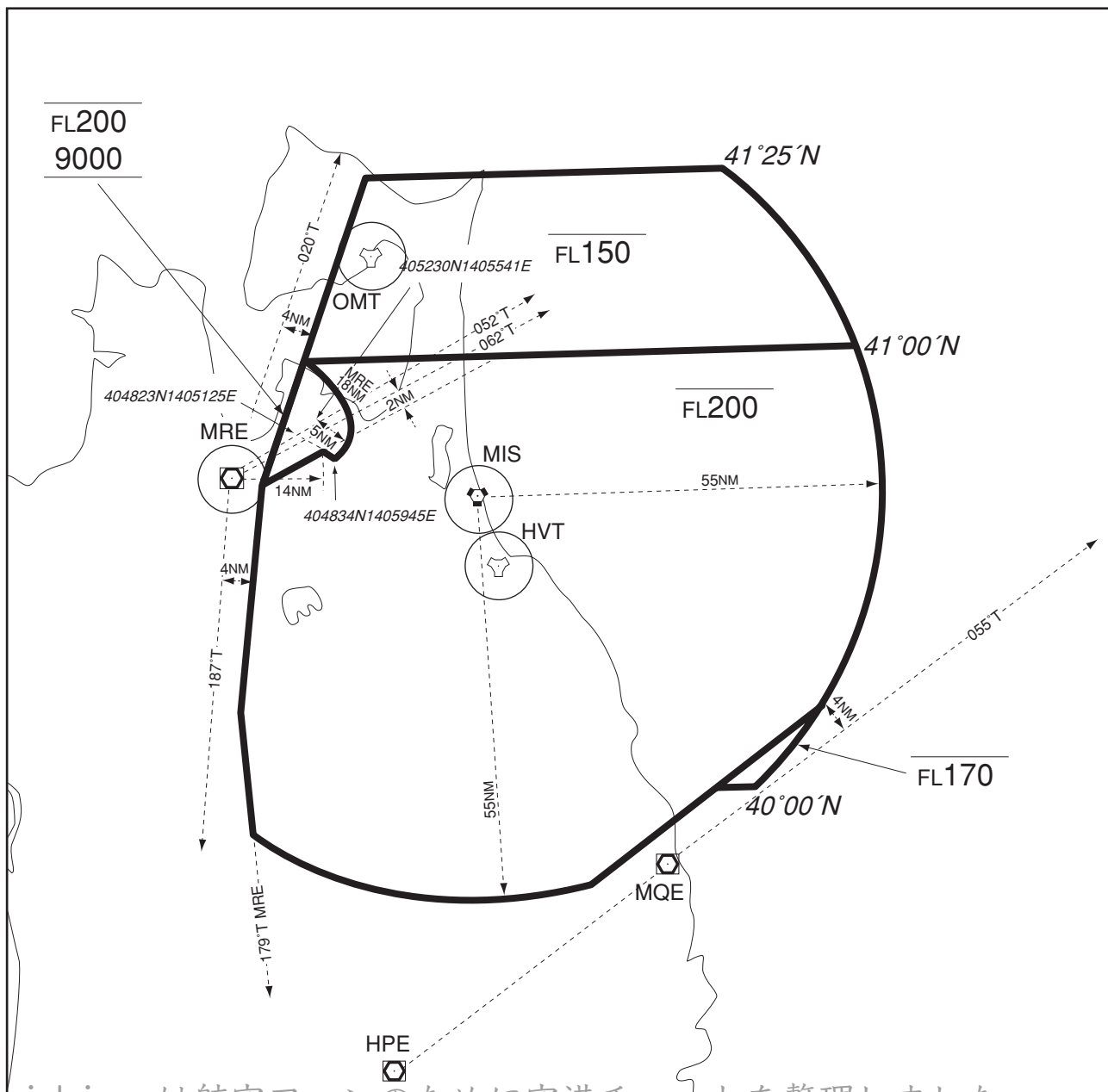

三沢特別管制区  
Misawa Positive Control Area

NAME	LATERAL LIMITS	UPPER LIMIT (AMSL)	UNIT PROVIDING SERVICE	REMARKS
		LOWER LIMIT (AMSL) M(ft)		
1	2	3	4	5
三沢 Misawa	下記に示される区域 The area shown below (1) 三沢第一特別管制区 Misawa NR 1 Positive Control Air Space  (2) 三沢第二特別管制区 Misawa NR 2 Positive Control Air Space		札幌ACC Sapporo ACC 124.5 MHz 303.8 MHz  三沢アプローチ Misawa APP RADAR  Primary 120.7 MHz 317.8 MHz  Secondary 261.2MHz	当該空域を飛行しようとする VFR機は、札幌ACCに連絡し、 飛行の許可を求めること。 VFR aircraft operating which will fly in the airspace above should contact Sapporo ACC and obtain the permission.  当該空域を飛行しようとする VFR機は、三沢アプローチ又 はレーダーに連絡し、飛行の 許可を求めること。 VFR aircraft operating which will fly in the airspace above should contact Misawa APP/RADAR and obtain the permission.

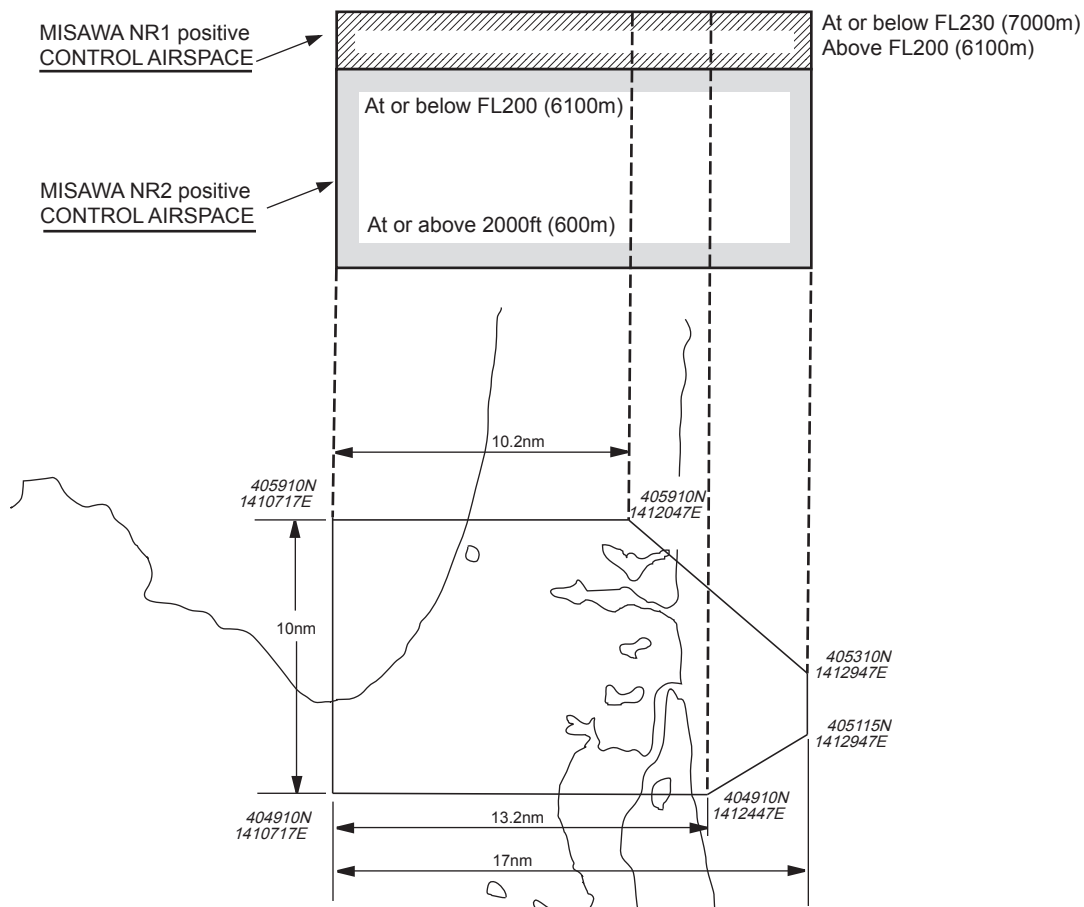

# 三沢ターミナルコントロールエリア Misawa Terminal Control Area

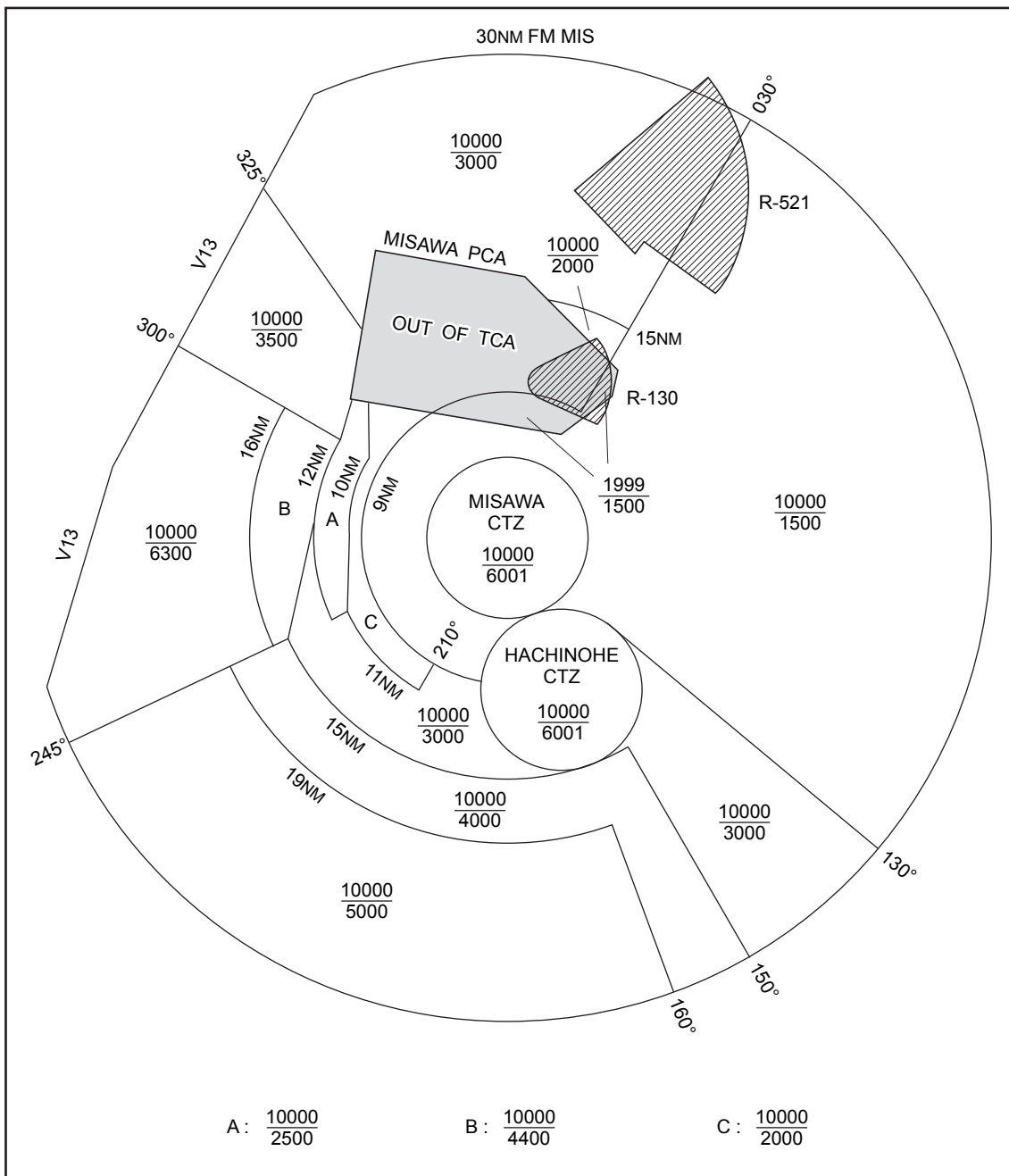

	<u>RWY</u>	<u>GS/TCH/RPI</u>	<u>CAT</u>	<u>DH/ MDA-VIS</u>	<u>HAT/HATH HAA</u>	<u>CEIL-VIS</u>
PAR ②	28 ④	3°/-/-	ABCDE	<b>209/18</b>	100	(100-1/4)
	10 ⑤	3°/-/-	ABCDE	<b>219/24</b>	100	(100-1/4)
ASR ②	10 ⑥		ABCDE	<b>480/40</b>	371	(400-3/4)
	28 ⑦		ABC	<b>540/40</b>	431	(500-3/4)
			DE	<b>540/50</b>	431	(500-1)
CIR ③	10-28		A	<b>540-1 1/4</b>	421	(500-1 1/4)
			B	<b>580-1 1/4</b>	461	(500-1 1/4)
			C	<b>580-1 1/2</b>	461	(500-1 1/2)
			DE	<b>680-2</b>	561	(600-2)

① a. LOST COMMUNICATIONS: If no transmissions are received for more than 30 seconds for Rwy 10 (1 minute for Rwy 28) during radar vectors to final, or for more than 5 seconds/15 seconds once established on PAR/ASR final approach, the pilot shall maintain VMC and attempt to contact Misawa Tower. If unable to maintain VMC, the pilot shall proceed to SHOJU IAF for the runway of departure, at last assigned alt or 9000, whichever is higher, and execute instrument approach or previously coordinated instruction.

① b. If com is lost on westerly hdg on downwind leg of radar apch to Rwy 10, do not exceed 10.7 mile fix of MISAWA VORTAC. CAUTION: Possible interference on freq 270.8 from Chitose. ② MP 2300-0300Z Fri.

③ Cir not auth S of Rwy 10-28. ④ When ALS inop, increase RVR to 24, vis to 1/2. ⑤ When ALS inop, increase RVR to 40, vis to 3/4. ⑥ When ALS inop, increase vis CAT ABC RVR to 50, vis to 1 mile, CAT DE RVR to 60, vis to 1 1/4. ⑦ When ALS inop, increase CAT AB RVR to 50, vis to 1 mile, CAT C RVR to 60, vis to 1 1/4, CAT DE vis to 1 1/2.

