

AD 2 AERODROMES

RJSC AD 2.1 AERODROME LOCATION INDICATOR AND NAME

RJSC - YAMAGATA

RJSC AD 2.2 AERODROME GEOGRAPHICAL AND ADMINISTRATIVE DATA

1	ARP coordinates and site at AD	382443N 1402216E 006°/ 1.0km from RWY 01 THR
2	Direction and distance from (city)	10.2nm NNE from Yamagata city
3	Elevation/ Reference temperature	345ft / 30 °C (2004-2008)
4	Geoid undulation at AD ELEV PSN	135ft
5	MAG VAR/ Annual change	8°W (2016) /0°E
6	AD Administration, address, telephone, telefax, telex, AFS, e-mail and/or Web-site addresses	Yamagata Airport Office(Yamagata Pref) 3008 Kashiwabarashinrin Hanyuu Higashine-shi Yamagata 999-3776 Japan Tel: 0237-48-1313 Fax: 0237-48-1659 e-mail:yyamakuko@pref.yamagata.jp Web-site: http://www.pref.yamagata.jp/
7	Types of traffic permitted (IFR/ VFR)	IFR/VFR
8	Remarks	Yamagata Airport Branch(CAB) 3008, Shinrin, Aza-Kashiwabara, Oaza-Hanyu, Higashine-shi, Yamagata Pref. Tel: 0237-48-1118

RJSC AD 2.3 OPERATIONAL HOURS

1	AD Administration	2300 - 1100
2	Customs and immigration	On request Customs: 023-641-0504 Immigration: 0234-22-2746
3	Health and sanitation	On request Quarantine(human): 022-367-8101 Quarantine(animal): 022-383-2302 Quarantine(plant): 022-362-6916
4	AIS Briefing Office	Nil
5	ATS Reporting Office(ARO)	Nil
6	MET Briefing Office	H24 (SENDAI)
7	ATS	2300 - 1100
8	Fuelling	2300 - 1100
9	Handling	2300 - 1100
10	Security	2300 - 1100
11	De-icing	Nil
12	Remarks	Nil

RJSC AD 2.4 HANDLING SERVICES AND FACILITIES

1	Cargo-handling facilities	2t-forklift car x 1, 7m-belt loading car x 2, Available up to only bulk loading aircraft.
2	Fuel/ oil types	JET A-1
3	Fuelling facilities/ capacity	Fuel truck / 200kl(JET A-1)
4	De-icing facilities	De-icing car
5	Hangar space for visiting aircraft	Nil
6	Repair facilities for visiting aircraft	Nil
7	Remarks	Nil

RJSC AD 2.5 PASSENGER FACILITIES

1	Hotels	around Airport
2	Restaurants	At Airport
3	Transportation	Airport Shuttle(Reservation required) and Taxi
4	Medical facilities	Hospital in Higashine city 6km
5	Bank and Post Office	Bank in Higashine city, Post Office in Higashine city
6	Tourist Office	Tourist Office in Higashine city
7	Remarks	Nil

RJSC AD 2.6 RESCUE AND FIRE FIGHTING SERVICES

1	AD category for fire fighting	CAT 7
2	Rescue equipment	Chemical fire fighting truck x 2
3	Capability for removal of disabled aircraft	A300,B767
4	Remarks	Nil

RJSC AD 2.7 SEASONAL AVAILABILITY-CLEARING

1	Types of clearing equipment	Snow remove equipments: truck x 10 , rotary x 3 , dozer x 1
2	Clearance priorities	RWY , TWY , Apron (The same)
3	Remarks	Nil

RJSC AD 2.8 APRONS, TAXIWAYS AND CHECK LOCATIONS DATA

1	Apron surface and strength	Apron : Surface:cement-concrete, Strength: PCN 53/R/C/X/T Small ACFT Apron: Surface:asphalt-concrete, Strength: AUW5,700kg/0.28Mpa
2	Taxiway width, surface and strength	Width:30m Surface:asphalt-concrete Strength: PCN 58/F/C/X/T
3	ACL and elevation	Not available
4	VOR checkpoints	Not available
5	INS checkpoints	Spot NR 1:382435.52N 1402201.11E 1-1:382436.27N 1402201.52E 2:382437.31N 1402201.73E 3:382439.26N 1402201.81E 5:382441.02N 1402201.68E
6	Remarks	Nil

RJSC AD 2.9 SURFACE MOVEMENT GUIDANCE AND CONTROL SYSTEM AND MARKINGS

1	Use of aircraft stand ID signs, TWY guide lines and Visual docking/ parking guidance system of aircraft stands	Nil
2	RWY and TWY markings and LGT	RWY:01/19 (Marking) RWY designation, RWY CL, RWY THR, TDZ, RWY side stripe, Aiming point, RWY turn pad edge, RWY turn pad CL, RWY turn pad aiming (LGT) RCLL, REDL, RTHL, RENL, RTZL(FOR RWY01), WBAR(FOR RWY01), RWY DIST marker LGT, Turning point indicator LGT TWY: (Marking) TWY CL, RWY HLDG PSN, TWY side stripe marking (LGT) TWY edge LGT, TWY CL LGT
3	Stop bars	Nil
4	Remarks	(Marking) Overrun area (LGT) Apron flood LGT

180° turn on RWY

B-767型機の滑走路180° 転回実施要領

1. 滑走路中心線からターニングパッド中心線標識に従って進行する。
2. 転回灯1が一直線に見えるように進行し、転回灯2が一直線に見えた時転回を開始する。転回時はMAX STEERING ANGLEを使用する。

Procedure of 180° turn on RWY for B-767 aircraft

1. Proceed along the RWY Turn Pad Center Line Marking.
2. Proceed along the RWY Turn Pad Center Line Marking to see the Turning Point Indicator Light 1 on a straight line, then commence turn at the spot where you (pilot) can see the Turning Point Indicator Light 2 on a straight line at an angle of 9 o'clock. When turning, take MAX STEERING ANGLE.

YAMAGATA AP

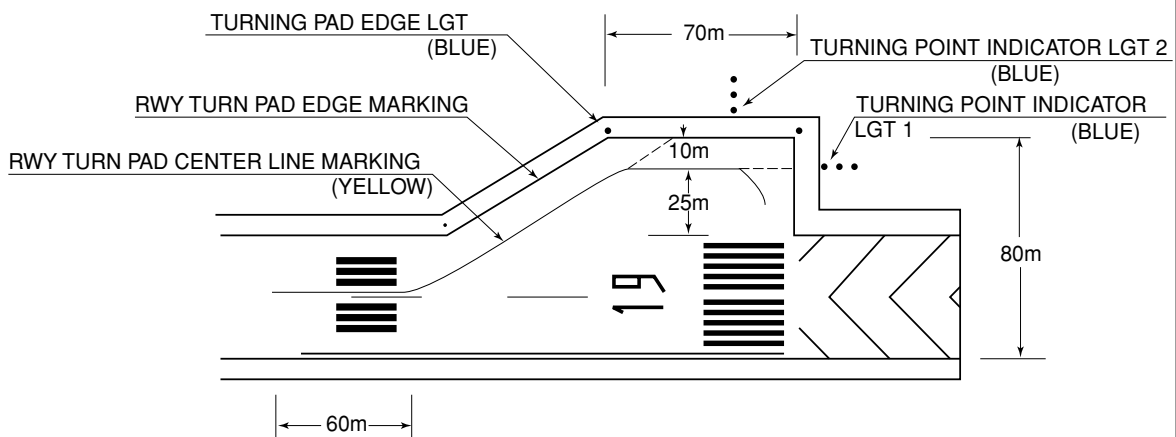
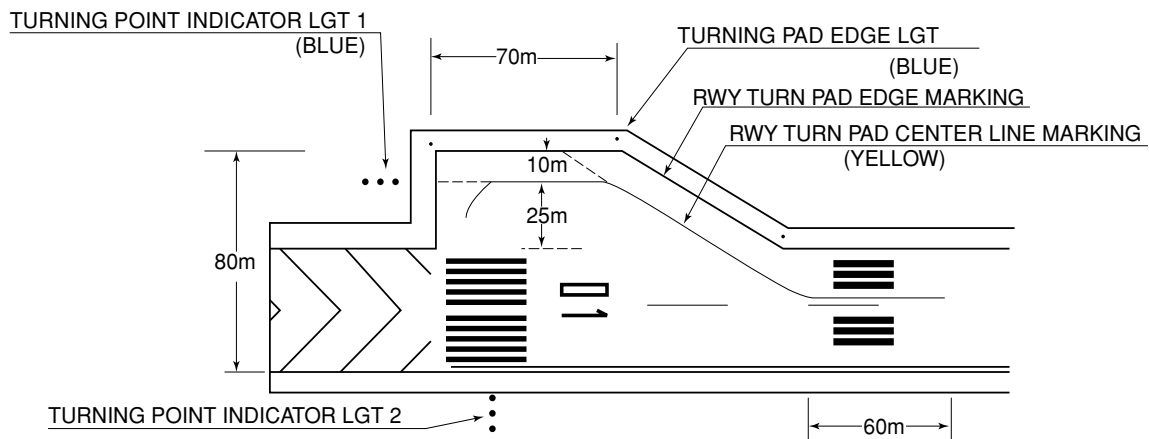

RJSC AD 2.10 AERODROME OBSTACLES

■ In Area2 See Obstacle data

■ In Area3 To be developed

RJSC AD 2.11 METEOROLOGICAL INFORMATION PROVIDED

1	Associated MET Office	SENDAI
2	Hours of service MET Office outside hours	H24 (SENDAI)
3	Office responsible for TAF preparation Periods of validity	Nil
4	Trend forecast Interval of issuance	Nil
5	Briefing/ consultation provided	Briefing is available upon inquiry at SENDAI
6	Flight documentation Language(s) used	C En
7	Charts and other information available for briefing or consultation	S ₆ , U ₈₅ , U ₇ , U ₅ , U ₃ , U ₂₅ , U ₂ /T _r , P _S , P ₅ , P ₃ , P ₂₅ , P _{SWE} , P _{SWF} , P _{SWG} , P _{SWI} , P _{SWM} , P _{SW} (domestic), E, C, W _E , W _F , W _G , W _I , W, N
8	Supplementary equipment available for providing information	Nil
9	ATS units provided with information	RADIO
10	Additional information(limitation of service, etc.)	Nil

RJSC AD 2.12 RUNWAY PHYSICAL CHARACTERISTICS

Designations RWY NR	TRUE BRG	Dimensions of RWY(M)	Strength(PCN) and surface of RWY	THR coordinates THR geoid undulation	THR elevation and highest elevation of TDZ of precision APP RWY
1	2	3	4	5	6
01	006.57°	2000×45	PCN 58/F/C/X/T Asphalt Concrete	382410.61N 1402212.06E 135.4FT	THR ELEV: 346.9ft TDZ ELEV: 346.9ft
19	186.57°	2000×45	PCN 58/F/C/X/T Asphalt Concrete	382515.04N 1402221.52E 135.4FT	THR ELEV: 353ft
Slope of RWY	Strip Dimensions(M)	RESA (Overrun) Dimensions(M)	Remarks		
7	10	11	14		
See AD2.24 AD chart	2120×300 2120×300	152 × (MNM:157 MAX:300)* 83 × (MNM:287 MAX:300)* *For detail, ask airport administrator	RWY grooving : 2000m×30m		

RJSC AD 2.13 DECLARED DISTANCES

RWY Designator	TORA (m)	TODA (m)	ASDA (m)	LDA (m)	Remarks
1	2	3	4	5	6
01	2000	2000	2000	2000	Nil
19	2000	2000	2000	2000	Nil

RJSC AD 2.14 APPROACH AND RUNWAY LIGHTING

RWY Designator	APCH LGT type LEN INTST	RTHL Color WBAR	PAPI (VASIS) Angle DIST FM THR MEHT	RTZL LEN	RCLL LEN Spacing Color INTST	REDL LEN Spacing Color INTST	RENL Color WBAR	STWL LEN Color
1	2	3	4	5	6	7	8	9
01	PALS (CAT I) 900m LIH	Green Green	PAPI 3.0° /Left 410m 61ft	900m	2000m 30m Coded color (White/Red) LIH	2000m 60m Coded color (White/Yellow) LIH	Red	Nil (*2)
19	SALS (*1) 420m LIH	Green Nil	PAPI 3.0°/Left 386.7m 61ft	Nil	2000m 30m Coded color (White/Red) LIH	2000m 60m Coded color (White/Yellow) LIH	Red	Nil (*2)
Remarks								
10								
SALS with APCH LGT beacon (600m and 900m FM RWY THR) (*1) Overrun area edge LGT(LEN:60m, color:Red) (*2) CGL for RWY 19								

RJSC AD 2.15 OTHER LIGHTING, SECONDARY POWER SUPPLY

1	ABN/IBN location, characteristics and hours of operation	ABN : 382445N/1402156E, White/Green EV4.3sec, HO
2	LDI location and LGT Anemometer location and LGT	LDI : Nil Anemometer : RWY01 : On the north side of 170m FM RWY01 THR, LGTD RWY19 : On the north side of 30m FM RWY19 THR, LGTD
3	TWY edge and center line lighting	TWY edge LGT : Blue TWY CL LGT : ALTN Green/Yellow FM RWY leaving Report point, other Green
4	Secondary power supply/switch-over time	Within 1sec : REDL, RCLL, RTHL, RENL, WBAR, Turning point indicator LGT, Overrun area edge LGT Within 15sec : Other LGT
5	Remarks	WDI LGT

RJSC AD 2.16 HELICOPTER LANDING AREA

Nil

RJSC AD 2.17 ATS AIRSPACE

Designation and lateral limits		Vertical limits (ft)	Airspace classification	ATS unit call sign Language	Remarks
1		2	3	4	6
Yamagata Information zone	Area within a radius of 9km(5NM) of ARP	3000 or below	E	Yamagata radio En	

RJSC AD 2.18 ATS COMMUNICATION FACILITIES

Service designation	Call sign	Frequency	Hours of operation	Remarks
1	2	3	4	5
A/G	Yamagata Radio	122.7MHz(1) 126.2MHz 243.0MHz(E)	2300 - 1100	(1)Primary

RJSC AD 2.19 RADIO NAVIGATION AND LANDING AIDS

Type of aid (VOR declination)	ID	Frequency	Hours of operation	Position of transmitting antenna coordinates	Elevation of DME transmit- ting antenna	Remarks
1	2	3	4	5	6	7
VOR (8°W/2016)	YTE	113MHz	H24	382319.04N 1402128.63E		VOR/DME Unusable: 030°-040° beyond 35nm BLW 8000ft. 040°-060° beyond 25nm BLW 8000ft. 060°-070° beyond 15nm BLW 8000ft. 070°-080° beyond 15nm BLW 7000ft. 080°-110° beyond 20nm BLW 7000ft. 110°-150° beyond 15nm BLW 7000ft. 150°-160° beyond 25nm BLW 9000ft. 160°-170° beyond 30nm BLW 9000ft. 170°-180° beyond 25nm BLW 9000ft. 250°-260° beyond 35nm BLW 9000ft. 260°-270° beyond 35nm BLW 8000ft. 300°-320° beyond 30nm BLW 9000ft. 320°-330° beyond 20nm BLW 9000ft. 330°-340° beyond 30nm BLW 10000ft.
DME	YTE	1164MHz (CH-77X)	H24	382319.04N 1402128.63E	361ft	
ILS-LOC 01	IYT	110.1MHz	2300 - 1100	382522.13N 1402222.56E		LOC: 220m(722ft) away FM RWY 19 THR, BRG(MAG) 014° LOC Unusable in the following area (1)beyond 10 degrees East side of LOC course. (2)beyond 8 degrees East side of LOC course beyond 17NM fm LOC antenna.
ILS-GP 01	-	334.4MHz	2300 - 1100	382420.71N 1402218.52E		GP : 328m(1076ft) inside FM RWY 01 THR, 120m (394ft) E of RCL, angle 3.0°HGT of ILS Ref datum 16.5m(54ft).
ILS-DME 01	IYT	999MHz	2300 - 1100	382420.70N 1402218.94E	362ft	DME :328m(1076ft)inside FM RWY 01,130m(427ft) E of RCL.
MSAS		1575.42MHz	H24			Transmitting antennas are satellite based.

ILS

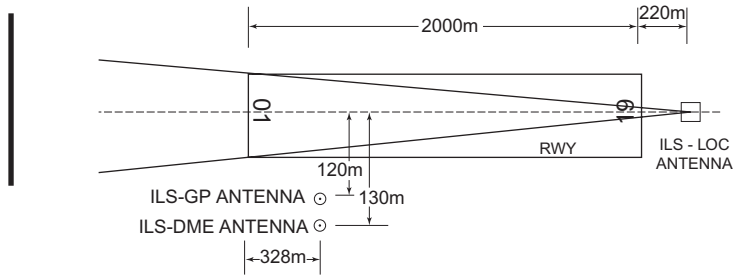

- REMARKS : 1. LOC beam BRG(MAG) 014°
 2. HGT of ILS REF datum 16.5m(54ft)
 3. GP Angle 3.0°
 4. ELEV of ILS-DME 110.4m(362ft)

LOC unusable is the following area : (1) beyond 10° East side of LOC course.
 (2) beyond 8° East side of LOC course beyond 17nm from LOC ANT.

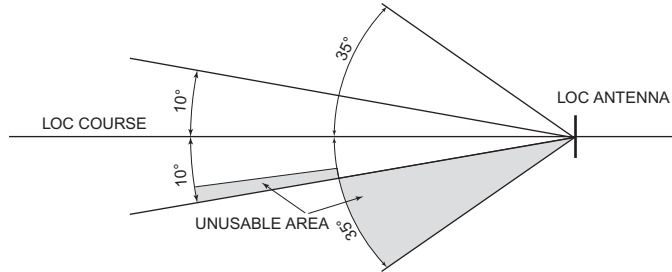

RJSC AD 2.20 LOCAL TRAFFIC REGULATIONS

1. Airport regulations

On use of YAMAGATA airport, aircraft operator is required to notify the airport administrator in advance.

2. Taxiing to and from stands

Nil

3. Parking area for small aircraft(General aviation)

Nil

4. Parking area for helicopters

Nil

5. Apron - taxiing during winter conditions

Nil

6. Taxiing - limitations

Nil

7. School and training flights - technical test flights - use of runways

Nil

8. Helicopter traffic - limitation

Nil

9. Removal of disabled aircraft from runways

Nil

RJSC AD 2.21 NOISE ABATEMENT PROCEDURES

Nil

RJSC AD 2.22 FLIGHT PROCEDURES

1. TAKE OFF MINIMA

	RWY	ACFT CAT	REDL & RCLL		REDL or RCLL or RCL Marking		NIL (DAYTIME ONLY)	
			RVR	VIS	RVR	VIS	RVR	VIS
Multi-Engine ACFT with TKOF ALTN AP FILED	01	A,B,C,D	400	400	400	400	-	500
	19	A,B,C,D	-	400	-	400	-	500
OTHER	01	A,B,C,D	AVBL LDG MINIMA					
	19	A,B,C,D						

2. OTHER

VFR aircraft intending to land on or fly around the AP, especially south and north of the AP, is recommended to make initial contact with Yamagata RADIO to obtain traffic information at least 15nm far from the AP.

当空港に着陸または空港周辺、特に空港の南及び北側を飛行しようとするVFRの航空機については、交通情報の入手のため、少なくとも15NM以遠からの山形RADIOとの通信設定が推奨される。

RJSC AD 2.23 ADDITIONAL INFORMATION

Nil

RJSC AD 2.24 CHARTS RELATED TO AN AERODROME

Aerodrome/Heliport Chart
Standard Departure Chart - Instrument (YAMAGATA)
Standard Departure Chart - Instrument (RUBIS-RNAV)
Standard Departure Chart - Instrument (NIIGATA-RNAV)
Standard Departure Chart - Instrument (HANKA-RNAV)
Standard Arrival Chart - Instrument (YOZAN WEST, YOZAN NORTH-RNAV)
Standard Arrival Chart - Instrument (MEDET WEST, MEDET SOUTH-RNAV)
Standard Arrival Chart - Instrument (TUYAH-RNAV)
Instrument Approach Chart (ILS Z RWY01)
Instrument Approach Chart (LOC Z RWY01)
Instrument Approach Chart (ILS Y RWY01)
Instrument Approach Chart (LOC Y RWY01)
Instrument Approach Chart (VOR A)
Instrument Approach Chart (RNAV(GNSS) RWY19)
Other Chart (Visual REP)
Other Chart (LDG CHART)
Other Chart (MVA CHART)

RJSC / YAMAGATA

AD CHART

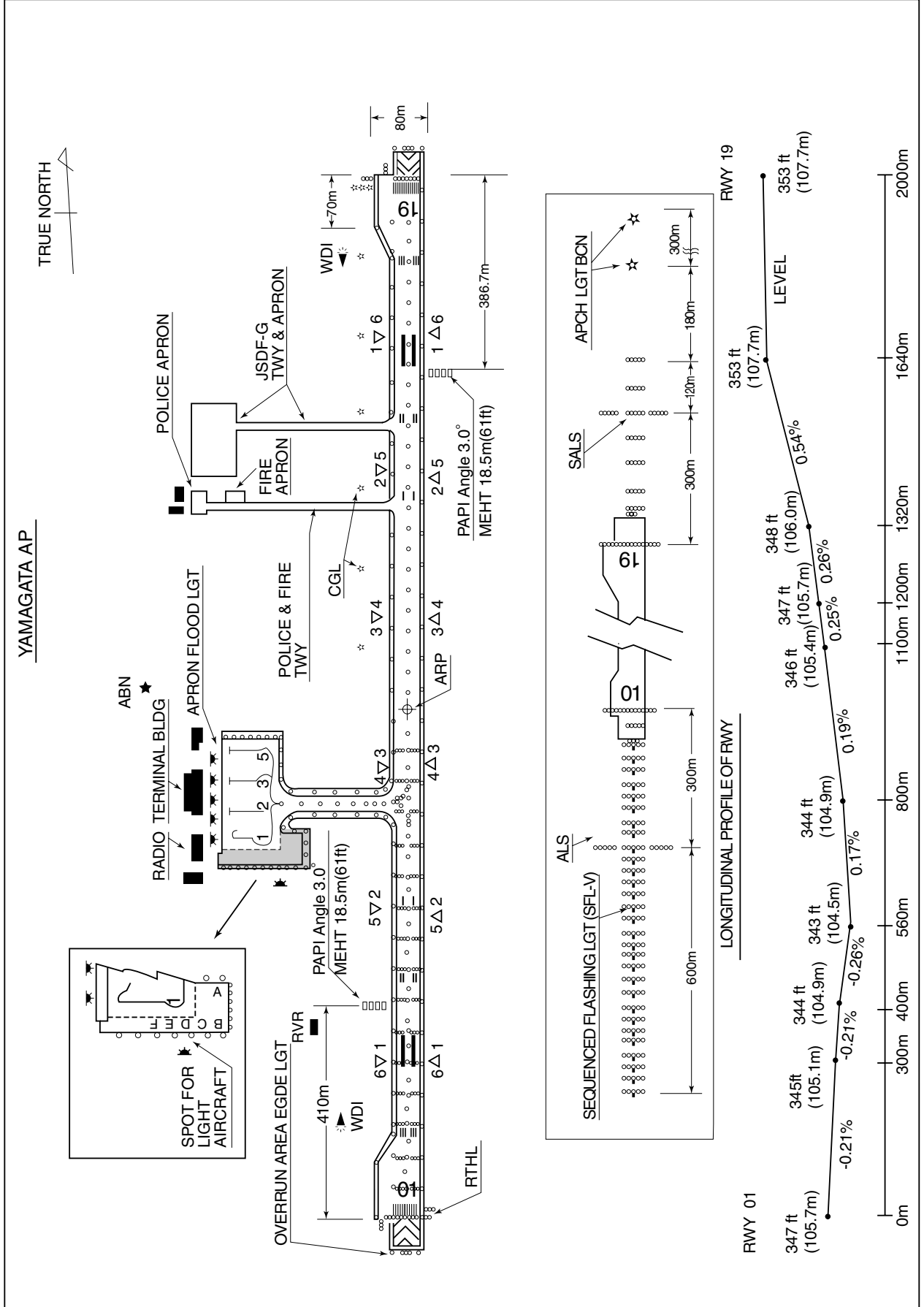

STANDARD DEPARTURE CHART-INSTRUMENT

RJSC / YAMAGATA

RNAV SID

NIIGATA ONE DEPARTURE

Basic RNP1

Note GNSS required.

VAR 8°W (2017)

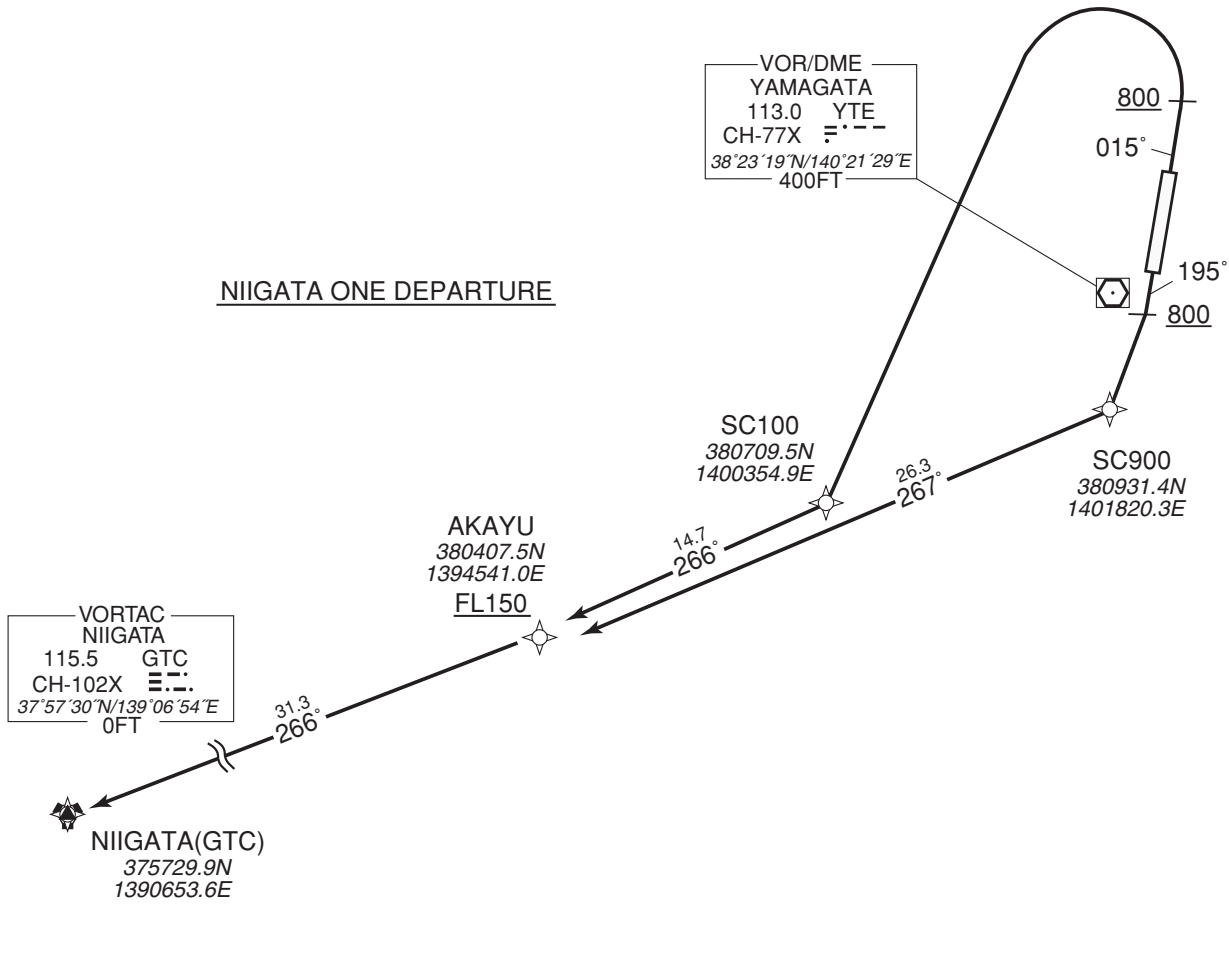

NIIGATA ONE DEPARTURE

VOR/DME
YAMAGATA
113.0 YTE
CH-77X
38°23'19"N/140°21'29"E
400FT

VORTAC
NIIGATA
115.5 GTC
CH-102X
37°57'30"N/139°06'54"E
0FT

NIIGATA(GTC)
375729.9N
1390653.6E

SC100
380709.5N
1400354.9E

SC900
380931.4N
1401820.3E

AKAYU
380407.5N
1394541.0E
FL150

NIIGATA ONE DEPARTURE

RWY01 : Climb on HDG015° at or above 800FT, turn left direct to SC100,...
RWY19 : Climb on HDG195° at or above 800FT, direct to SC900,...
... to AKAYU at or above FL150, to GTC.

Note RWY01 : 5.5% climb gradient required up to 2500FT.
OBST ALT 2198FT located at 6.3NM 321° FM end of RWY01.
RWY19 : 4.3% climb gradient required up to 800FT.
OBST ALT 722FT located at 2.8NM 182° FM end of RWY19.

CHANGE : New PROC

STANDARD DEPARTURE CHART-INSTRUMENT

RJSC / YAMAGATA

RNAV SID

NIIGATA ONE DEPARTURE

RWY01

Serial Number	Path Descriptor	Waypoint Identifier	Fly Over	Course °M(°T)	Magnetic Variation	Distance (NM)	Turn Direction	Altitude (FT)	Speed (KIAS)	Vertical Angle	Navigation Specification
001	VA	—	—	015 (006.6)	-8.2	—	—	+800	—	—	Basic RNP1
002	DF	SC100	—	—	-8.2	—	L	—	—	—	Basic RNP1
003	TF	AKAYU	—	266 (258.2)	-8.2	14.7	—	+FL150	—	—	Basic RNP1
004	TF	GTC	—	266 (258.0)	-8.2	31.3	—	—	—	—	Basic RNP1

RWY19

Serial Number	Path Descriptor	Waypoint Identifier	Fly Over	Course °M(°T)	Magnetic Variation	Distance (NM)	Turn Direction	Altitude (FT)	Speed (KIAS)	Vertical Angle	Navigation Specification
001	VA	—	—	195 (186.6)	-8.2	—	—	+800	—	—	Basic RNP1
002	DF	SC900	—	—	-8.2	—	—	—	—	—	Basic RNP1
003	TF	AKAYU	—	267 (258.3)	-8.2	26.3	—	+FL150	—	—	Basic RNP1
004	TF	GTC	—	266 (258.0)	-8.2	31.3	—	—	—	—	Basic RNP1

CHANGE : New PROC

STANDARD DEPARTURE CHART-INSTRUMENT

RJSC / YAMAGATA

RNAV SID

HANKA ONE DEPARTURE

Basic RNP1

Note GNSS required.

VAR 8°W (2017)

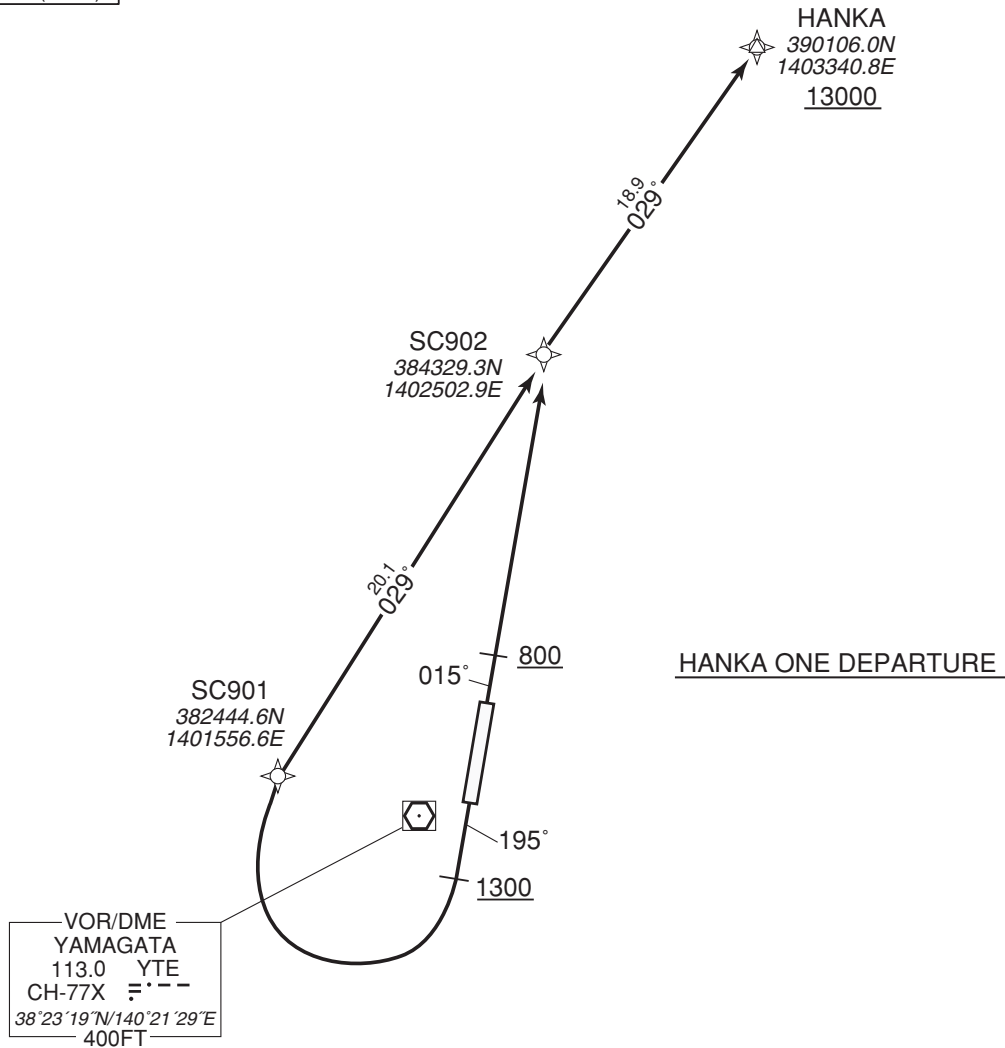

HANKA ONE DEPARTURE

RWY01 : Climb on HDG015° at or above 800FT, direct to SC902,...
 RWY19 : Climb on HDG195° at or above 1300FT, turn right direct to SC901, to SC902,...
 ... to HANKA at or above 13000FT.

Note RWY01 : 5.0% climb gradient required up to 800FT.
 OBST ALT 1542FT located at 6.5NM 026° FM end of RWY01.
 RWY19 : 4.0% climb gradient required up to 1300FT.
 OBST ALT 919FT located at 3.2NM 181° FM end of RWY19.
 No turn before DER.

CHANGE : New PROC

STANDARD DEPARTURE CHART-INSTRUMENT

RJSC / YAMAGATA

RNAV SID

HANKA ONE DEPARTURE

RWY01

Serial Number	Path Descriptor	Waypoint Identifier	Fly Over	Course °M(°T)	Magnetic Variation	Distance (NM)	Turn Direction	Altitude (FT)	Speed (KIAS)	Vertical Angle	Navigation Specification
001	VA	—	—	015 (006.6)	-8.2	—	—	+800	—	—	Basic RNP1
002	DF	SC902	—	—	-8.2	—	—	—	—	—	Basic RNP1
003	TF	HANKA	—	029 (020.8)	-8.2	18.9	—	+13000	—	—	Basic RNP1

RWY19

Serial Number	Path Descriptor	Waypoint Identifier	Fly Over	Course °M(°T)	Magnetic Variation	Distance (NM)	Turn Direction	Altitude (FT)	Speed (KIAS)	Vertical Angle	Navigation Specification
001	VA	—	—	195 (186.6)	-8.2	—	—	+1300	—	—	Basic RNP1
002	DF	SC901	—	—	-8.2	—	R	—	—	—	Basic RNP1
003	TF	SC902	—	029 (020.7)	-8.2	20.1	—	—	—	—	Basic RNP1
004	TF	HANKA	—	029 (020.8)	-8.2	18.9	—	+13000	—	—	Basic RNP1

CHANGE : Editorial

STANDARD ARRIVAL CHART - INSTRUMENT

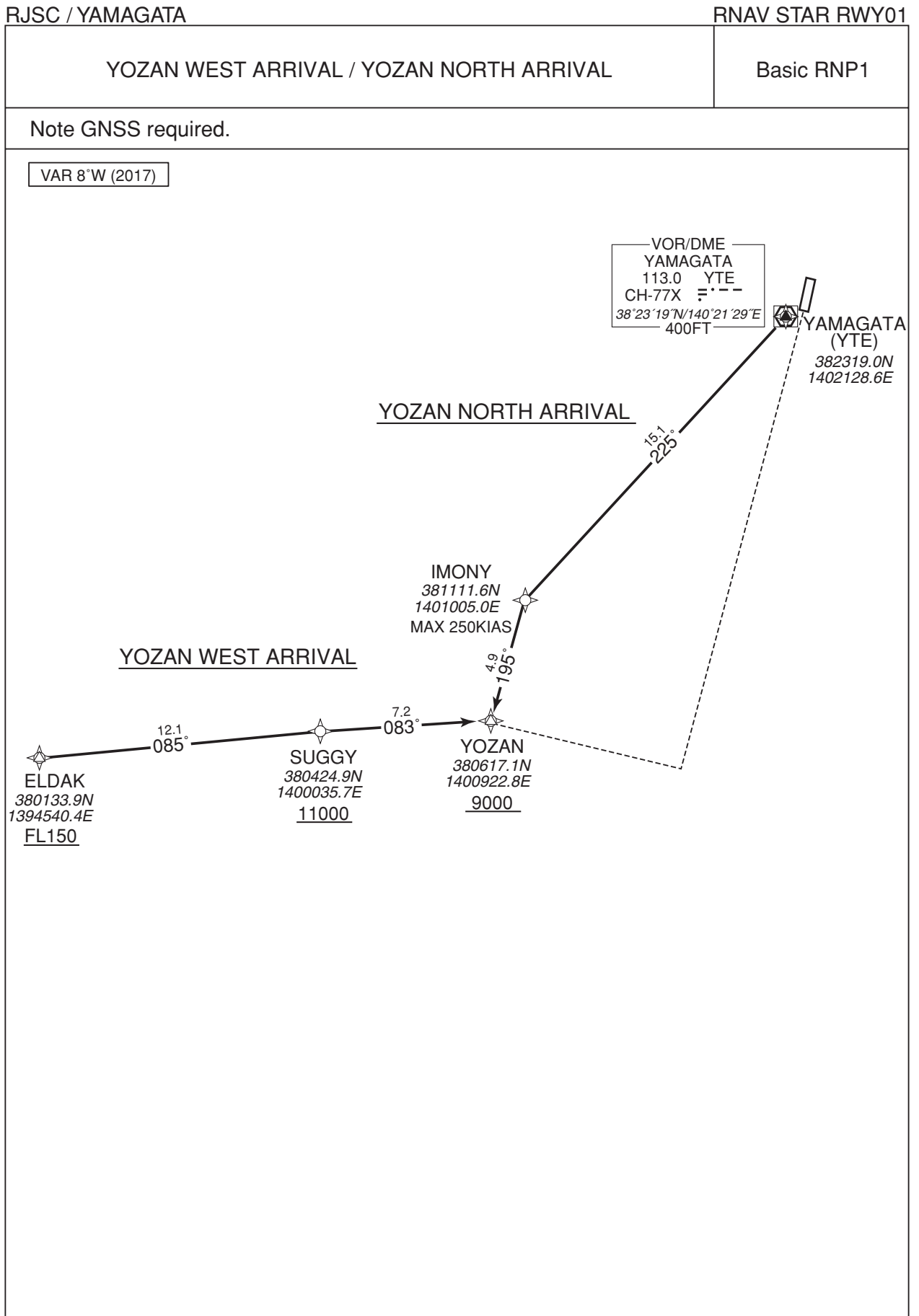

CHANGE : New PROC

STANDARD ARRIVAL CHART - INSTRUMENT

RJSC / YAMAGATA

RNAV STAR RWY01

YOZAN WEST ARRIVAL

From ELDAK at or above FL150, to SUGGY at or above 11000FT, to YOZAN at or above 9000FT.

Serial Number	Path Descriptor	Waypoint Identifier	Fly Over	Course °M(°T)	Magnetic Variation	Distance (NM)	Turn Direction	Altitude (FT)	Speed (KIAS)	Vertical Angle	Navigation Specification
001	IF	ELDAK	-	-	-8.2	-	-	+FL150	-	-	Basic RNP1
002	TF	SUGGY	-	085 (076.3)	-8.2	12.1	-	+11000	-	-	Basic RNP1
003	TF	YOZAN	-	083 (074.8)	-8.2	7.2	-	+9000	-	-	Basic RNP1

YOZAN NORTH ARRIVAL

From YTE, to IMONY, to YOZAN at or above 9000FT.

Serial Number	Path Descriptor	Waypoint Identifier	Fly Over	Course °M(°T)	Magnetic Variation	Distance (NM)	Turn Direction	Altitude (FT)	Speed (KIAS)	Vertical Angle	Navigation Specification
001	IF	YTE	-	-	-8.2	-	-	-	-	-	Basic RNP1
002	TF	IMONY	-	255 (216.5)	-8.2	15.1	-	-	-250	-	Basic RNP1
003	TF	YOZAN	-	195 (186.4)	-8.2	4.9	-	+9000	-	-	Basic RNP1

CHANGE : New PROC

STANDARD ARRIVAL CHART - INSTRUMENT

RJSC / YAMAGATA

RNAV STAR RWY19

MEDET WEST ARRIVAL / MEDET SOUTH ARRIVAL

Basic RNP1

Note GNSS required.

VAR 8°W (2017)

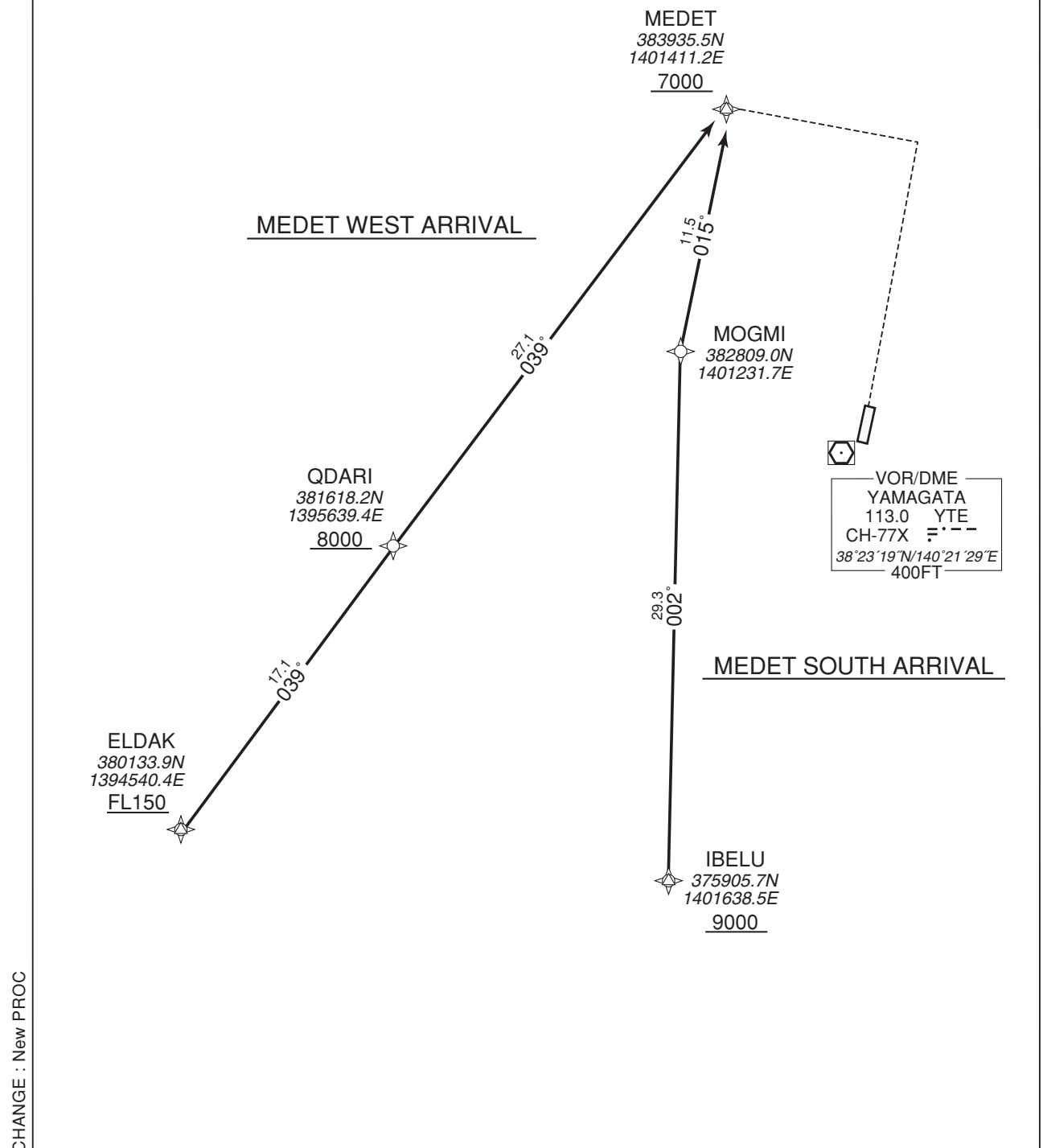

CHANGE : New PROC

STANDARD ARRIVAL CHART - INSTRUMENT

RJSC / YAMAGATA

RNAV STAR RWY19

MEDET WEST ARRIVAL

From ELDAK at or above FL150, to QDARI at or above 8000FT, to MEDET at or above 7000FT.

Serial Number	Path Descriptor	Waypoint Identifier	Fly Over	Course °M(°T)	Magnetic Variation	Distance (NM)	Turn Direction	Altitude (FT)	Speed (KIAS)	Vertical Angle	Navigation Specification
001	IF	ELDAK	—	—	-8.2	—	—	+FL150	—	—	Basic RNP1
002	TF	QDARI	—	039 (030.3)	-8.2	17.1	—	+8000	—	—	Basic RNP1
003	TF	MEDET	—	039 (030.4)	-8.2	27.1	—	+7000	—	—	Basic RNP1

MEDET SOUTH ARRIVAL

From IBELU at or above 9000FT, to MOGMI, to MEDET at or above 7000FT.

Serial Number	Path Descriptor	Waypoint Identifier	Fly Over	Course °M(°T)	Magnetic Variation	Distance (NM)	Turn Direction	Altitude (FT)	Speed (KIAS)	Vertical Angle	Navigation Specification
001	IF	IBELU	—	—	-8.2	—	—	+9000	—	—	Basic RNP1
002	TF	MOGMI	—	002 (353.7)	-8.2	29.3	—	—	—	—	Basic RNP1
003	TF	MEDET	—	015 (006.5)	-8.2	11.5	—	+7000	—	—	Basic RNP1

CHANGE : New PROC

STANDARD ARRIVAL CHART - INSTRUMENT

RJSC / YAMAGATA RNAV STAR RWY19

TUYAH ARRIVAL

Basic RNP1

Note GNSS required.

VAR 8°W (2017)

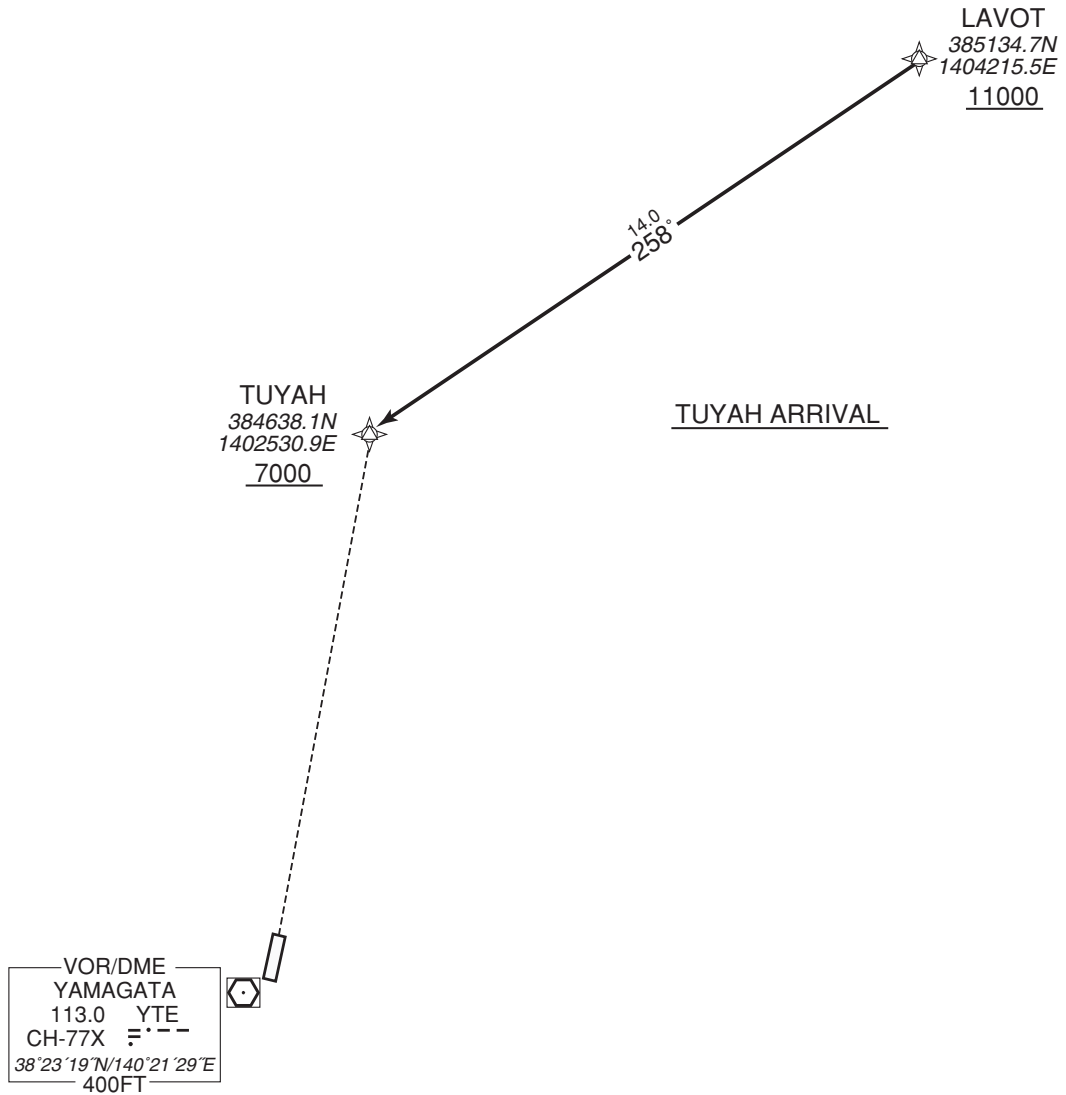

TUYAH ARRIVAL

From LAVOT at or above 11000FT, to TUYAH at or above 7000FT.

CHANGE : New PROC

Serial Number	Path Descriptor	Waypoint Identifier	Fly Over	Course °M(°T)	Magnetic Variation	Distance (NM)	Turn Direction	Altitude (FT)	Speed (KIAS)	Vertical Angle	Navigation Specification
001	IF	LAVOT	-	-	-8.2	-	-	+11000	-	-	Basic RNP1
002	TF	TUYAH	-	258 (249.3)	-8.2	14.0	-	+7000	-	-	Basic RNP1

INSTRUMENT APPROACH CHART

RJSC / YAMAGATA

RNAV(GNSS) RWY19

TOKYO CONTROL 118.9 - 276.8 135.9 - 230.6	1. DME/DME RNP0.3 not authorized. 2. RNP0.3 required. 3. GNSS required.	YAMAGATA RADIO 122.7 - 126.2	NO RADAR
---	--	---------------------------------	----------

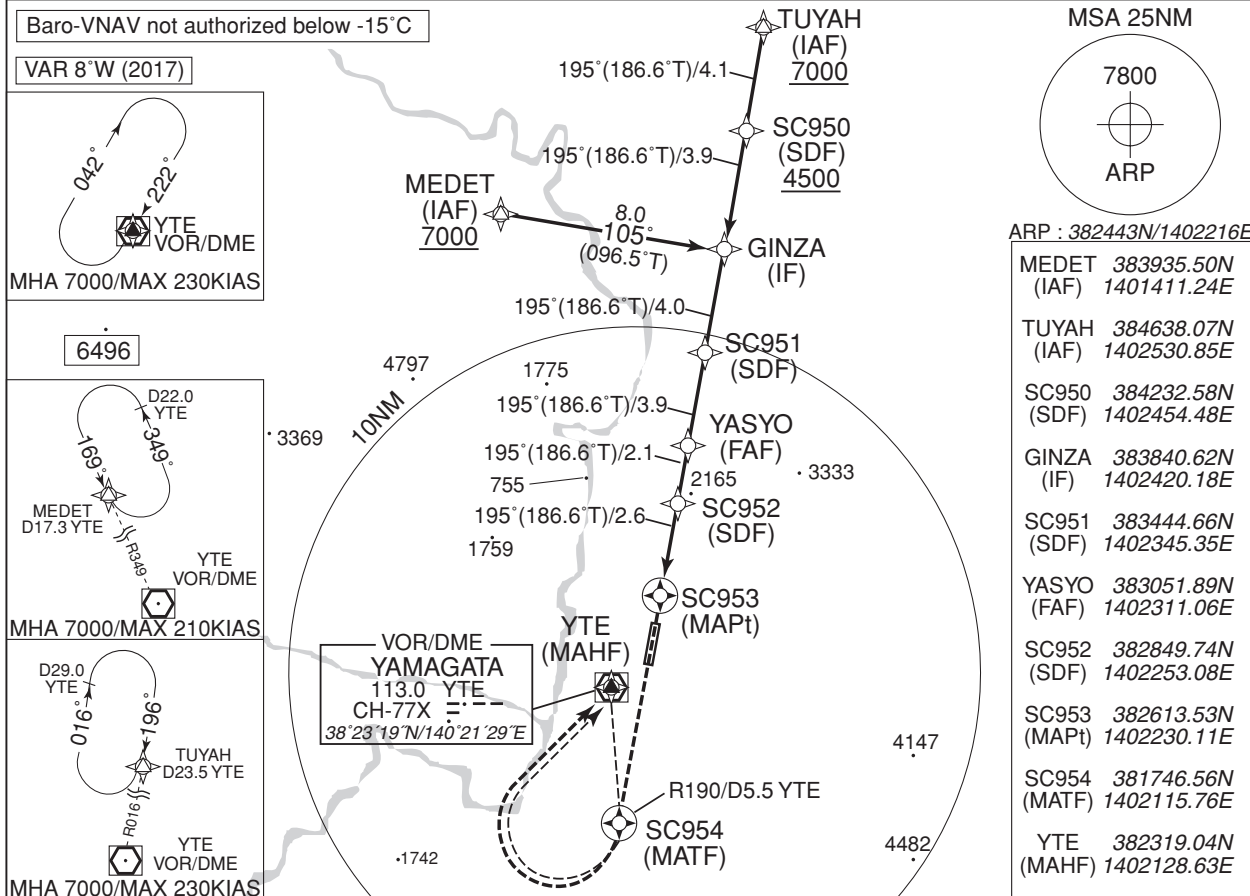

	MAPt	1	2	3	4	FAF	NM to Next Fix
	-	1033	1351	1670	1988	2200	ALT (3.0° APCH Path)

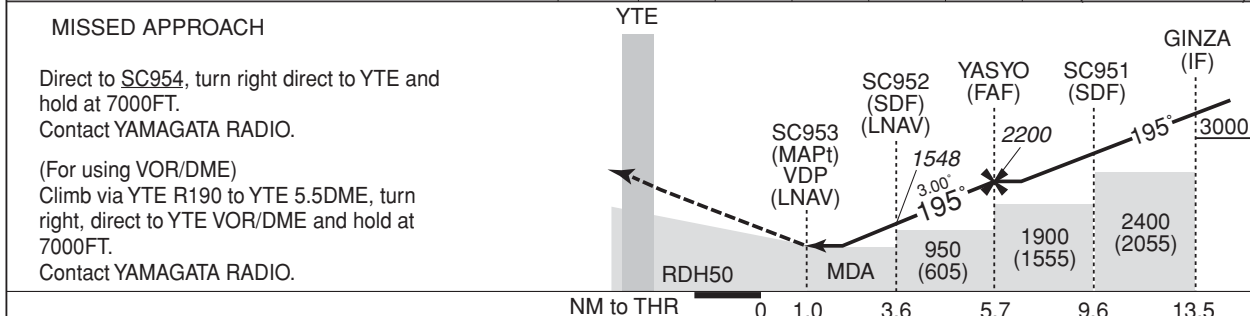

MISSED APCH climb gradient MNM 5.0%

MINIMA		THR elev. 353		AD elev. 345		
CAT	LNAV/VNAV		LNAV		CIRCLING	
	DA(H)	CMV	MDA(H)	CMV	MDA(H)	VIS
A	720 (367)	1200	720 (375)	1200	790 (445)	1600
B		1300		1300	800 (455)	
C		1400		1400	2400	
D		1600		1600	900 (555)	3200

MINIMA with Missed APCH climb gradient of 2.5% are not established.
Circling to WEST side of RWY only.

INSTRUMENT APPROACH CHART

RJSC / YAMAGATA

ILS Y RWY01

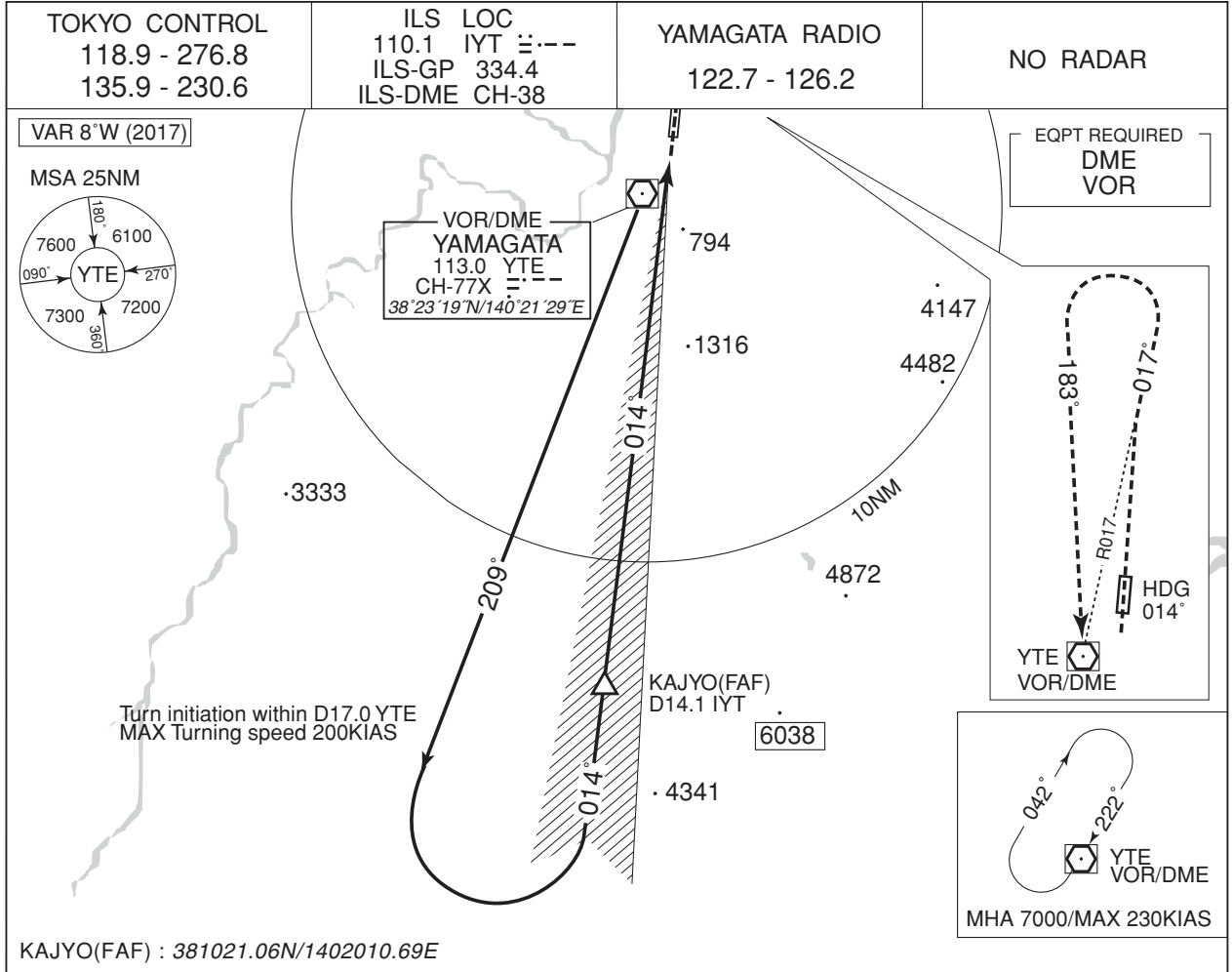

KAJYO(FAF) : 381021.06N/1402010.69E

Turn initiation within D17.0 YTE

MISSED APPROACH
Climb to 2000FT on HDG014°,
via YTE R017 to 5000FT,
turn left, via YTE R003 to YTE
VOR/DME and hold at 7000FT.
Contact YAMAGATA RADIO.

14.1	0.2	DME to IYT
13.9	0	NM to THR

Missed APCH climb gradient MNM 5.0%

	MINIMA	THR elev. 347	AD elev. 345
CAT	CAT I	CIRCLING	
	DA(H)	RVR/ CMV	MDA(H) VIS
A	547 (200)	550	790 (445) 1600
B			800 (455) 2400
C			900 (555) 3200
D			

MINIMA with Missed APCH climb gradient of 2.5% are not established.
Circling to WEST side of RWY only.

CHANGE : New PROC

INSTRUMENT APPROACH CHART

RJSC / YAMAGATA

LOC Y RWY01

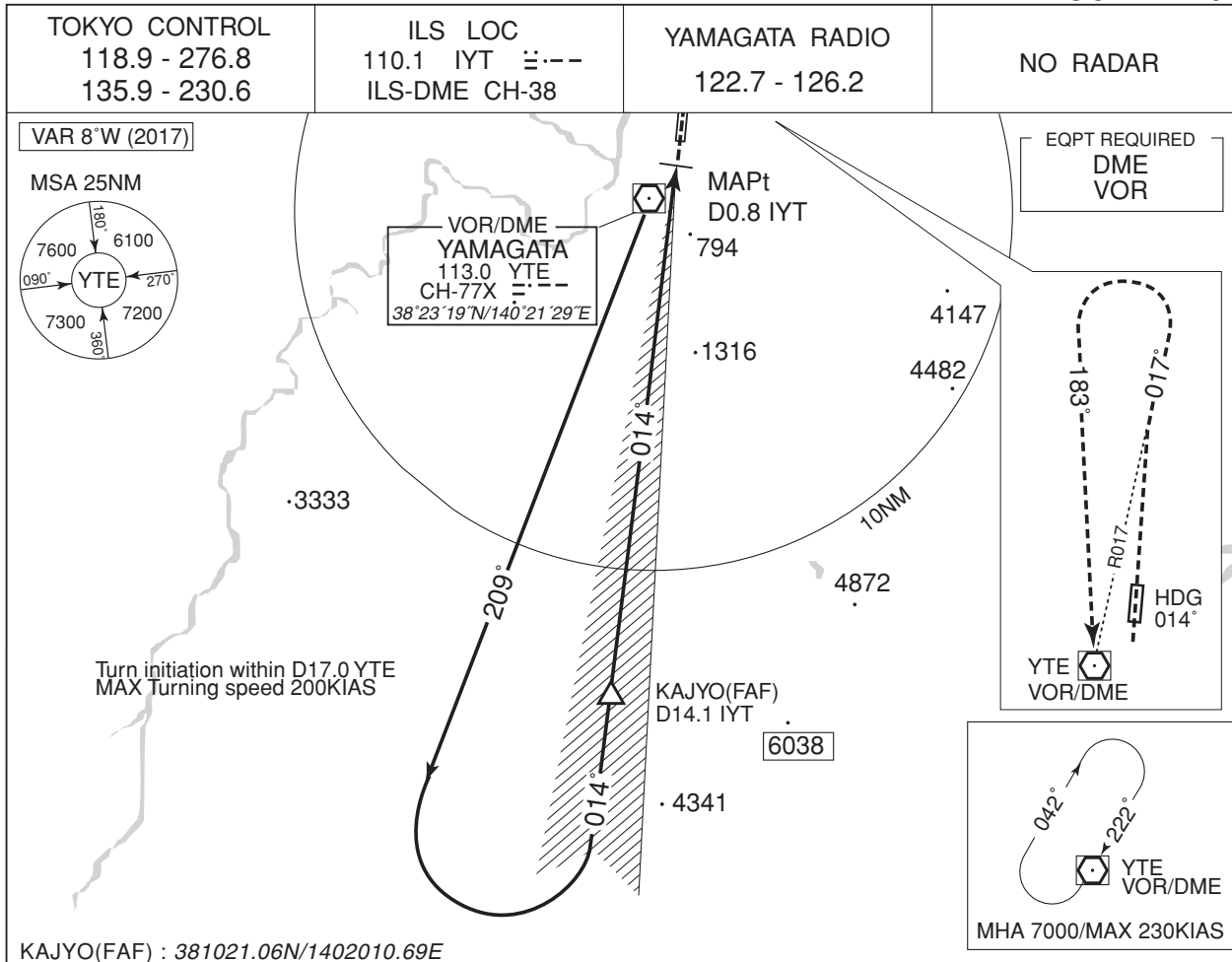

KAJYO(FAF) : 381021.06N/1402010.69E

NM to IYT	FAF	14	13	12	11	10	9	8	7	6	5	4	3	2	MAPt
ALT(3.1° APCH Path)	4969	4945	4616	4286	3957	3628	3299	2970	2641	2312	1983	1654	1325	995	-

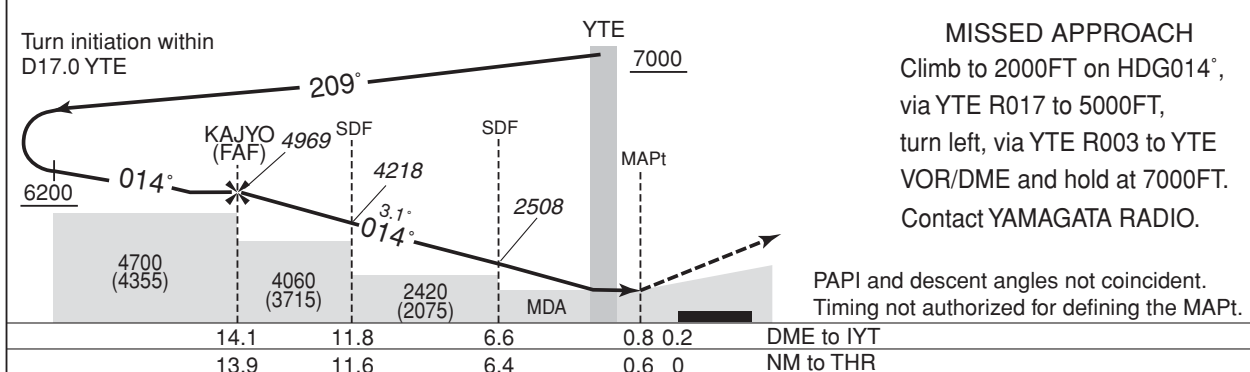

MISSED APPROACH
Climb to 2000FT on HDG014°,
via YTE R017 to 5000FT,
turn left, via YTE R003 to YTE
VOR/DME and hold at 7000FT.
Contact YAMAGATA RADIO.

PAPI and descent angles not coincident.
Timing not authorized for defining the MAPt.

Missed APCH climb gradient MNM 5.0%

MINIMA		THR elev. 347		AD elev. 345	
CAT	MDA(H)		CIRCLING		
			RVR/CMV	MDA(H)	VIS
	870 (525)	1000	870 (525)	1600	
		1200			2400
D	1600	900 (555)	3200		

MINIMA with Missed APCH climb gradient of 2.5% are not established.
Circling to WEST side of RWY only.

CHANGE : New PROC

STANDARD DEPARTURE CHART-INSTRUMENT

RJSC / YAMAGATA

SID

YAMAGATA FOUR DEPARTURE

RWY01 : Climb RWY HDG to 2000FT, via YTE R017 to 22.0DME, turn left, via YTE R003 to YTE VOR/DME.

RWY19 : Climb RWY HDG to 2000FT, turn right, direct to YTE VOR/DME, cross YTE VOR/DME at or above 4000FT, via YTE R017 to 15.0DME, turn left, via YTE R354 to YTE VOR/DME.

Note RWY01: 5.0% climb gradient required up to 2000FT.

OBST ALT 1182FT located at 4.2NM 033° FM end of RWY01.

RWY19: 5.0% climb gradient required up to 2000FT.

OBST ALT 788FT located at 3.1NM 181° FM end of RWY19.

Note No turn before DER.

For RWY01

For RWY19

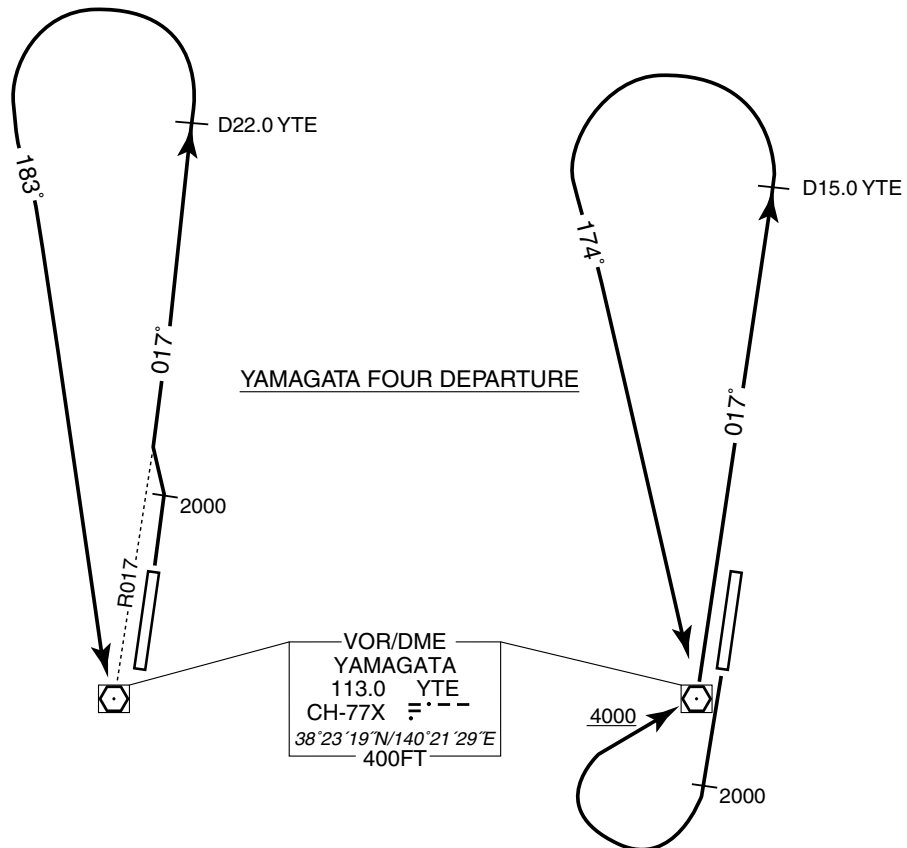

INSTRUMENT APPROACH CHART

RJSC / YAMAGATA

ILS Z RWY01

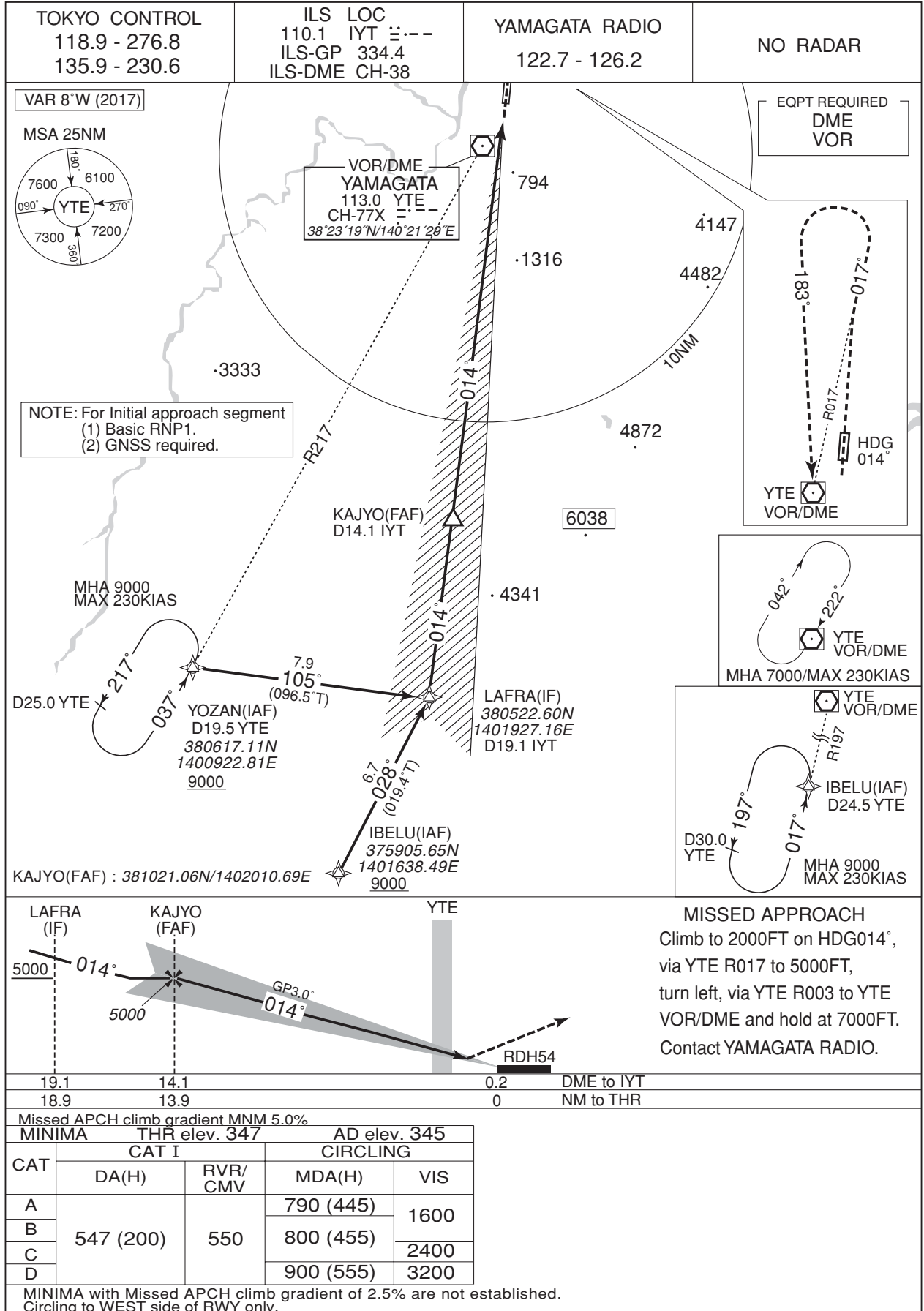

CHANGE : New PROC

INSTRUMENT APPROACH CHART

RJSC / YAMAGATA

VOR A

TOKYO CONTROL 118.9 - 276.8 135.9 - 230.6	YAMAGATA VOR/DME 113.0 YTE CH-77X 38°23'19"N/140°21'29"E	YAMAGATA RADIO 122.7 - 126.2	NO RADAR
---	---	---------------------------------	----------

VAR 8°W (2016)

6496

EQPT REQUIRED
DME

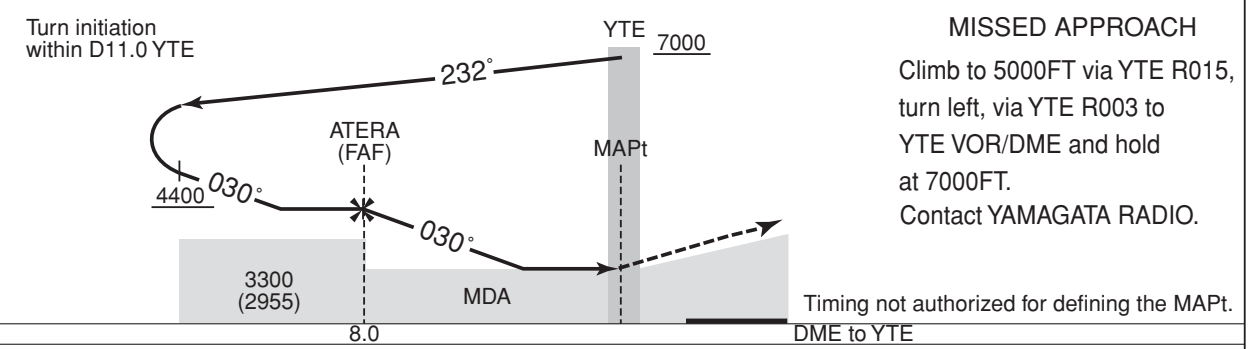
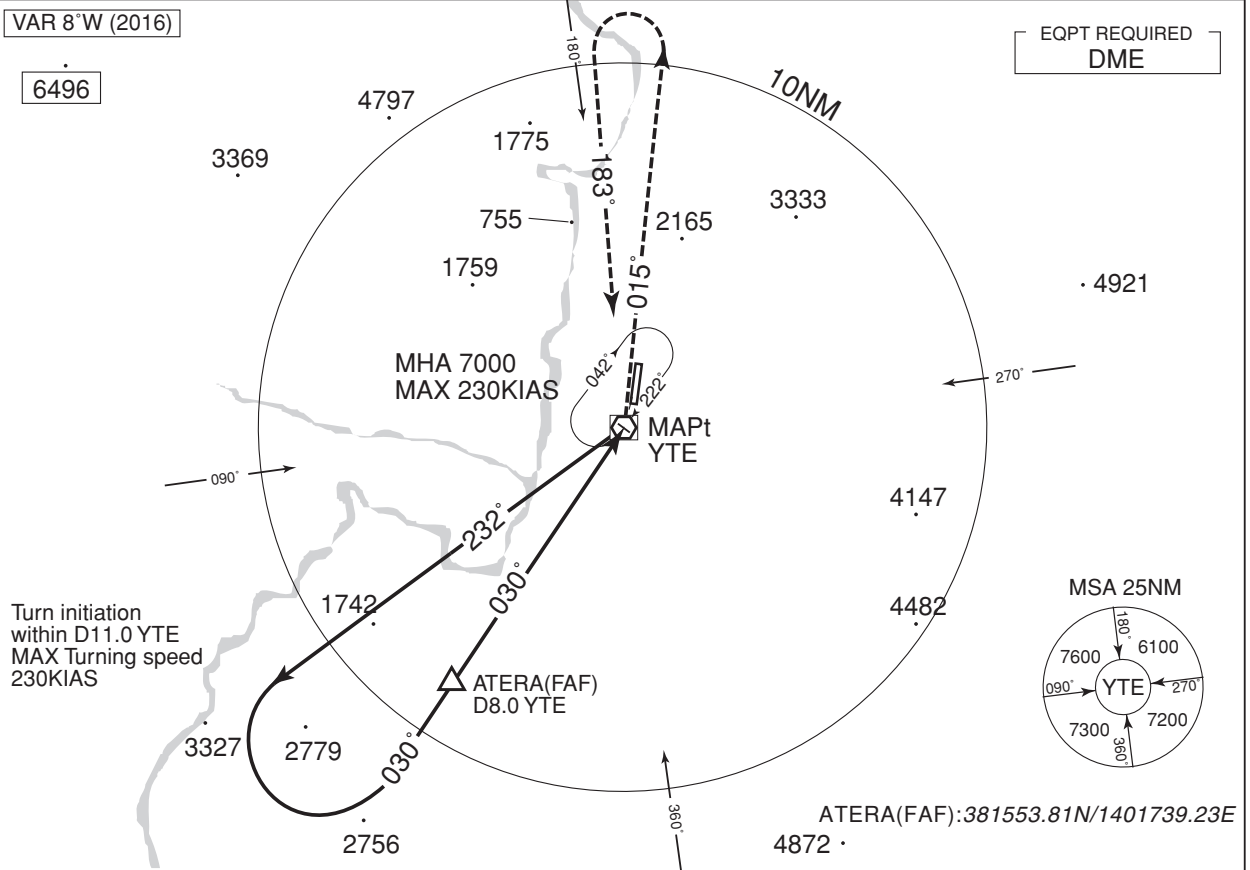

Missed APCH climb gradient MNM 5.0%

MINIMA		AD elev. 345
CAT	CIRCLING	
	MDA(H)	VIS
A	850 (505)	1600
B		2400
C	900 (555)	3200
D		

MINIMA with Missed APCH climb gradient of 2.5% are not established.
Circling to WEST side of RWY only.

CHANGE : MHA

RJSC / YAMAGATA

Visual REP



RJSC / YAMAGATA

Visual REP

Call sign	BRG / DIST from ARP	Remarks
舟形 Funagata	351°T/17.7NM	舟形インターチェンジ Interchange
徳良湖 Tokurako	017°T/11.5NM	徳良湖 Lake
楯岡 Tateoka	010°T/ 4.0NM	村山駅(旧楯岡駅) JR station
碁点 Goten	344°T/ 4.5NM	村山市民体育館 Gymnasium
谷地 Yachi	282°T/ 3.0NM	谷地高校 School
関山峠 Sekiyama Toge	100°T/ 9.5NM	関山トンネル Tunnel
西川 Nishikawa	274°T/ 9.8NM	西川インターチェンジ Interchange
寒河江 Sagae	242°T/ 5.1NM	寒河江駅 JR station
アテラ Atera	203°T/ 9.3NM	山形中央インターチェンジ Interchange
山形ステーション Yamagata Station	192°T/10.0NM	山形駅 JR station
上山 Kaminoyama	196°T/16.2NM	上山温泉駅 JR station

CHANGE : Obanazawa deleted, Funagata, Tokurako added

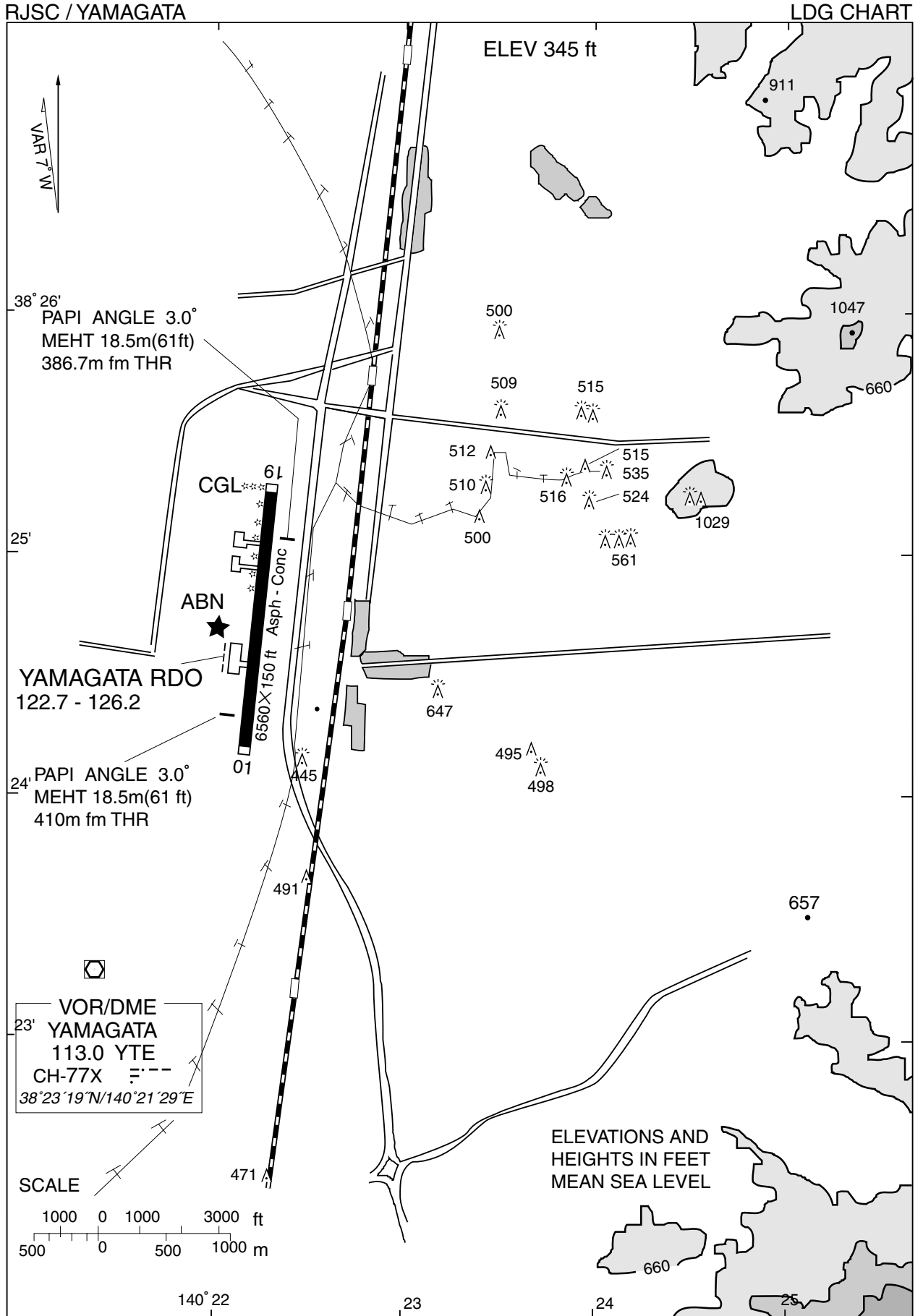

INSTRUMENT APPROACH CHART

RJSC / YAMAGATA

LOC Z RWY01

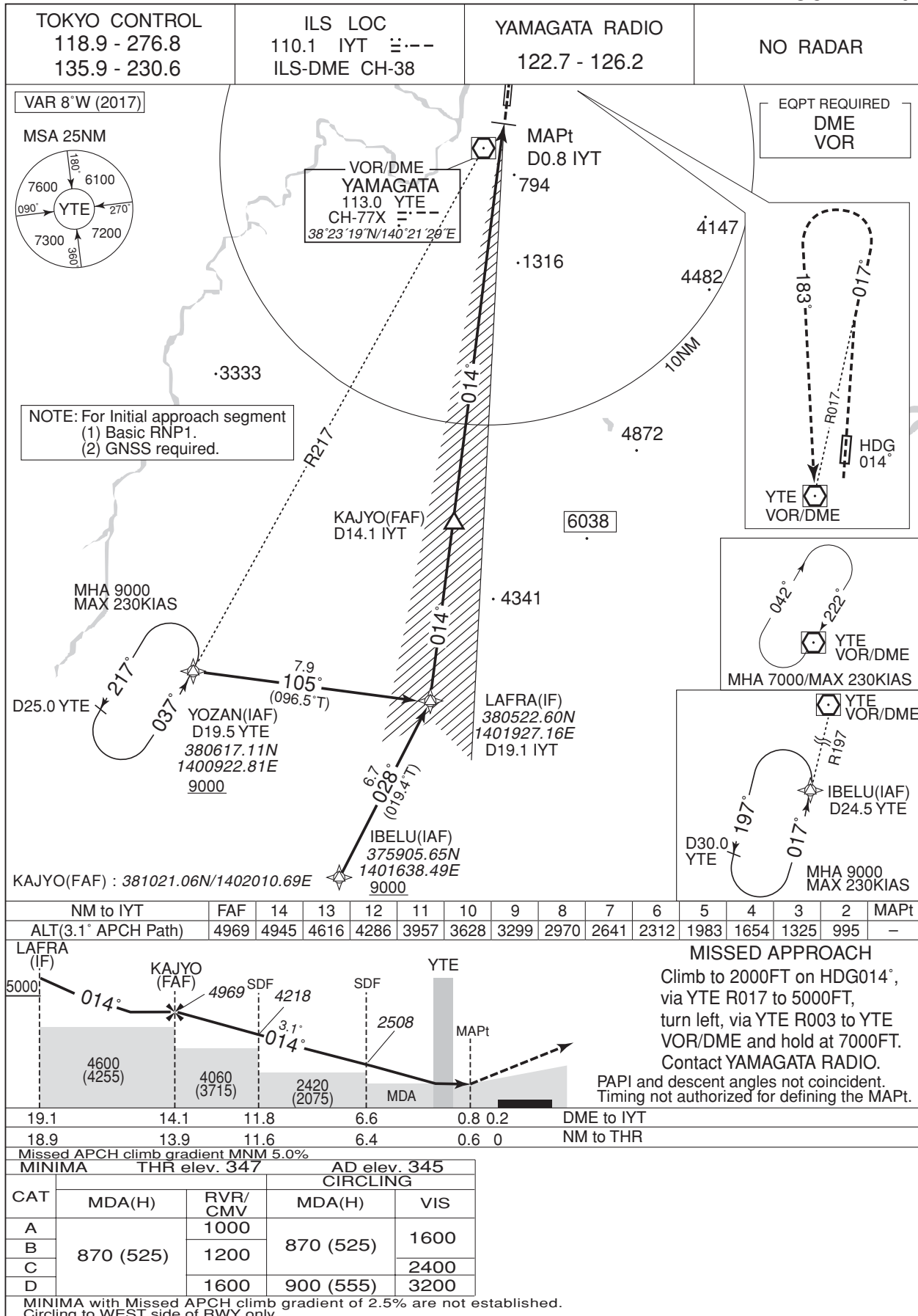

RJSC / YAMAGATA

Minimum Vectoring Altitude CHART

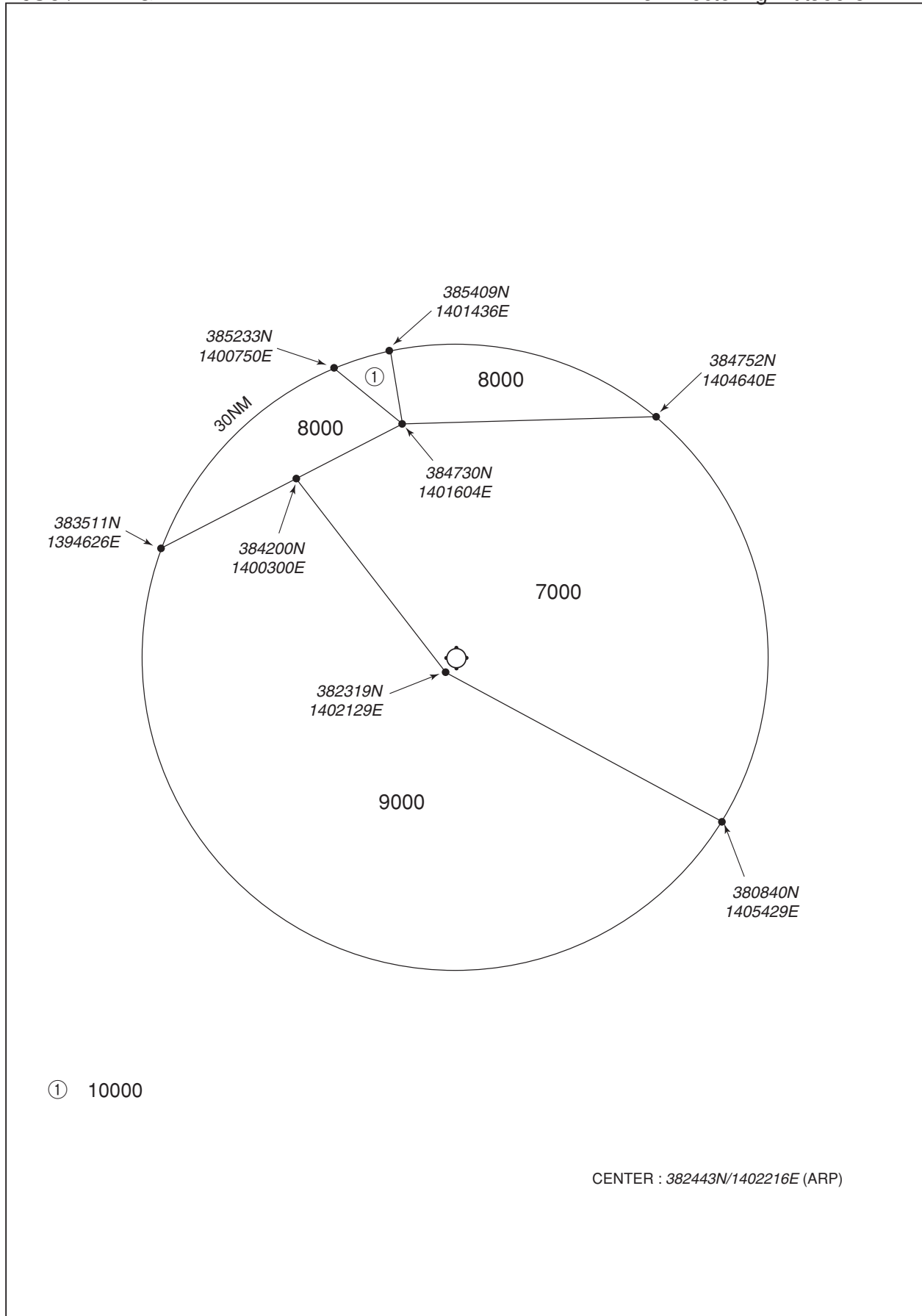

STANDARD DEPARTURE CHART-INSTRUMENT

RJSC / YAMAGATA

RNAV SID

RUBIS ONE DEPARTURE

Basic RNP1

Note GNSS required.

VAR 8°W (2017)

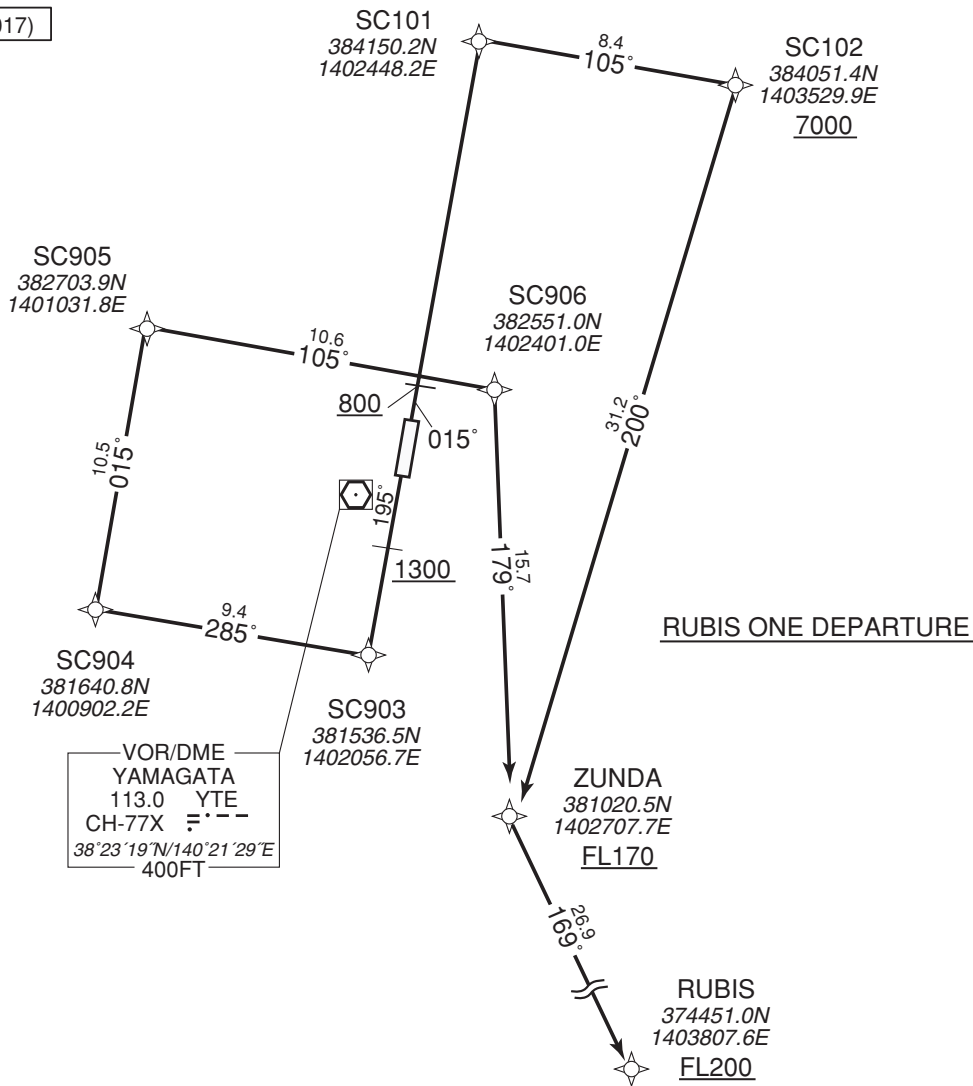

RUBIS ONE DEPARTURE

RWY01 : Climb on HDG015° at or above 800FT, direct to SC101, to SC102 at or above 7000FT,...

RWY19 : Climb on HDG195° at or above 1300FT, direct to SC903, to SC904, to SC905, to SC906,...

... to ZUNDA at or above FL170, to RUBIS at or above FL200.

Note RWY01 : 5.0% climb gradient required up to 2000FT.
 OBST ALT 3609FT located at 16.0NM 039° FM end of RWY01.

RWY19 : 4.0% climb gradient required up to 1300FT.
 OBST ALT 919FT located at 3.2NM 181° FM end of RWY19.

CHANGE : New PROC

STANDARD DEPARTURE CHART-INSTRUMENT

RJSC / YAMAGATA

RNAV SID

RUBIS ONE DEPARTURE

RWY01

Serial Number	Path Descriptor	Waypoint Identifier	Fly Over	Course °M(°T)	Magnetic Variation	Distance (NM)	Turn Direction	Altitude (FT)	Speed (KIAS)	Vertical Angle	Navigation Specification
001	VA	-	-	015 (006.6)	-8.2	-	-	+800	-	-	Basic RNP1
002	DF	SC101	-	-	-8.2	-	-	-	-	-	Basic RNP1
003	TF	SC102	-	105 (096.6)	-8.2	8.4	-	+7000	-	-	Basic RNP1
004	TF	ZUNDA	-	200 (192.2)	-8.2	31.2	-	+FL170	-	-	Basic RNP1
005	TF	RUBIS	-	169 (161.2)	-8.2	26.9	-	+FL200	-	-	Basic RNP1

RWY19

Serial Number	Path Descriptor	Waypoint Identifier	Fly Over	Course °M(°T)	Magnetic Variation	Distance (NM)	Turn Direction	Altitude (FT)	Speed (KIAS)	Vertical Angle	Navigation Specification
001	VA	-	-	195 (186.6)	-8.2	-	-	+1300	-	-	Basic RNP1
002	DF	SC903	-	-	-8.2	-	-	-	-	-	Basic RNP1
003	TF	SC904	-	285 (276.6)	-8.2	9.4	-	-	-	-	Basic RNP1
004	TF	SC905	-	015 (006.4)	-8.2	10.5	-	-	-	-	Basic RNP1
005	TF	SC906	-	105 (096.5)	-8.2	10.6	-	-	-	-	Basic RNP1
006	TF	ZUNDA	-	179 (171.0)	-8.2	15.7	-	+FL170	-	-	Basic RNP1
007	TF	RUBIS	-	169 (161.2)	-8.2	26.9	-	+FL200	-	-	Basic RNP1

CHANGE : New PROC

ILS

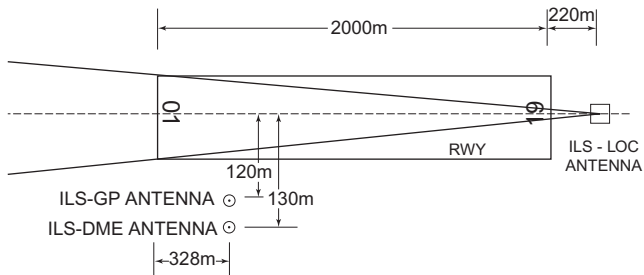

- REMARKS :
- | | |
|-------------------------|---------------|
| 1. LOC beam BRG(MAG) | 014° |
| 2. HGT of ILS REF datum | 16.5m(54ft) |
| 3. GP Angle | 3.0° |
| 4. ELEV of ILS-DME | 110.4m(362ft) |

LOC unusable is the following area : (1) beyond 10° East side of LOC course.
(2) beyond 8° East side of LOC course beyond 17nm from LOC ANT.

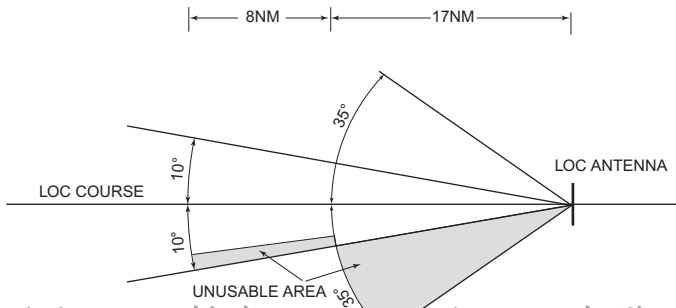

B-767型機の滑走路180° 転回実施要領

1. 滑走路中心線からターニングパッド中心線標識に従って進行する。
2. 転回灯1が一直線に見えるように進行し、転回灯2が一直線に見えた時転回を開始する。転回時はMAX STEERING ANGLEを使用する。

Procedure of 180° turn on RWY for B-767 aircraft

1. Proceed along the RWY Turn Pad Center Line Marking.
2. Proceed along the RWY Turn Pad Center Line Marking to see the Turning Point Indicator Light 1 on a straight line, then commence turn at the spot where you (pilot) can see the Turning Point Indicator Light 2 on a straight line at an angle of 9 o'clock. When turning, take MAX STEERING ANGLE.

YAMAGATA AP

