

## AD 2 AERODROMES

## RJOW AD 2.1 AERODROME LOCATION INDICATOR AND NAME

## RJOW - IWAMI

## RJOW AD 2.2 AERODROME GEOGRAPHICAL AND ADMINISTRATIVE DATA

1	ARP coordinates and site at AD	344035N / 1314725E 105°/1km FM RWY 11 THR
2	Direction and distance from (city)	2.8NM W of MASUDA City
3	Elevation/ Reference temperature	177ft / 30°C(2003-2007)
4	Geoid undulation at AD ELEV PSN	108ft
5	MAG VAR/ Annual change	7°W(2008) / 1.3°W
6	AD Administration, address, telephone, telefax, telex, AFS, e-mail and/or Web-site addresses	Shimane Pref. Public AP Iwami airport administration office. 1597, Uchida-cho, Masuda-city, Shimane, 698-0051 JAPAN Tel : 0856-24-0002 Fax : 0856-23-5491 AFS : Nil E-mail : iwamikukokanri@pref.shimane.lg.jp Web : http://www.pref.shimane.jp/
7	Types of traffic permitted (IFR/VFR)	IFR/VFR
8	Remarks	Nil

## RJOW AD 2.3 OPERATIONAL HOURS

1	AD Administration	2300 - 1030
2	Customs and immigration	On request Customs: 0855-27-0366 Immigration: 0852-21-3834
3	Health and sanitation	Quarantine(human): On request(082-251-1836) Quarantine(animal, plant): Nil
4	AIS Briefing Office	Nil
5	ATS Reporting Office(ARO)	Nil
6	MET Briefing Office	H24 (KANSAI)
7	ATS	2300 - 1030 Remarks : Airport remote mobile communication service provided by Osaka FSC
8	Fuelling	2300 - 1030
9	Handling	2300 - 1030
10	Security	2300 - 1030
11	De-icing	2300 - 1030
12	Remarks	Nil

**RJOW AD 2.4 HANDLING SERVICES AND FACILITIES**

1	Cargo-handling facilities	All the modern institutions that deal with the aircraft to B737-500
2	Fuel/ oil types	Fuel grades : JET-A-1 Oil grades : Nil
3	Fuelling facilities/ capacity	Fuel truck refueling / Not limitation
4	De-icing facilities	TYPE-4 ABC-S, TYPE-1 DF-PLUS
5	Hangar space for visiting aircraft	Nil
6	Repair facilities for visiting aircraft	Nil
7	Remarks	Nil

**RJOW AD 2.5 PASSENGER FACILITIES**

1	Hotels	In Masuda city
2	Restaurants	At airport
3	Transportation	Busses and taxis
4	Medical facilities	In Masuda city 5km
5	Bank and Post Office	Nil
6	Tourist Office	Nil
7	Remarks	Nil

**RJOW AD 2.6 RESCUE AND FIRE FIGHTING SERVICES**

1	AD category for fire fighting	CAT 7
2	Rescue equipment	Chemical fire fighting truck x 2, Emergency medical equipments conveyance truck x 1
3	Capability for removal of disabled aircraft	Ask AD administration
4	Remarks	Nil

**RJOW AD 2.7 SEASONAL AVAILABILITY-CLEARING**

1	Types of clearing equipment	Snow plow x 2, Snow sweeper x 1, Rotary x 1
2	Clearance priorities	(1) RWY 11/29 (2)TWY, Apron
3	Remarks	Nil

**RJOW AD 2.8 APRONS, TAXIWAYS AND CHECK LOCATIONS DATA**

1	Apron surface and strength	Surface : cement-concrete, Strength : PCN 53/R/C/X/T
2	Taxiway width, surface and strength	Width:30m, Surface : asphalt-concrete, Strength:PCN 58/F/C/X/T
3	ACL and elevation	Not available
4	VOR checkpoints	Not available
5	INS checkpoints	Spot NR 1: 344041.11N 1314746.35E 2: 344040.68N 1314748.34E 3: 344040.18N 1314750.62E
6	Remarks	Nil

**RJOW AD 2.9 SURFACE MOVEMENT GUIDANCE AND CONTROL SYSTEM AND MARKINGS**

1	Use of aircraft stand ID signs, TWY guide lines and Visual docking/ parking guidance system of aircraft stands	Nil
2	RWY and TWY markings and LGT	RWY:11/29 (Marking) RWY designation, RWY CL, RWY THR, RWY middle point, Aiming point, TDZ, RWY side stripe, RWY turn pad edge, RWY turn pad CL, RWY turn pad aiming (LGT)RCLL, REDL, RTHL, RENL, RTZL(RWY11), WBAR(RWY11), Turning point indicator LGT  TWY: (Marking)TWY CL, TWY side stripe, RWY HLDG PSN (LGT)TWY edge LGT, TWY CL
3	Stop bars	Nil
4	Remarks	(Marking) Overrun area (LGT) APN flood LGT

RWY Turn pads are installed as shown in below figure, and procedures for 180° turn on RWY is established for RWY 11 and 29 as follows:

- a. Proceed along the RWY Center Line to the starting point of the RWY Turn Pad Center Line Marking; then,
- b. proceed along the RWY Turn Pad Center Line Marking to see the Turning Point Indicator Lights 1 on a straight line, then commence turn at the spot where you (pilot) can see the Turning Point Indicator Lights 2 on a straight line at an angle of 9 o'clock. When turning, take MAX STEERING ANGLE.

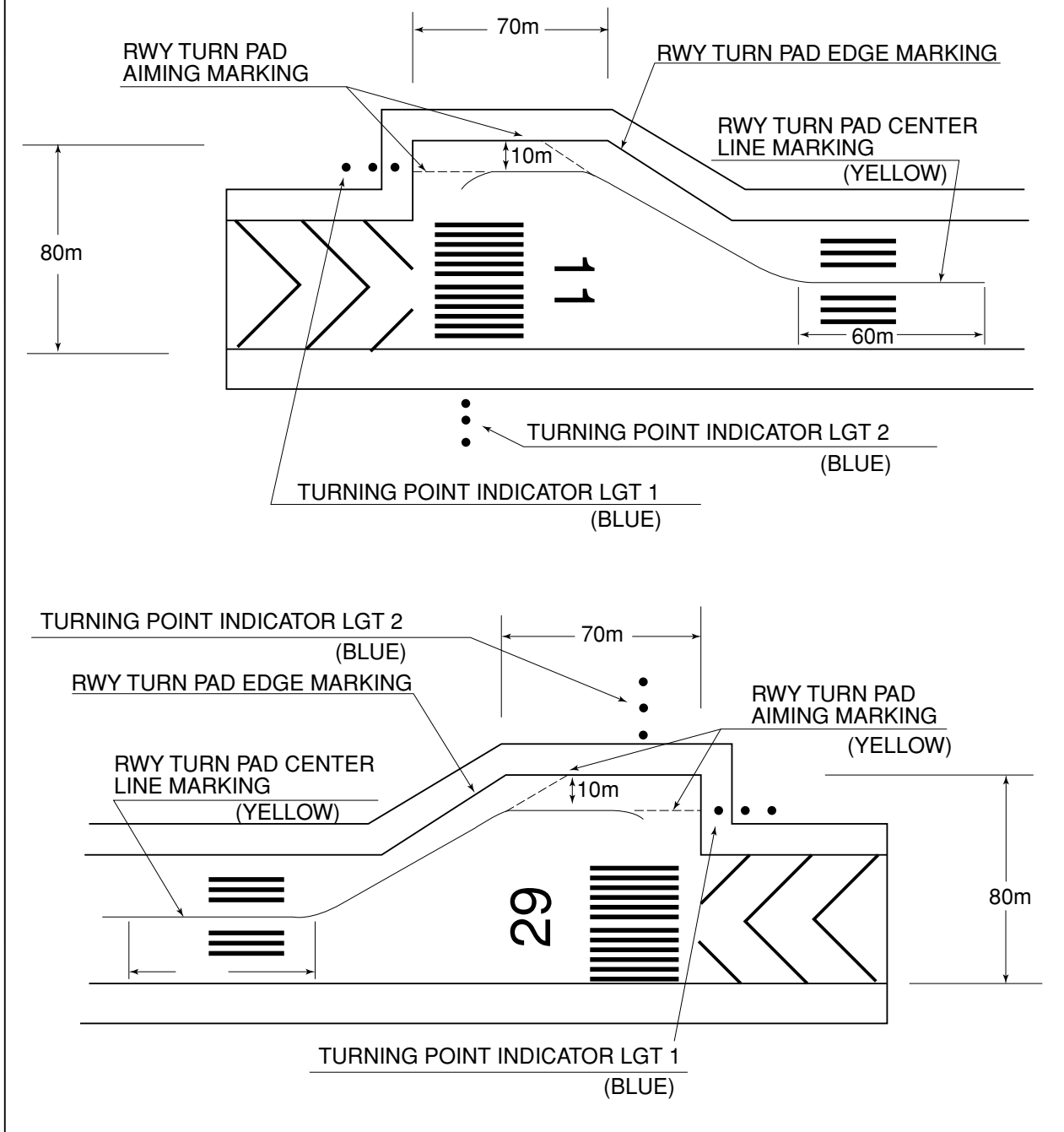

**RJOW AD 2.10 AERODROME OBSTACLES**

See AD2.24 chart

In approach/TKOF areas

RWY/Area affected	Obstacle type	Coordinates	Elevation	Markings / LGT	Remarks
Nil					

In circling area and at AD

Obstacle type	Coordinates	Elevation	Markings / LGT	Remarks
Panzer mast	343955.5N/1314634.1E	314ft	- / LIM (Red)	Obstacle near the horizontal surface
Panzer mast	343921.5N/1314637.1E	361ft	- / LIM (Red)	Obstacle above the horizontal surface
Panzer mast	343923.5N/1314739.1E	319ft	- / LIM (Red)	Obstacle near the horizontal surface
Panzer mast	343929.5N/1314850.1E	319ft	- / LIL (Red)	Obstacle near the horizontal surface

**RJOW AD 2.11 METEOROLOGICAL INFORMATION PROVIDED**

1	Associated MET Office	KANSAI
2	Hours of service MET Office outside hours	H24 (KANSAI)
3	Office responsible for TAF preparation Periods of validity	Nil
4	Trend forecast Interval of issuance	Nil
5	Briefing/ consultation provided	Briefing is available upon inquiry at KANSAI
6	Flight documentation Language(s) used	C En
7	Charts and other information available for briefing or consultation	S <sub>6</sub> , U <sub>85</sub> , U <sub>7</sub> , U <sub>5</sub> , U <sub>3</sub> , U <sub>25</sub> , U <sub>2</sub> /T <sub>r</sub> , P <sub>S</sub> , P <sub>5</sub> , P <sub>3</sub> , P <sub>25</sub> , P <sub>SWE</sub> , P <sub>SWF</sub> , P <sub>SWG</sub> , P <sub>SWI</sub> , P <sub>SWM</sub> , P <sub>SW</sub> (domestic), E, C, W <sub>E</sub> , W <sub>F</sub> , W <sub>G</sub> , W <sub>I</sub> , W, N
8	Supplementary equipment available for providing information	Nil
9	ATS units provided with information	REMOTE
10	Additional information(limitation of service, etc.)	Nil

## RJOW AD 2.12 RUNWAY PHYSICAL CHARACTERISTICS

Designations RWY NR	TRUE BRG	Dimensions of RWY(M)	Strength(PCN) and surface of RWY	THR coordinates THR geoid undulation	THR elevation and highest elevation of TDZ of precision APP RWY
1	2	3	4	5	6
11	104.78°	2000×45	PCN 42/F/A/X/T Asphalt Concret	344043.28N 1314647.11E 108.2ft	THR ELEV : 183.7ft TDZ ELEV : 182.8ft
29	284.78°	2000×45	PCN 42/F/A/X/T Asphalt Concrete	344026.72N 1314803.07E 108.3ft	THR ELEV : 170.6ft

Slope of RWY	Strip Dimensions(M)	RESA (Overrun) Dimensions(M)	Remarks
7	10	11	14
SEE AD2.24 AD chart	2120×300 2120×300	190 × (MNM:160 MAX:300)* 40 × (MNM:272 MAX:300)*	RWY Grooving : 2000m×30m
*For detail, ask airport administrator			

## RJOW AD 2.13 DECLARED DISTANCES

RWY Designator	TORA (m)	TODA (m)	ASDA (m)	LDA (m)	Remarks
1	2	3	4	5	6
11	2000	2000	2000	2000	Nil
29	2000	2000	2000	2000	Nil

## RJOW AD 2.14 APPROACH AND RUNWAY LIGHTING

RWY Designator	APCH LGT type LEN INTST	RTHL Color WBAR	PAPI (VASIS) Angle DIST FM THR MEHT	RTZL LEN	RCLL LEN Spacing Color INTST	REDL LEN Spacing Color INTST	RENL Color WBAR	STWL LEN Color
1	2	3	4	5	6	7	8	9
11	PALS (CAT I) 900m LIH	Green Green	PAPI 3.0°/Left 402.2m 61ft	900m	2000m 30m Coded color (White/Red) LIH	2000m 60m Coded color (White/Yellow) LIH	Red	Nil (*2)
29	SALS (*1) 420m LIH	Green -	PAPI 3.0°/Left 362.0m 61ft	-	2000m 30m Coded color (White/Red) LIH	2000m 60m Coded color (White/Yellow) LIH	Red	Nil (*2)
Remarks								
10								
SALS with APCH LGT beacon (585m and 852m FM RWY 29 THR ) (*1) Overrun area edge LGT(LEN:60m Color:Red)(*2) CGL for RWY 29								

**RJOW AD 2.15 OTHER LIGHTING, SECONDARY POWER SUPPLY**

1	ABN/IBN location, characteristics and hours of operation	ABN: 344049N/1314751E, White/Green EV4.3sec, HO
2	LDI location and LGT Anemometer location and LGT	LDI : Nil Anemometer : RWY 11 : 330m FM RWY 11 THR, LGTD RWY 29 : 260m FM RWY 29 THR, LGTD
3	TWY edge and center line lighting	TWY edge LGT: Blue TWY CL LGT: ALTN Green/Yelow FM RWY leaving Report point, other Green
4	Secondary power supply / switch-over time	Within 1sec : REDL, RTHL, RENL, WBAR, RCLL, Overrun area edge LGT, Turnig point indicator LGT Within 15sec : Other LGT
5	Remarks	WDI LGT

**RJOW AD 2.16 HELICOPTER LANDING AREA**

Nil
-----

**RJOW AD 2.17 ATS AIRSPACE**

Designation and lateral limits		Vertical limits (ft)	Airspace classification	ATS unit call sign Language	Remarks
1		2	3	4	6
Iwami Information Zone	Area within a radius of 5nm(9km)of Iwami ARP	3,000	E	Iwami Remote En	

**RJOW AD 2.18 ATS COMMUNICATION FACILITIES**

Service designation	Call sign	Frequency	Hours of operation	Remarks
1	2	3	4	5
A/G	Iwami Remote	122.2MHz	2300 - 1030	Remoto air-ground facilities controlled by Osaka FSC

## RJOW AD 2.19 RADIO NAVIGATION AND LANDING AIDS

表 1 :

Type of aid (VOR declination)	ID	Frequency	Hours of operation	Position of transmitting antenna coordinates	Elevation of DME transmitting antenna	Remarks
1	2	3	4	5	6	7
VOR (7°W/ 2008)	IME	115.05MHz	2300- 1030	344034.48N 1314647.57E		
DME	IME	1058 MHz (CH-97Y)	2300- 1030	344034.48N 1314647.57E	228ft	
ILS-LOC 11	IWA	108.1MHz	2300- 1030	344024.80N 1314812.02E		LOC : 235m away FM RWY 29 THR, BRG (MAG) 112° LOC unusable : beyond 20° south(150Hz) side of LOC course.
ILS-GP 11	-	334.7MHz	2300- 1030	344044.37N 1314700.71E		GP : 327m inside FM RWY 11 THR, 120m N of RCL. HGT of ILS Ref datum 16.5m (54ft) GP angle 3.0. GP unusable : beyond 5° north(90Hz) side of LOC course.
ILS-DME 11	IWA	979 MHz (CH-18X)	2300- 1030	344044.68N 1314700.85E	194ft	DME : 327m inside FM RWY 11THR, 130m N of RCL.
MSAS		1575.42MHz	H24			Transmitting antennas are satellite based.



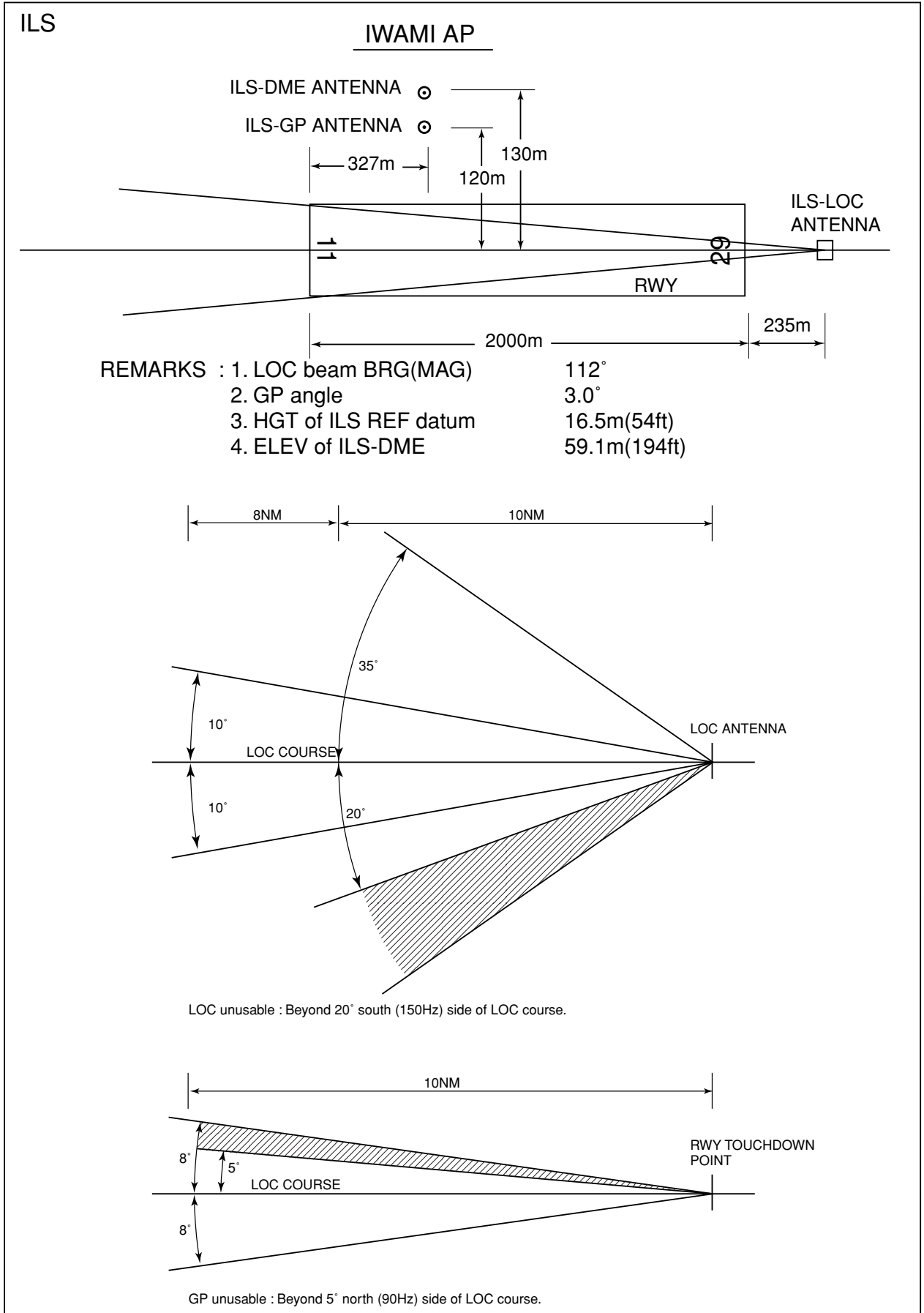

**RJOW AD 2.20 LOCAL TRAFFIC REGULATIONS**

## 1. Airport regulations

On use of Iwami airport, aircraft operator is required to notify Shimane Pref in advance.

## 2. Taxiing to and from stands

Nil

## 3. Parking area for small aircraft (General aviation)

Nil

## 4. Parking area for helicopters

Nil

## 5. Apron - taxiing during winter conditions

Nil

## 6. Taxiing - limitations

Nil

## 7. School and training flights - technical test flights - use of runways

Nil

## 8. Helicopter traffic - limitation

Nil

## 9. Removal of disabled aircraft from runways

Nil

**RJOW AD 2.21 NOISE ABATEMENT PROCEDURES**

Ask AD administration

**RJOW AD 2.22 FLIGHT PROCEDURES**

**TAKE OFF MINIMA**

	RWY	REDL & RCLL		REDL or RCLL or RCL Marking		NIL (DAY ONLY)	
		RVR	VIS	RVR	VIS	RVR	VIS
Multi-Engine ACFT with TKOF ALTN AP Filed	11	400m	400m	400m	400m	-	500m
	29	-	400m	-	400m	-	500m
OTHER	11	AVBL LDG MINIMA					
	29						

**RJOW AD 2.23 ADDITIONAL INFORMATION**

Ask AD administration

**RJOW AD 2.24 CHARTS RELATED TO AN AERODROME**

- Aerodrome/Heliport Chart
- Standard Departure Chart - Instrument (SAMBA)
- Standard Departure Chart - Instrument (RNAV TRANSITION)
- Instrument Approach Chart (ILS or LOC RWY11)
- Instrument Approach Chart (VOR RWY11)
- Instrument Approach Chart (VOR A)
- Instrument Approach Chart (RNAV(RNP)RWY11)
- Instrument Approach Chart (RNAV(RNP)RWY29)
- Other Chart (Visual REP)
- Other Chart(LDG CHART)
- Other Chart(MVA CHART)

**INTENTIONALLY LEFT BLANK**

RJOW / IWAMI

AD CHART

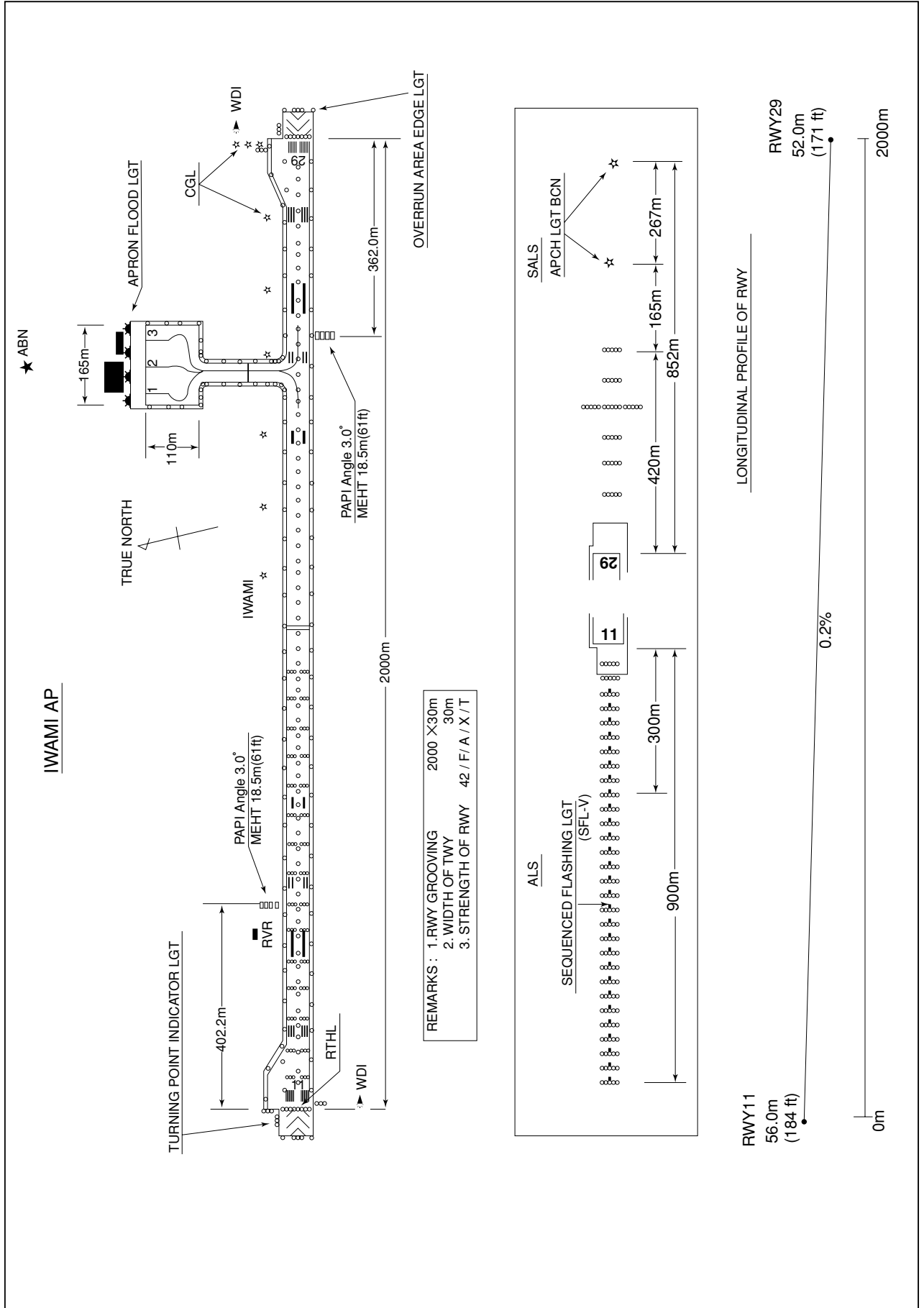

INSTRUMENT APPROACH CHART

RJOW / IWAMI

RNAV(RNP) RWY11

KOBE CONTROL 132.5 - 246.1 134.25 - 315.5	GNSS and RF required.	IWAMI REMOTE 122.2	NO RADAR
---	-----------------------	-----------------------	----------

For uncompensated Baro-VNAV systems, procedure not authorized below -5 °C / above 45°C

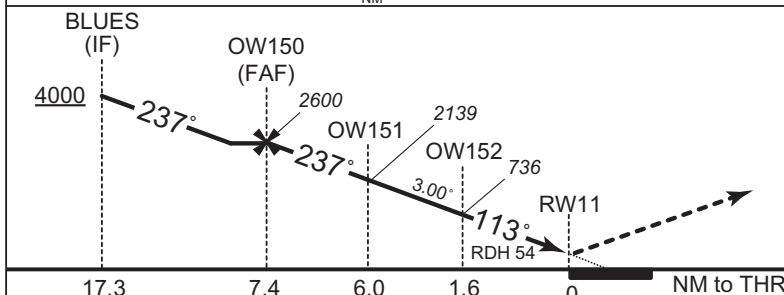
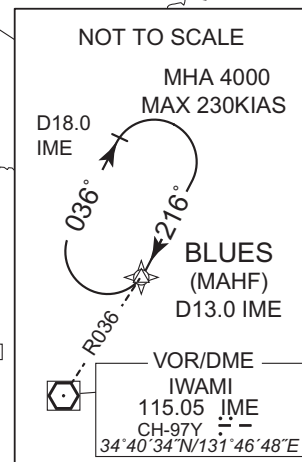
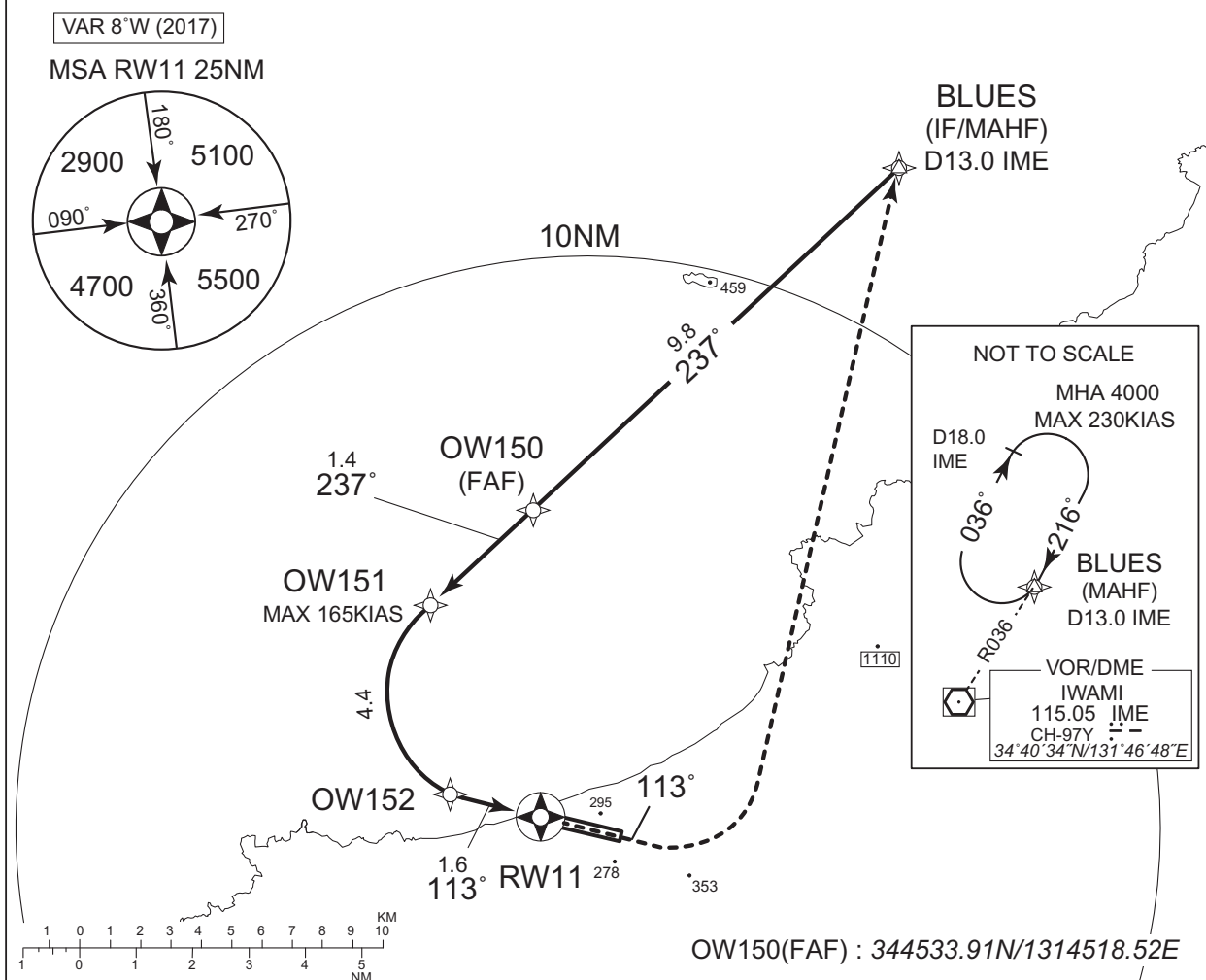

**MISSED APPROACH**  
From RW11 on track 113°, at or above 600FT turn left, direct to BLUES and hold at 4000FT.  
Contact IWAMI REMOTE.

CHANGE: ATC call sign.

Missed APCH climb gradient MNM 5.0%

MINIMA	THR elev. 184	AD elev. 177
RNP 0.30		
CAT	DA(H)	RVR/CMV
A	-	-
B	-	-
C	484(300)	1000
D	-	-

**RNP AR**  
Special Authorization Required

MINIMA with Missed APCH climb gradient of 2.5% are not established.

INSTRUMENT APPROACH CHART

RJOW / IWAMI

➔ RNAV(RNP) RWY11

RNAV(RNP) RWY11

Coding Table

Serial Number	Path Descriptor	Waypoint Identifier	Fly Over	course °M(°T)	Magnetic Variation	Distance (NM)	Turn Direction	Altitude (FT)	Speed (KIAS)	VPA/RDH (°/FT)	RNP Value
001	IF	BLUES	-	-	-7.8	-	-	+4000	-	-	1.0
002	TF	OW150	-	237 (229.3)	-7.8	9.8	-	2600	-	-	1.0
003	TF	OW151	-	237 (229.2)	-7.8	1.4	-	2139	-165	-3.00	0.3
004	RF Center: OWRF1 r=2.03NM	OW152	-	-	-7.8	4.4	L	736	-	-3.00	0.3
005	TF	RW11	Y	113 (104.8)	-7.8	1.6	-	238	-	-3.00/54	0.3
006	FA	-	-	113 (104.8)	-7.8	-	-	+600	-	-	1.0
007	DF	BLUES	-	-	-7.8	-	L	4000	-	-	1.0

Waypoint Coordinates

Waypoint Identifier	Coordinates	RF Arc Center Identifier	Coordinates
BLUES	345159.02N/1315423.09E	OWRF1	344304.90N/1314534.53E
OW150	344533.91N/1314518.52E		
OW151	344437.18N/1314358.51E		
OW152	344107.26N/1314456.99E		
RW11	344043.28N/1314647.11E		

CHANGE : New PROC

INSTRUMENT APPROACH CHART

RJOW / IWAMI

RNAV(RNP) RWY29

KOBE CONTROL 132.5 - 246.1 134.25 - 315.5	GNSS and RF required.	IWAMI REMOTE 122.2	NO RADAR
---	-----------------------	-----------------------	----------

For uncompensated Baro-VNAV systems, procedure not authorized below -5 °C / above 39°C

VAR 8°W (2017)

MSA RW29 25NM

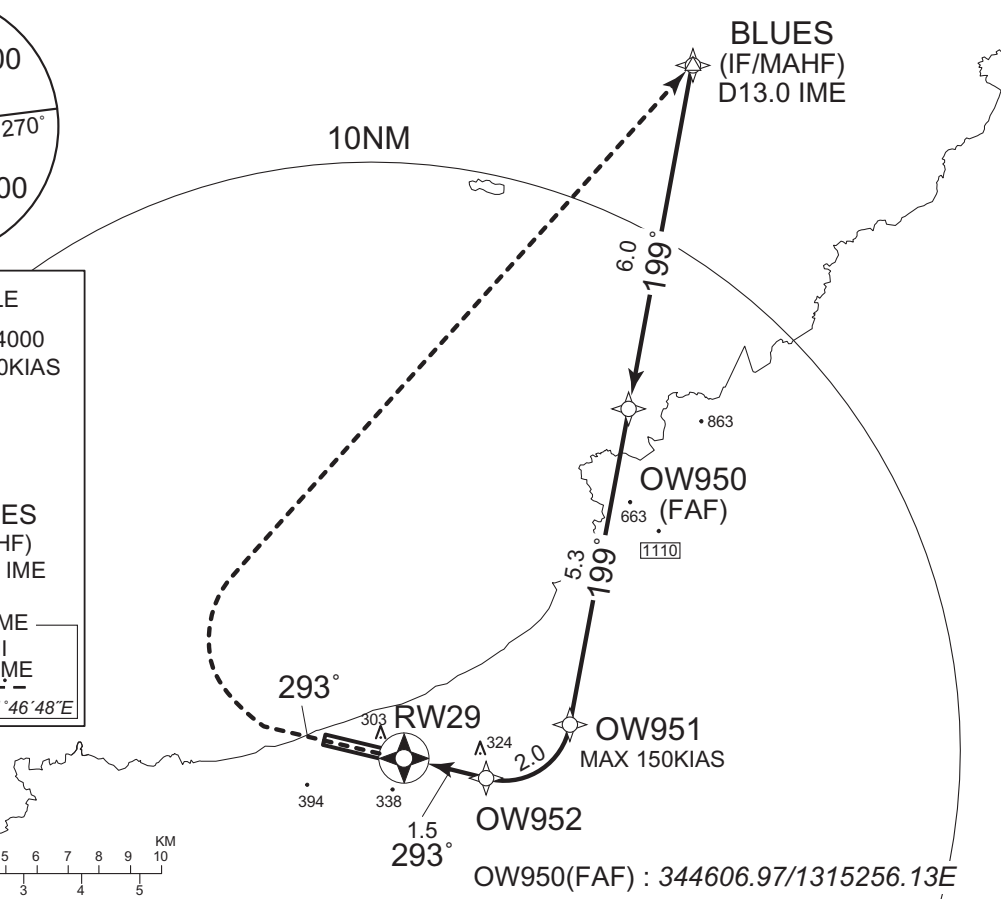
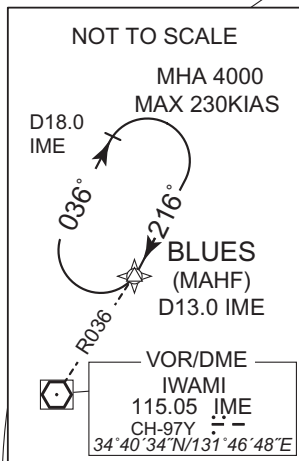
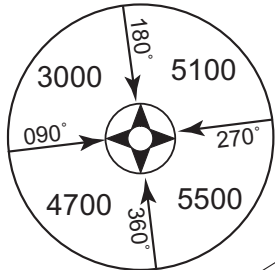

MISSED APPROACH

From RW29 on track 293°, at or above 600FT turn right, direct to BLUES and hold at 4000FT.

Contact IWAMI REMOTE.  
PAPI not coincident with VPA.

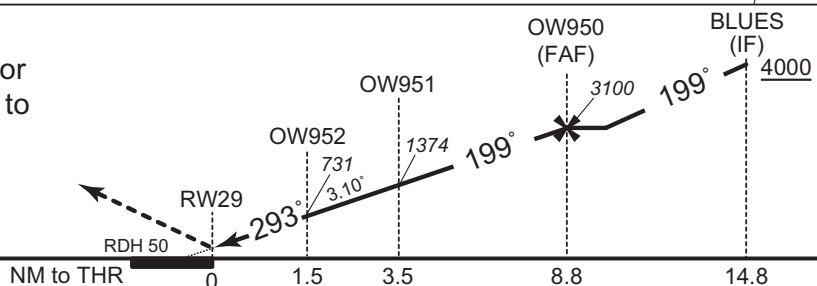

Missed APCH climb gradient MNM 4.0%

MINIMA THR elev. 171 AD elev. 177

CAT	RNP 0.16		RNP 0.30	
	DA(H)	CMV	DA(H)	CMV
A	-	-	-	-
B	-	-	-	-
C	471(300)	1400	489(318)	1400
D	-	-	-	-

**RNP AR**  
Special Authorization Required

MINIMA with Missed APCH climb gradient of 2.5% are not established.

CHANGE: ATC call sign.



INSTRUMENT APPROACH CHART

RJOW / IWAMI

➔ RNAV(RNP) RWY29

RNAV(RNP) RWY29

Coding Table

Serial Number	Path Descriptor	Waypoint Identifier	Fly Over	course °M(^T)	Magnetic Variation	Distance (NM)	Turn Direction	Altitude (FT)	Speed (KIAS)	VPA/RDH (°/FT)	RNP Value
001	IF	BLUES	-	-	-7.8	-	-	+4000	-	-	1.0
002	TF	OW950	-	199 (191.5)	-7.8	6.0	-	3100	-	-	1.0
003	TF	OW951	-	199 (191.5)	-7.8	5.3	-	1374	-150	-3.10	0.16 0.3
004	RF Center: OWRF2 r=1.20NM	OW952	-	-	-7.8	2.0	R	731	-	-3.10	0.16 0.3
005	TF	RW29	Y	293 (284.9)	-7.8	1.5	-	221	-	-3.10/50	0.16 0.3
006	FA	-	-	293 (284.9)	-7.8	-	-	+600	-	-	1.0
007	DF	BLUES	-	-	-7.8	-	R	4000	-	-	1.0

Waypoint Coordinates

Waypoint Identifier	Coordinates	RF Arc Center Identifier	Coordinates
BLUES	345159.02N/1315423.09E	OWRF2	344112.62N/1315014.52E
OW950	344606.97N/1315256.13E		
OW951	344058.27N/1315140.08E		
OW952	344002.90N/1314952.21E		
RW29	344026.72N/1314803.07E		

CHANGE : New PROC

STANDARD DEPARTURE CHART-INSTRUMENT

RJOW / IWAMI

SID and TRANSITION

SAMBA TWO DEPARTURE

RWY11 : Climb RWY HDG to 800FT, turn left HDG351°, ...  
 RWY29 : Climb RWY HDG to 700FT, turn right HDG081°, ...  
 ...to intercept and proceed via IME R036 to SAMBA.  
 Cross SAMBA at or above 7000FT.

Note RWY11 : 5.7% climb gradient required up to 1700FT.  
 OBST ALT 1177FT located at 4.83NM 093° FM end of RWY11.

IZUMO TRANSITION

From over SAMBA, via XZE R252 to XZE VOR/DME.  
 Cross CARNY at or below 13000FT, cross BAARU at or below FL230.

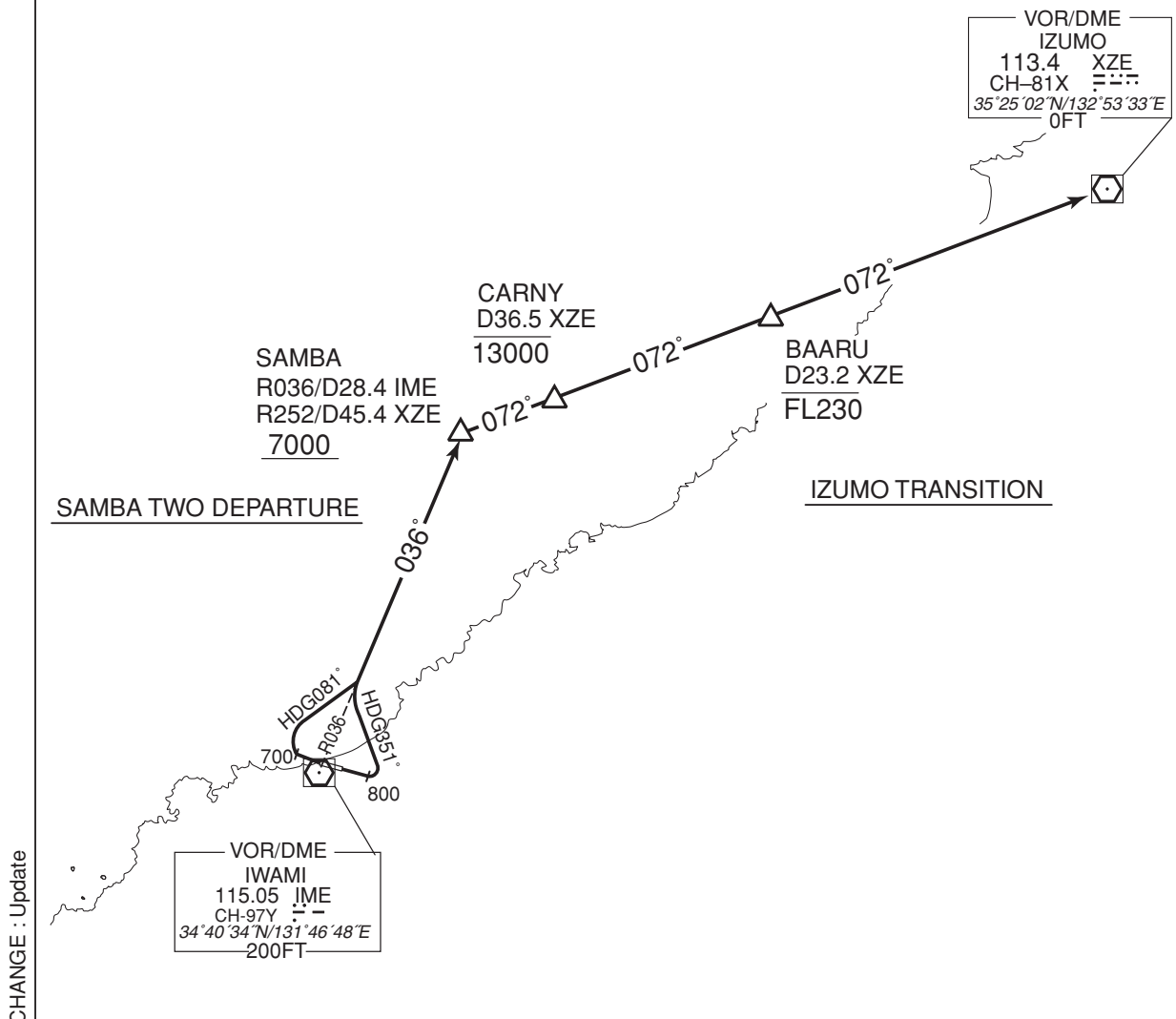

STANDARD DEPARTURE CHART-INSTRUMENT

RJOW / IWAMI

➔ RNAV TRANSITION

VIBEL TRANSITION	RNAV1
------------------	-------

Note 1) DME/DME/IRU or GNSS required.  
2) RADAR service required.

VAR 8°W (2017)

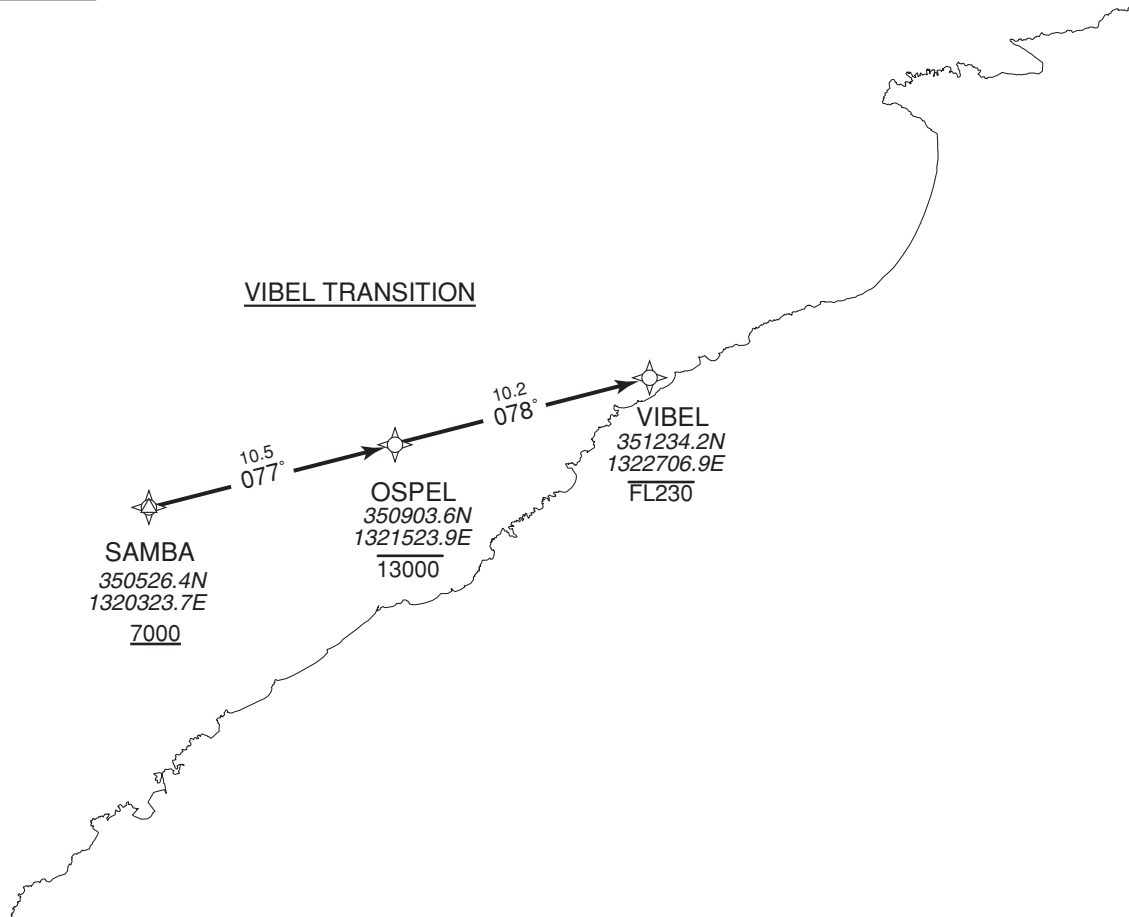

VIBEL TRANSITION

From SAMBA at or above 7000FT, to OSPEL at or below 13000FT, to VIBEL at or below FL230.

Critical DME	STD : SAMBA – VIBEL
DME GAP	-
Inappropriate Navaids	See AD1.1.6.10.3. Inappropriate NAVAIDs for RNAV1.

Serial Number	Path Descriptor	Waypoint Identifier	Fly Over	Course °M(°T)	Magnetic Variation	Distance (NM)	Turn Direction	Altitude (FT)	Speed (KIAS)	Vertical Angle	Navigation Specification
001	IF	SAMBA	-	-	-7.8	-	-	+7000	-	-	RNAV1
002	TF	OSPEL	-	077 (069.7)	-7.8	10.5	-	-13000	-	-	RNAV1
003	TF	VIBEL	-	078 (069.8)	-7.8	10.2	-	-FL230	-	-	RNAV1

CHANGE : New PROC

INSTRUMENT APPROACH CHART

RJOW / IWAMI ILS or LOC RWY11

KOBE CONTROL 132.5-246.1 134.25-315.5	ILS-LOC IWA 108.1 ILS-GP 334.7 ILS-DME CH-18X	IWAMI REMOTE 122.2	NO RADAR
---	---	-----------------------	----------

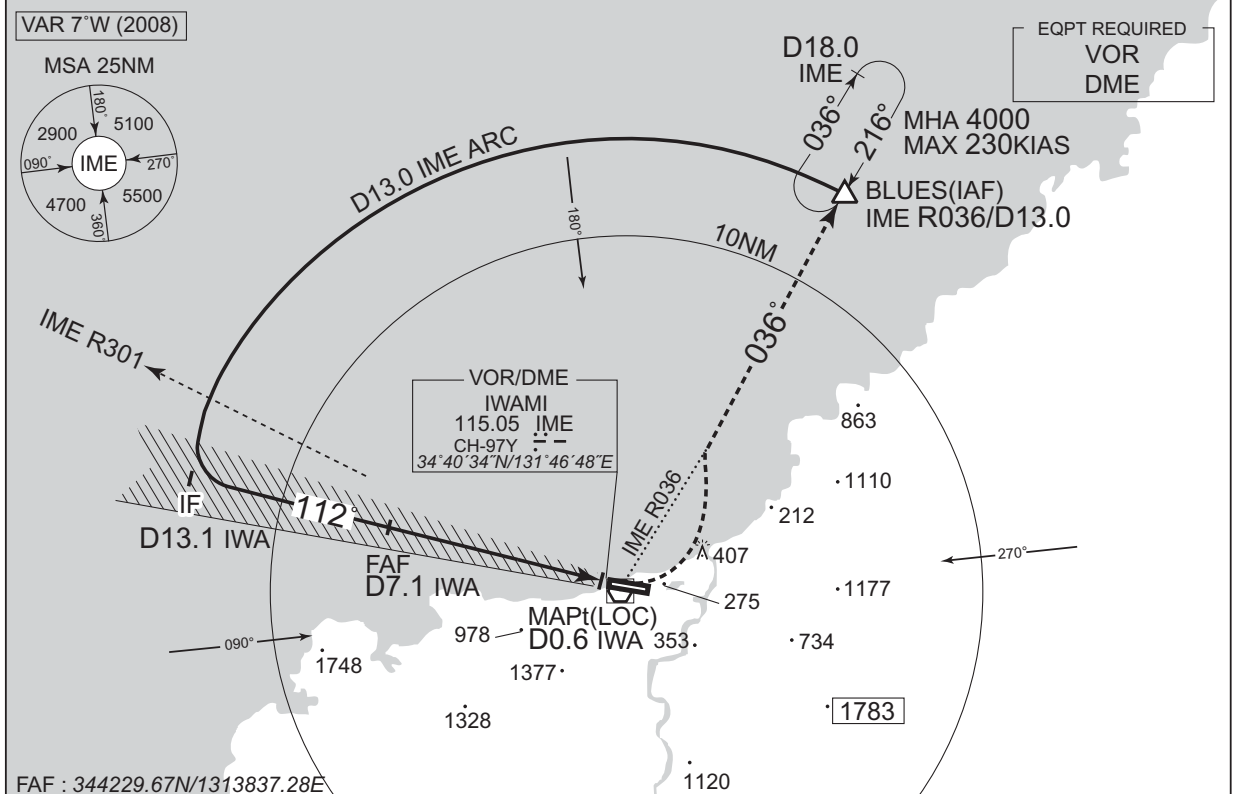

NM to IWA	FAF	7	6	5	4	3	2	1	MAPt
ALT (3.0° APCH Path)	2451	2407	2088	1770	1451	1133	814	495	-

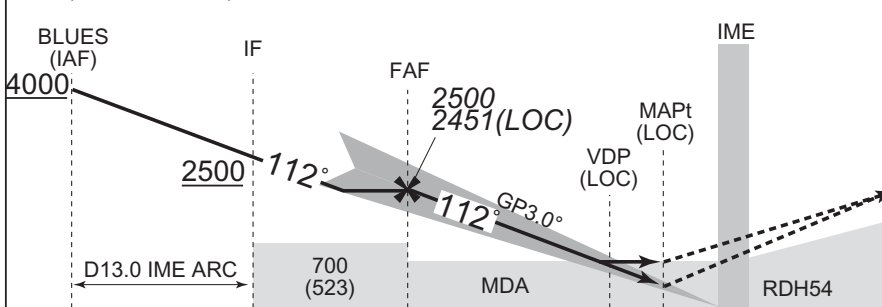

**MISSED APPROACH**  
Turn left, climb to 4000FT via IME R036 to BLUES and hold.  
Contact IWAMI REMOTE.  
  
Timing not authorized for defining the MAPt.

DME to IWA	13.1	7.1	1.0	0.6
NM to THR	13.0	7.0	0.8	0.5

Missed APCH climb gradient MNM 4.0%

MINIMA THR elev. 184 AD elev. 177

CAT	CAT I		LOC		CIRCLING	
	DA(H)	RVR/CMV	MDA(H)	RVR/CMV	MDA(H)	VIS
A	384 (200)	550	480 (303)	900	1000 (823)	1600
B				1000	1100 (923)	
C				1000	1400 (1223)	2400
D				1400	1600 (1423)	3200

Circling to NORTH side of RWY only.  
MINIMA with Missed APCH climb gradient of 2.5% are not established.

INSTRUMENT APPROACH CHART

RJOW / IWAMI

VOR RWY11

KOBE CONTROL 132.5-246.1 134.25-315.5	IWAMI VOR/DME 115.05 IME CH-97Y 34°40'34"N/131°46'48"E	IWAMI REMOTE 122.2	NO RADAR
---	---	-----------------------	----------

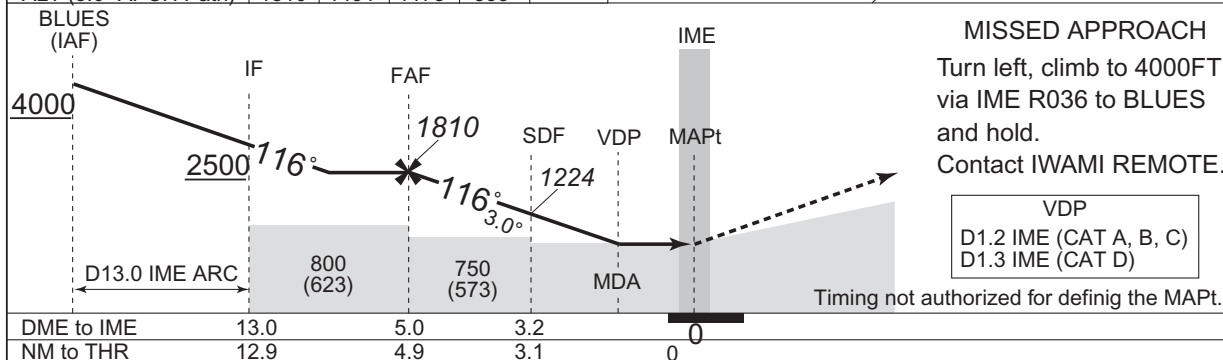
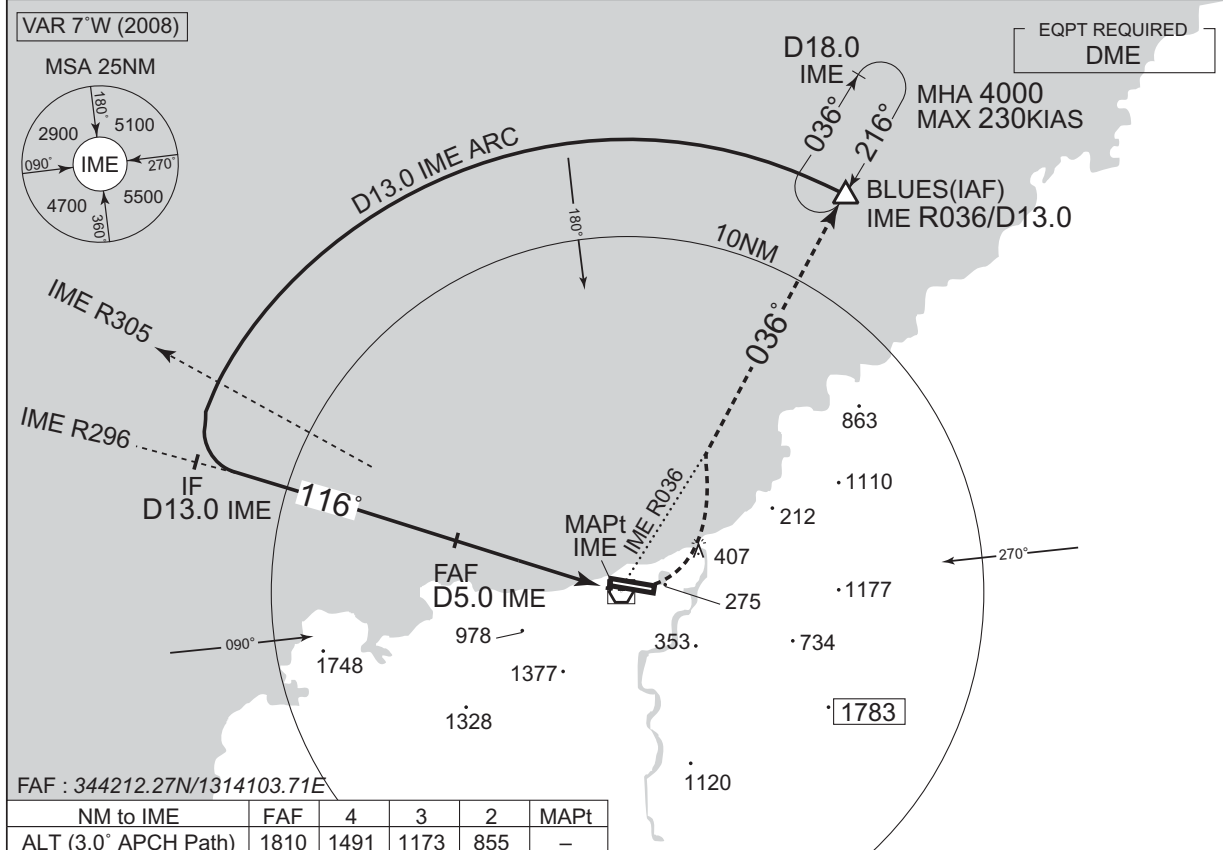

MINIMA		THR elev. 184	AD elev. 177	
CAT	CIRCLING			
	MDA(H)	RVR/CMV	MDA(H)	VIS
A	590 (413)	900	1000 (823)	1600
B		1000	1100 (923)	
C			1400 (1223)	2400
D	610 (433)	1400	1600 (1423)	3200

Circling to NORTH side of RWY only

CHANGE: ATC call sign.

INSTRUMENT APPROACH CHART

RJOW / IWAMI

VOR A

KOBE CONTROL 132.5 - 246.1 134.25 - 315.5	IWAMI VOR/DME 115.05 IME CH-97Y 3- 34°40'34"N/131°46'48"E	IWAMI REMOTE 122.2	NO RADAR
---	--	-----------------------	----------

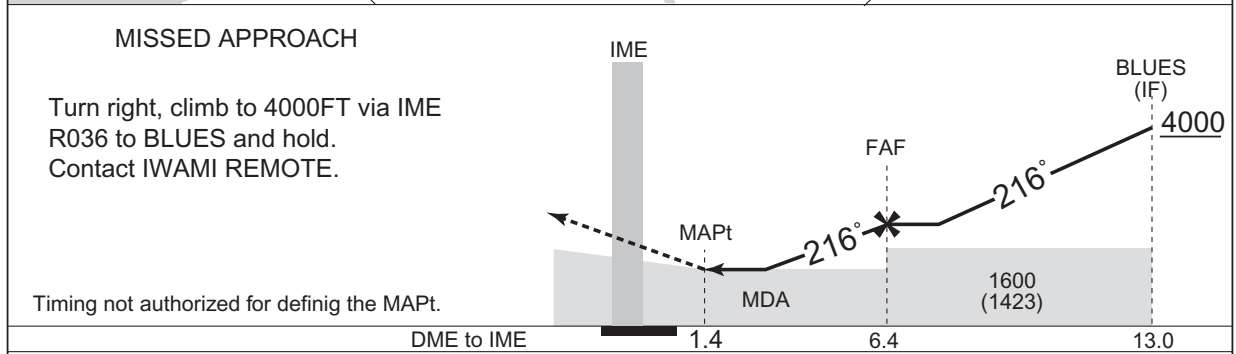
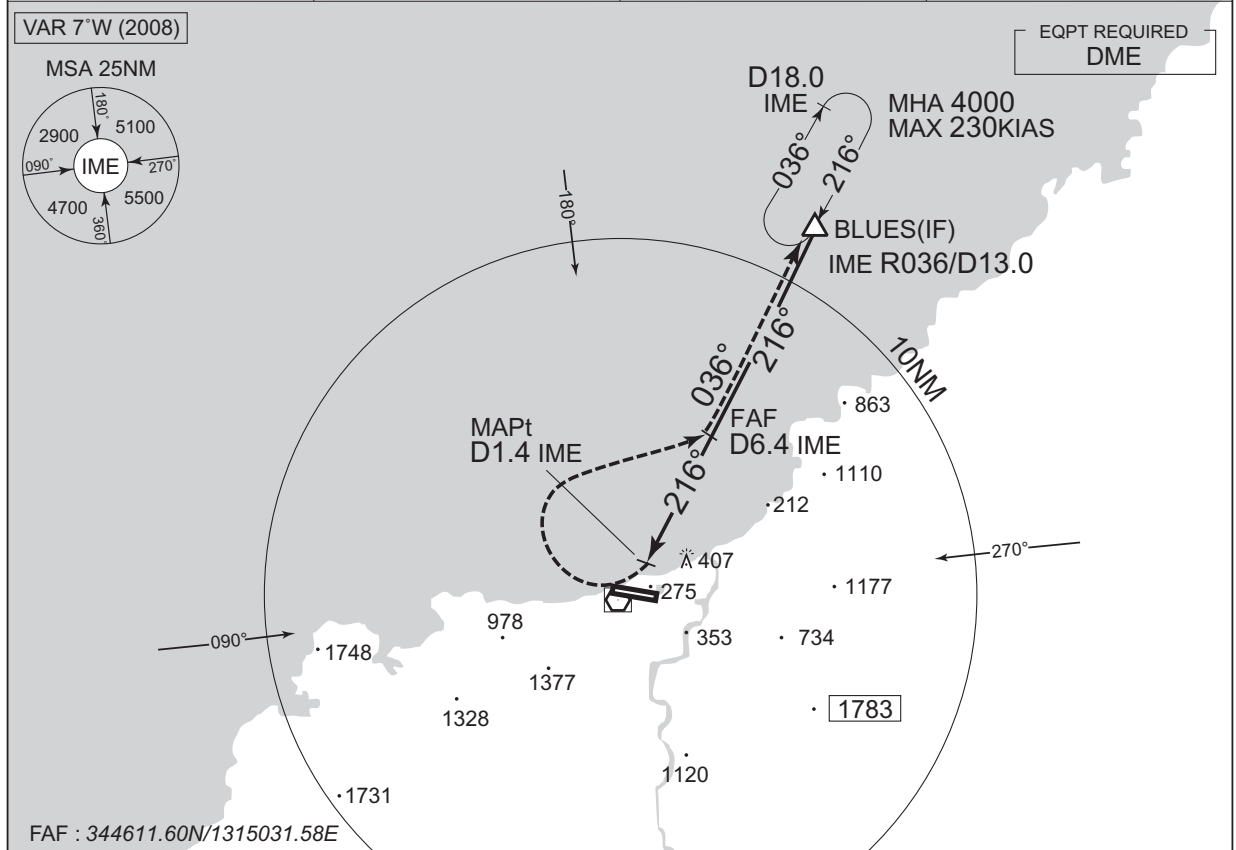

DME to IME 1.4 6.4 13.0

<b>MINIMA</b>		AD elev. 177
CAT	CIRCLING	
	MDA(H)	VIS
A	1000 (823)	1600
B	1100 (923)	
C	1400 (1223)	2400
D	1600 (1423)	3200

CHANGE:ATC call sign.

Circling to NORTH side of RWY only

RJOW / IWAMI

Visual REP



※図中に標高を示す数字がある場合、単位はメートル(m)である。The unit of measurement used to express elevation is meter(m).

CHANGE : Map updated. BRG/DIST from ARP. Remarks.

Call sign	BRG / DIST from ARP	Remarks
魚待 Uomachi	038°T / 6.0NM	岬 Cape
高山 Takayama	266°T / 8.8NM	岬 Cape
日原 Nichihara	166°T / 8.9NM	駅 Station

RJOW / IWAMI LDG CHART

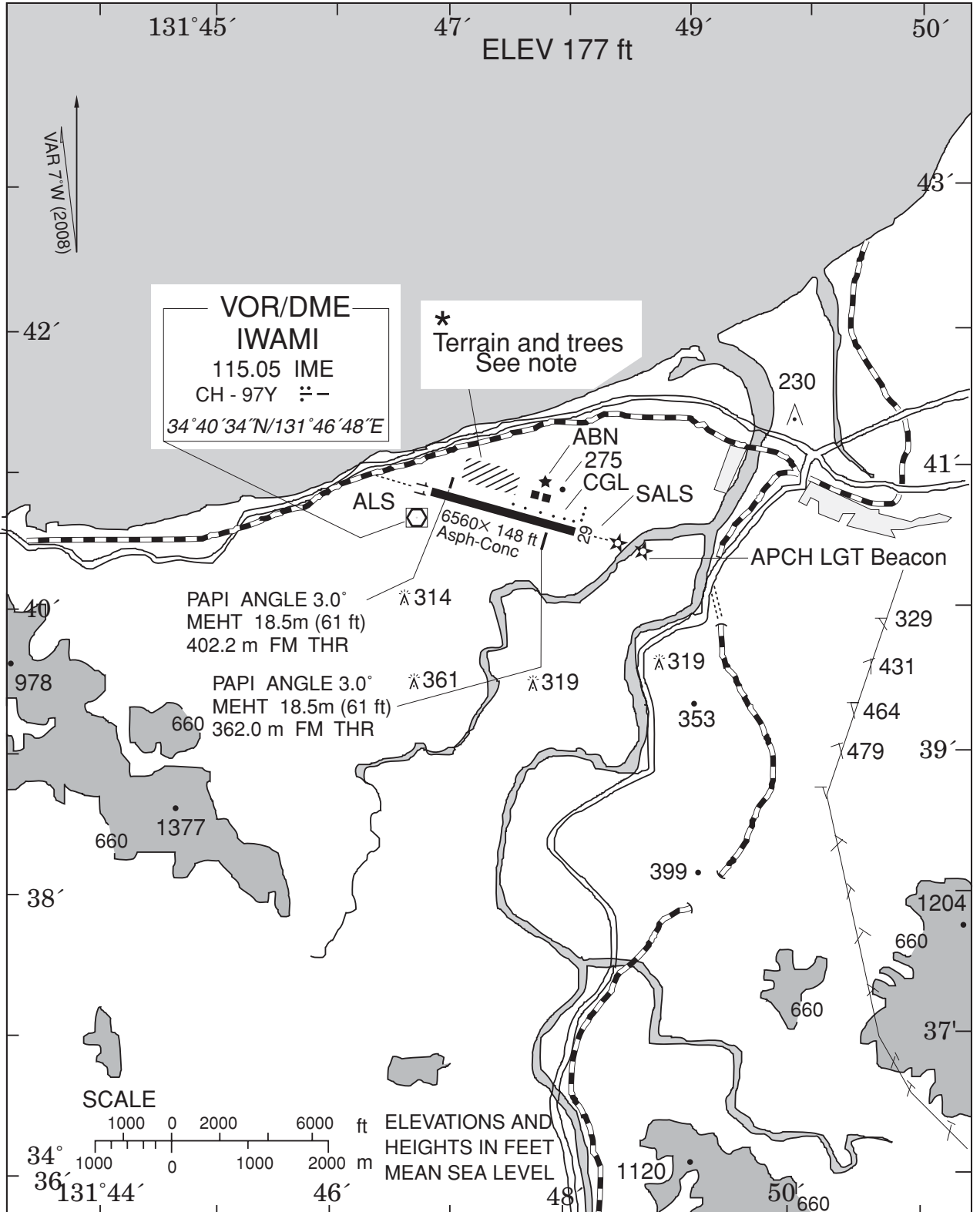

\*Note : RWY may be invisible on downwind leg of northside traffic pattern according to altitude.

CHANGE : Obstacle added



RJOW / IWAMI

Minimum Vectoring Altitude CHART

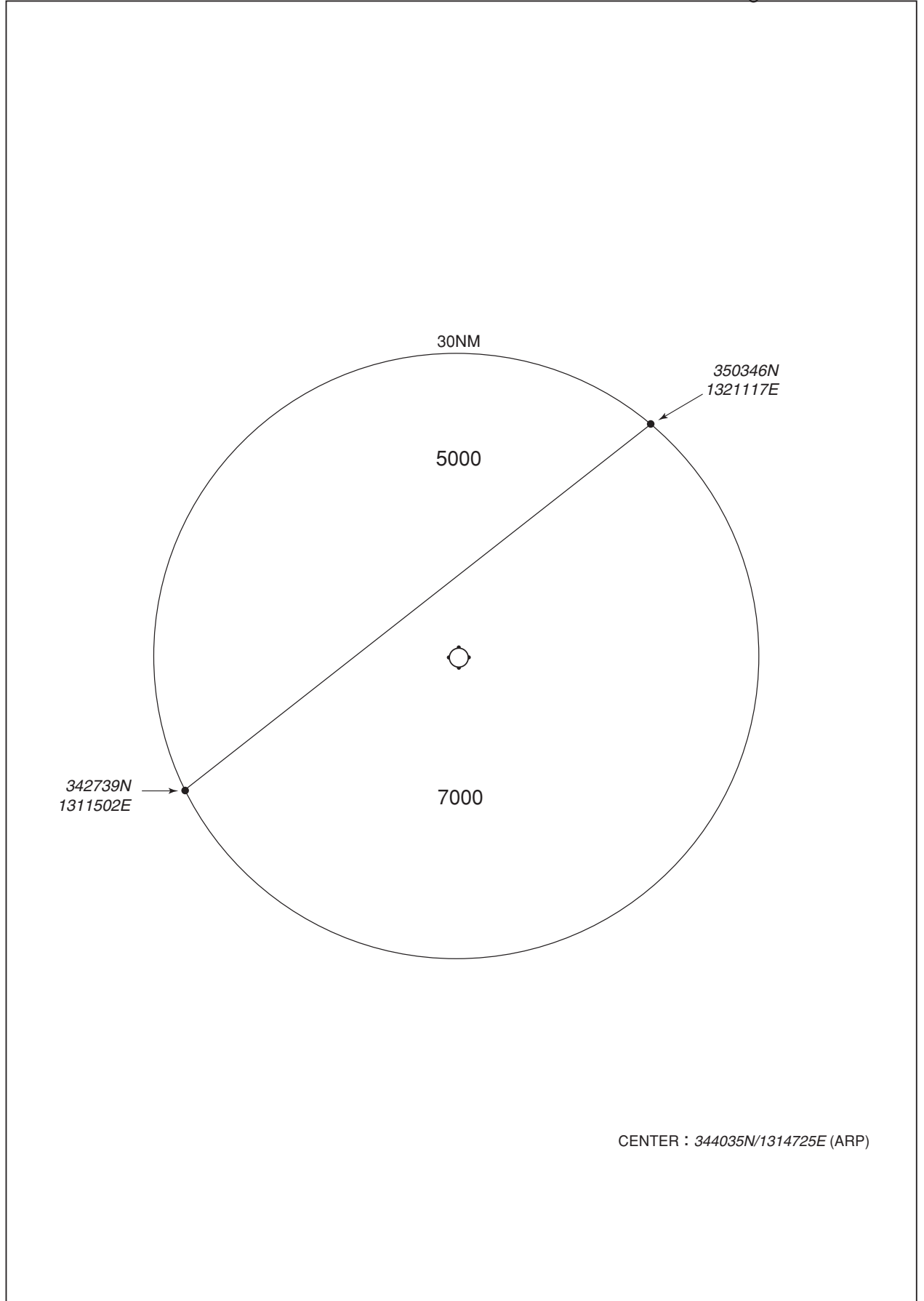

ILS

## IWAMI AP

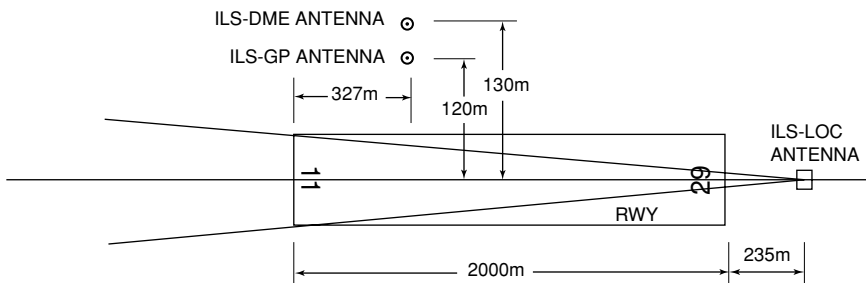

REMARKS : 1. LOC beam BRG(MAG) 112°

2. GP angle 3.0°

3. HGT of ILS REF datum 16.5m(54ft)

4. ELEV of ILS-DME 59.1m(194ft)

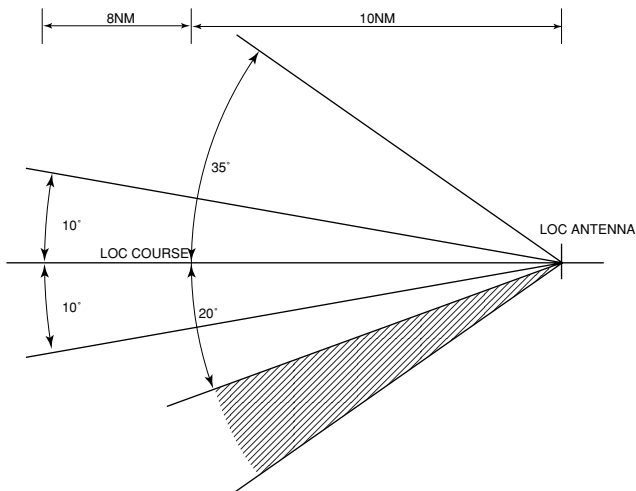

LOC unusable : Beyond 20° south (150Hz) side of LOC course.

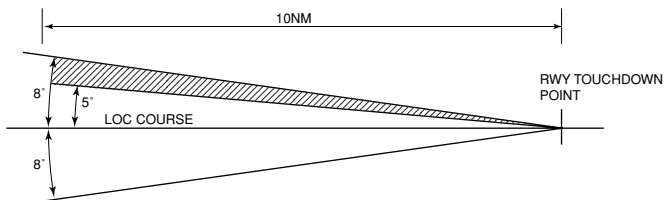

GP unusable : Beyond 5° north (90Hz) side of GP course.

RWY Turn pads are installed as shown in below figure, and procedures for 180° turn on RWY is established for RWY 11 and 29 as follows:

- Proceed along the RWY Center Line to the starting point of the RWY Turn Pad Center Line Marking; then,
- proceed along the RWY Turn Pad Center Line Marking to see the Turning Point Indicator Lights 1 on a straight line, then commence turn at the spot where you (pilot) can see the Turning Point Indicator Lights 2 on a straight line at an angle of 9 o'clock. When turning, take MAX STEERING ANGLE.

