

## AD 2 AERODROMES

## RJOT AD 2.1 AERODROME LOCATION INDICATOR AND NAME

## RJOT - TAKAMATSU

## RJOT AD 2.2 AERODROME GEOGRAPHICAL AND ADMINISTRATIVE DATA

1	ARP coordinates and site at AD	341251N 1340056E 073°/1250m FM RWY 08 THR
2	Direction and distance from (city)	8nm SSW TAKAMATSU city
3	Elevation/ Reference temperature	607ft / 31°C(2002-2006)
4	Geoid undulation at AD ELEV PSN	Nil
5	MAG VAR/ Annual change	7°W(2009) /1.3'W
6	AD Administration, address, telephone, telefax, telex, AFS, e-mail and/or Web-site addresses	Takamatsu Airport Co.,LTD.(TAK) Oka 1312-7 Konan-cho Takamatsu-shi, Kagawa Tel:087-814-3657 Fax:087-814-3658
7	Types of traffic permitted(IFR/VFR)	IFR/VFR
8	Remarks	Takamatsu Airport Office (Civil Aviation Bureau) Yusa 3473-3 Konan-cho Takamatsu-shi, Kagawa Tel:087-879-6770 Fax:087-879-6896

## RJOT AD 2.3 OPERATIONAL HOURS

1	AD Administration	2200 - 1300
2	Customs and immigration	Customs: 2345-1030 Immigration: INTL SKED FLT hours only
3	Health and sanitation	Quarantine(human): 2330-1115 Quarantine(animal): 2330-1000 Quarantine(plant): INTL SKED FLT hours only
4	AIS Briefing Office	Nil
5	ATS Reporting Office(ARO)	Nil
6	MET Briefing Office	H24 (KANSAI)
7	ATS	2200 - 1300
8	Fuelling	2200 - 1300
9	Handling	2200 - 1300
10	Security	2100 - 1100
11	De-icing	Nil
12	Remarks	Nil

**RJOT AD 2.4 HANDLING SERVICES AND FACILITIES**

1	Cargo-handling facilities	All the modern institutions that deal with the weight thing to a Boeing 767 type passenger plane
2	Fuel/ oil types	Fuel types : JET A-1, AVGAS100, Oil types : Nil
3	Fuelling facilities/ capacity	Tank and fuel truck / 720 kl
4	De-icing facilities	Nil
5	Hangar space for visiting aircraft	Nil
6	Repair facilities for visiting aircraft	Nil
7	Remarks	Nil

**RJOT AD 2.5 PASSENGER FACILITIES**

1	Hotels	Nil
2	Restaurants	At Airport
3	Transportation	Buses and Taxi
4	Medical facilities	Nil
5	Bank and Post Office	At Airport
6	Tourist Office	At Airport
7	Remarks	Nil

**RJOT AD 2.6 RESCUE AND FIRE FIGHTING SERVICES**

1	AD category for fire fighting	CAT 9
2	Rescue equipment	Chemical fire fighting truck x 3 Water-supply truck Lighting power supply truck Emergency medical equipment truck
3	Capability for removal of disabled aircraft	Nil
4	Remarks	Nil

**RJOT AD 2.7 SEASONAL AVAILABILITY-CLEARING**

1	Types of clearing equipment	AVBL(Ask AD administration)
2	Clearance priorities	Nil
3	Remarks	Nil

**RJOT AD 2.8 APRONS, TAXIWAYS AND CHECK LOCATIONS DATA**

1	Apron surface and strength	Surface:cement-concrete Strength:PCN 62/R/B/X/T
2	Taxiway width, surface and strength	T-1 and T-5 Width : 32m, Surface : Asphalt, Strength : PCN 67/F/B/X/T T-2 and T-3 Width : 34m, Surface : Asphalt, Strength : PCN 55/F/B/X/T T-4 Width : 34m, Surface : Asphalt, Strength : PCN 47/F/A/X/T P1, P2, P4, P5, P6 Width : 30m, Surface : Asphalt, Strength : PCN 67/F/A/X/T P3 Width : 30m, Surface : Concrete, Strength : PCN 62/R/B/X/T E-TWY Width : 9m, Surface : Asphalt, Strength : PCN 11/F/A/Z/T
3	ACL and elevation	Not available
4	VOR checkpoints	Not available
5	INS checkpoints	Spot NR 1: 341306.85N 1340113.44E 2: 341306.17N 1340111.03E 3: 341305.50N 1340108.42E 5: 341304.94N 1340105.97E 6: 341304.26N 1340103.56E 7: 341303.71N 1340101.13E
6	Remarks	Nil

**RJOT AD 2.9 SURFACE MOVEMENT GUIDANCE AND CONTROL SYSTEM AND MARKINGS**

1	Use of aircraft stand ID signs, TWY guide lines and Visual docking/ parking guidance system of aircraft stands	Aircraft stand identification signs: Spot 2, 3, 5, 6 Aircraft stand taxi lane: T1, T2, T3, T4, T5, E-TWY Visual docking / parking guidance system: Nil
2	RWY and TWY markings and LGT	RWY: RWY 08/26 (Marking) RWY designation, RWY CL, RWY THR, RWY side stripe, TDZ, Aiming point, RWY middle point (LGT) RCLL, REDL, RTHL, RENL, WBAR(RWY26), RTZL(RWY26)  ALL TWY: (Marking) TWY CL, RWY HLDG PSN, TWY side stripe (LGT) TWY edge LGT, TWY CL LGT, Taxiing guidance sign, RWY guard LGT(T1-T5)
3	Stop bars	Nil
4	Remarks	(Marking) Overrun area (LGT) APN flood LGT

## RJOT AD 2.10 AERODROME OBSTACLES

In approach/TKOF areas

RWY/Area affected	Obstacle type	Coordinates	Elevation	Markings / LGT	Remarks
Nil					

In circling area and at AD

Obstacle type	Coordinates	Elevation	Markings / LGT	Remarks
Nil				

## RJOT AD 2.11 METEOROLOGICAL INFORMATION PROVIDED

1	Associated MET Office	KANSAI
2	Hours of service MET Office outside hours	H24 (KANSAI)
3	Office responsible for TAF preparation Periods of validity	KANSAI 30 Hours
4	Trend forecast Interval of issuance	Nil
5	Briefing/ consultation provided	Briefing is available upon inquiry at KANSAI
6	Flight documentation Language(s) used	C En
7	Charts and other information available for briefing or consultation	S <sub>6</sub> , U <sub>85</sub> , U <sub>7</sub> , U <sub>5</sub> , U <sub>3</sub> , U <sub>25</sub> , U <sub>2/T<sub>r</sub></sub> , P <sub>s</sub> , P <sub>5</sub> , P <sub>3</sub> , P <sub>25</sub> , P <sub>SWE</sub> , P <sub>SWF</sub> , P <sub>SWG</sub> , P <sub>SWI</sub> , P <sub>SWM</sub> , P <sub>SW</sub> (domestic), E, C, W <sub>E</sub> , W <sub>F</sub> , W <sub>G</sub> , W <sub>I</sub> , W, N
8	Supplementary equipment available for providing information	Nil
9	ATS units provided with information	TWR, APP, ATIS
10	Additional information(limitation of service, etc.)	Nil

**RJOT AD 2.12 RUNWAY PHYSICAL CHARACTERISTICS**

Designations RWY NR	TRUE BRG	Dimensions of RWY(M)	Strength(PCN) and surface of RWY	THR coordinates THR geoid undulation	THR elevation and highest elevation of TDZ of precision APP RWY
1	2	3	4	5	6
08	072.90°	2500×60	PCN 59/F/A/X/T Asphalt-Concrete	341238.66N 1340010.11E	THR ELEV: 583ft
26	252.90°	2500×60	PCN 59/F/A/X/T Asphalt-Concrete	341302.52N 1340143.45E	THR ELEV: 586.2ft TDZ ELEV: 605ft
Slope of RWY		Strip Dimensions(M)	RESA(Overrun) Dimensions(M)		Remarks
7	10		11		14
See AD2.24 AD Chart		2620×300	41x300		RWY Grooving 2500×40
		2620×300	198x(MNM:140 MAX:300)*		
*For detail, ask airport administrator					

**RJOT AD 2.13 DECLARED DISTANCES**

RWY Designator	TORA (m)	TODA (m)	ASDA (m)	LDA (m)	Remarks
1	2	3	4	5	6
08	2500	2500	2500	2500	Nil
TWY:T4	1940	1940	1940		
26	2500	2500	2500	2500	Nil
TWY:T2	1940	1940	1940		

TORA,TODA and ASDA for TWY Indicate distances BTN the point where TWY CL meets RWY CL and RWY THR.

**RJOT AD 2.14 APPROACH AND RUNWAY LIGHTING**

RWY Designator	APCH LGT type LEN INTST	RTHL Color WBAR	PAPI (VASIS) Angle DIST FM THR MEHT	RTZL LEN	RCLL LEN Spacing Color INTST	REDL LEN Spacing Color INTST	RENL Color WBAR	STWL LEN Color
1	2	3	4	5	6	7	8	9
08	SALS(*1) 420m LIH	Green -	PAPI(*2) 3.0°/Left 403m 74ft	-	2400m 30m Coded color (White/Red) LIH	2400m 60m Coded color (White/Yellow) LIH	Red	Nil(*3)
26	PALS (CAT I) 900m LIH	Green Green	PAPI 3.0°/Left 363m 65.6ft	900m	2400m 30m Coded color (White/Red) LIH	2400m 60m Coded color (White/Yellow) LIH	Red	Nil(*3)
Remarks								
10								
SALS with APCH LGT beacon(600m and 900m FM RWY THR)(*1) Usable area of PAPI for RWY 08 is within APRX 3.0NM FM RWY 08 THR(See below figure)(*2) Overrun area edge LGT(LEN:60m Color:Red)(*3) CGL for RWY 08								

滑走路08側の進入角指示灯（PAPI）の使用範囲は、障害物（山及び樹木）のため滑走路08末端から約3.0NM以内とする。

Usable area of PAPI for Runway 08 is within approx 3.0NM from Runway 08 threshold.

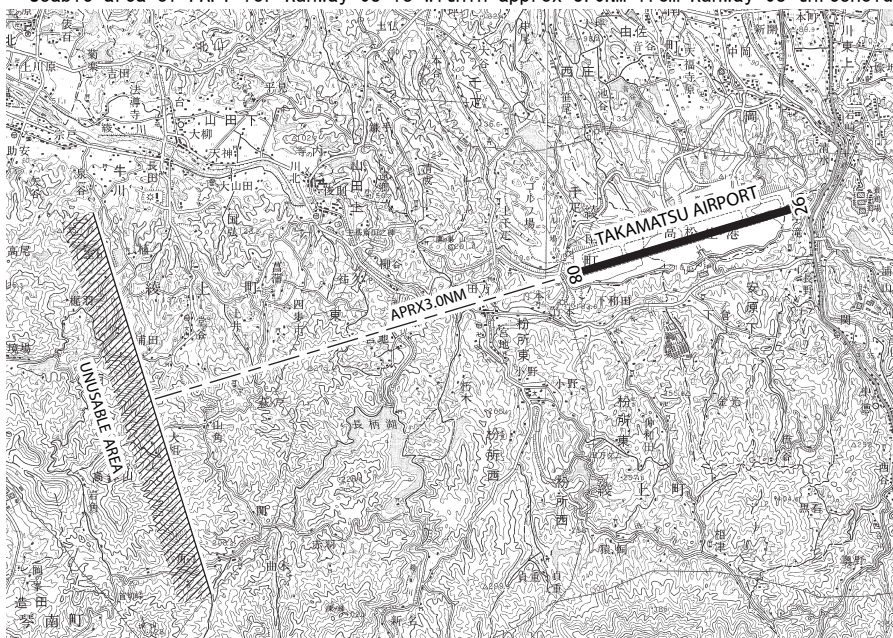

**RJOT AD 2.15 OTHER LIGHTING, SECONDARY POWER SUPPLY**

1	ABN/IBN location, characteristics and hours of operation	ABN: 341304N/1340051E, White/Green EV4.3sec, HO
2	LDI location and LGT Anemometer location and LGT	LDI:Nil Anemometer : 145m FM RWY08/26 THR, LGTD
3	TWY edge and center line lighting	TWY edge and center line lights installed, see AD2.9
4	Secondary power supply/ switch-over time	Within 1 sec : REDL, RENL, RTHL, WBAR, RCLL, Overrun area edge LGT Within 15 sec: Other LGT
5	Remarks	WDI LGT

**RJOT AD 2.16 HELICOPTER LANDING AREA**

Nil
-----

**RJOT AD 2.17 ATS AIRSPACE**

Designation and lateral limits		Vertical limits (ft)	Airspace classification	ATS unit call sign Language	Remarks
1		2	3	4	6
TAKAMATSU CTR	Area within a radius of 5nm of TAKAMATSU ARP(34°13'N 134°01'E)	3000 or below	D	TAKAMATSU TWR En	
TAKAMATSU PCA	See attached chart		C	KANSAI APP KANSAI RADAR TAKAMATSU TWR En	
KANSAI ACA	See RJBB attached chart		E	KANSAI APP KANSAI DEP KANSAI RADAR En	
KANSAI TCA	See RJBB attached chart		E	KANSAI TCA En	

高松特別管制区  
Takamatsu Positive Control Area

NAME	LATERAL LIMITS	UPPER LIMIT (AMSL)	UNIT PROVIDING SERVICE	REMARKS
		LOWER LIMIT (AMSL) M(ft)		
1	2	3	4	5
高松 Takamatsu	下記に示される区域 The area shown below		Primary Kansai APP or Radar 121.2 MHz  Secondary Takamatsu TWR 118.3 MHz	当該空域を飛行しようとする航空機は、関西アプローチ又は高松タワーに連絡し、コールサイン、現在位置、高度及び意図を通報し指示を受けること。  Pilot of aircraft operating in this area shall contact Kansai Approach or Takamatsu Tower for ATC instructions giving informations on aircraft identification, positions, altitude and pilot's intentions.

TAKAMATSU POSITIVE CONTROL AREA

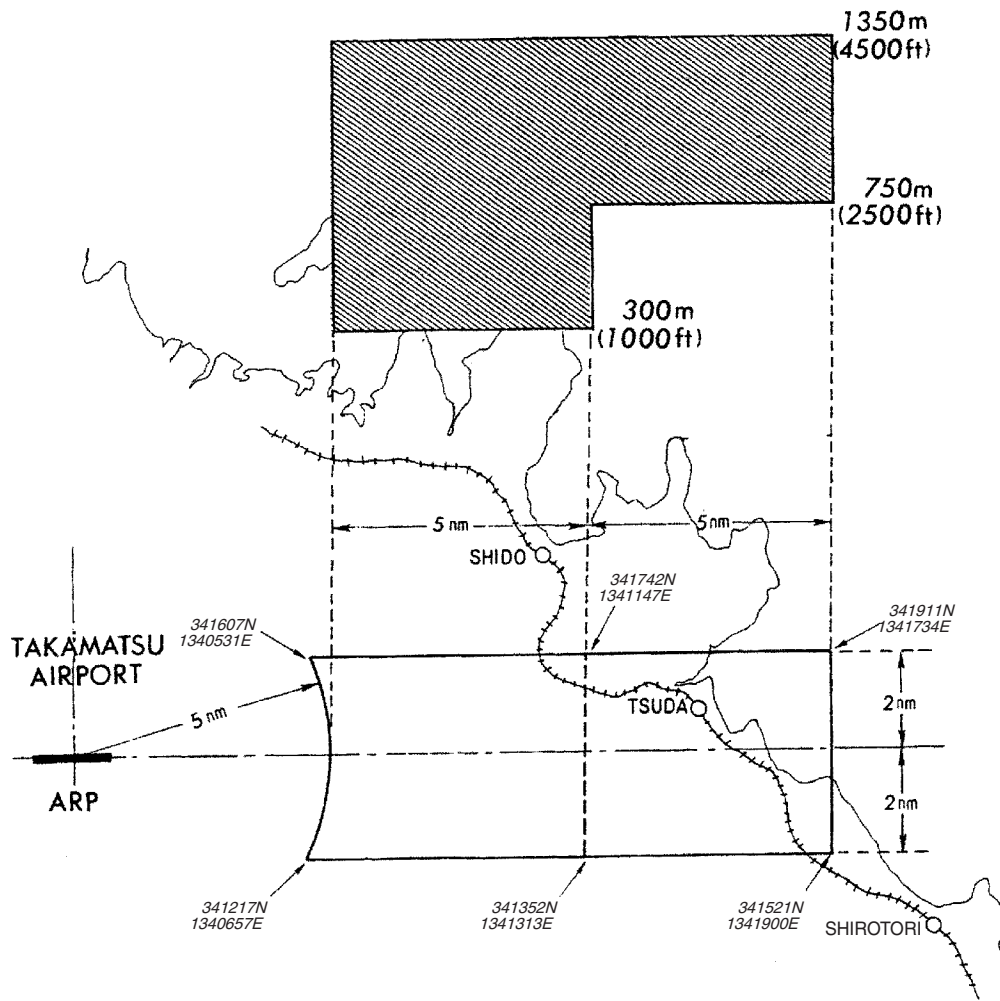



RJOT AD 2.18 ATS COMMUNICATION FACILITIES

Service designation	Call sign	Frequency	Hours of operation	Remarks
1	2	3	4	5
APP/ASR	Kansai Approach/ Kansai Radar	121.2MHz(1) 120.4MHz 261.2MHz 121.5MHz(E) 243.0MHz(E)	2200 - 1300	(1)Primary (2)Position report  APP Service provided by KANSAI APP
DEP	Kansai Departure	120.4MHz 121.2MHz 261.2MHz 121.5MHz(E) 243.0MHz(E)	2200 - 1300	
TCA	Kansai TCA	119.025MHz 315.800MHz	2300 - 1030	
TWR	Takamatsu Tower	118.3MHz(1) 126.2MHz 135.9MHz(2) 261.2MHz 121.5MHz(E) 243.0MHz(E)	2200 - 1300	
ATIS	Takamatsu Airport	127.45MHz	2200 - 1300	

RJOT AD 2.19 RADIO NAVIGATION AND LANDING AIDS

Type of aid (VOR declination)	ID	Frequency	Hours of operation	Position of transmitting antenna coordinates	Elevation of DME transmitting antenna	Remarks
1	2	3	4	5	6	7
VOR (7°W / 2016)	KTE	108.4MHz	H24	341244.99N 1340121.33E		VOR unusable: 090°-110° beyond 30nm BLW 5000ft. 110°-140° beyond 25nm BLW 6000ft. 140°-240° beyond 20nm BLW 9000ft.
DME	KTE	982MHz (CH-21X)	H24	341244.33N 1340120.27E	696ft	DME unusable: 090°-110° beyond 30nm BLW 5000ft. 110°-140° beyond 20nm BLW 6000ft. 140°-240° beyond 20nm BLW 9000ft.
ILS-LOC 26	IKT	109.7MHz	2200 - 1300	341236.41N 1340001.32E		LOC:235m(771ft) away FM RWY 08 THR. BRG(MAG)261°. LOC Unusable beyond 15° S side of LOC course.
ILS-GP 26	-	333.2MHz	2200 - 1300	341255.98N 1340134.48E		GP:278m(912ft) inside FM RWY 26 THR, 125m(410ft) S of RCL. HGT of ILS REF datum 16.3m(53ft).
ILS-DME 26	IKT	995MHz	2200 - 1300	341255.66N 1340134.58E	604ft	DME:280m(919ft) inside FM RWY 26 THR. 135m(444ft) S of RCL.
MSAS		1575.42MHz	H24			Transmitting antennas are satellite based.

TAKAMATSU AIRPORT

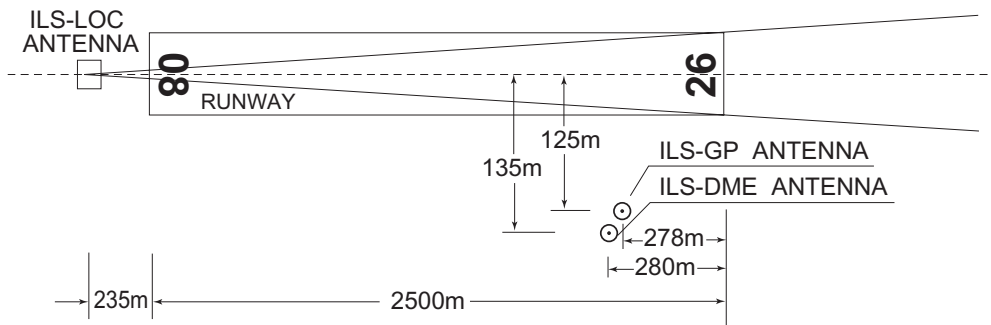

- REMARKS : 1. LOC beam BRG(MAG) 261°  
 2. HGT of ILS REF datum 16.3m(53ft)  
 3. GP Angle 3.0°  
 4. ELEV of ILS-DME 183.9m(604ft)

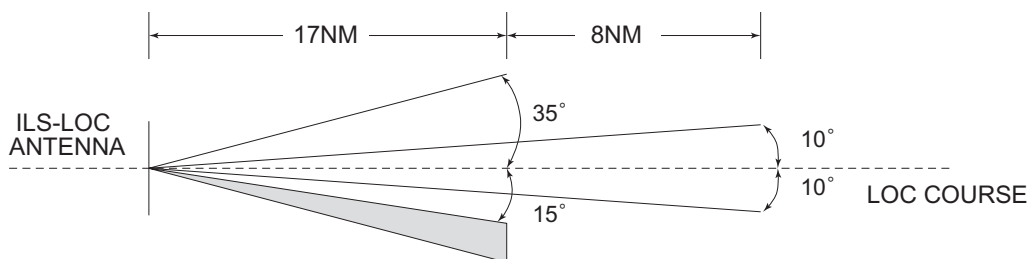

LOC Unusable beyond 15° South side of LOC course.

**RJOT AD 2.20 LOCAL TRAFFIC REGULATIONS**

1. Airport regulations

**PPR**

Prior permission is required for all transient aircraft due to parking congestion except scheduled and/or emergency flight.  
Tel : RJOT TAK OPR 087-879-6771

2. Taxiing to and from stands

Nil

3. Parking area for small aircraft(General aviation)

Nil

4. Parking area for helicopters

Nil

5. Apron - taxiing during winter conditions

Nil

6. Taxiing - limitations

**Wing tip clearance at the TWY intersection (REF AD1.1.6.8)**

Wing tip clearance at the TWY intersection between the aircraft holding at the stop marking on the TWY and the other aircraft taxiing behind it are as follows.

When B772 holding at the stop marking on TWY T3

wing span (WS) of acft taxiing on TWY P4-P5	WS =<35.6m	35.6m <WS =<52.6m	WS >52.6m	Legend
wing tip clearance	*A	*B	*C	*A : wing tip clearance >= 15m *B : 6.5m =< wing tip clearance < 15m *C : wing tip clearance < 6.5m

7. School and training flights - technical test flights - use of runways

Nil

8. Helicopter traffic - limitation

**TKOF and LDG for EAST-HELIPAD and WEST-HELIPAD**

Fly along the parallel taxiway. Do not fly over the buildings in airport terminal.

9. Removal of disabled aircraft from runways

Nil

**RJOT AD 2.21 NOISE ABATEMENT PROCEDURES**

Nil

## RJOT AD 2.22 FLIGHT PROCEDURES

1.TAKE OFF MINIMA								
	RWY	ACFT CAT	REDL & RCLL		REDL or RCLL or RCL Marking		NIL (DAYTIME ONLY)	
			RVR	VIS	RVR	VIS	RVR	VIS
Multi-Engine ACFT with TKOF ALTN AP FILED	08	A,B,C,D	-	400m	-	400m	-	500m
	26		400m	400m	400m	400m	-	500m
OTHER	08	A,B,C,D	AVBL LDG MINIMA					
	26							

**2.Lost communication procedures for arrival aircraft under radar navigational guidance**

If radio communications with KANSAI Approach/Radar are lost for 1 minute, squawk Mode A/3 Code 7600 and;

- (I)
1. Contact TAKAMATSU Tower.
  2. If unable, proceed in accordance with visual flight rules,
  3. If unable,
    - (1) When the aircraft is at or above 5,000ft, proceed to KAGAWA VOR/DME maintaining the last assigned altitude or 5,000ft whichever is higher and execute Instrument approach.
    - (2) When the aircraft is below 5,000ft,
      - a.and established on a segment of the Instrument Approach Procedure, execute Instrument Approach.
      - b.and not yet established on a segment of the Instrument Approach Procedure, climb and maintain 5,000 feet and proceed to KAGAWA VOR/DME and execute instrument approach.
- (II) Procedures other than above will be issued when situation required.

## RJOT AD 2.23 ADDITIONAL INFORMATION

Nil

## RJOT AD 2.24 CHARTS RELATED TO AN AERODROME

Aerodrome Chart  
 Aerodrome Obstacle Chart-ICAO type A (RWY26)  
 Aerodrome Obstacle Chart-ICAO type A (RWY08)  
 Aerodrome Obstacle Chart-ICAO type B  
 Standard Departure Chart-Instrument (KAGAWA NORTH, KAGAWA REVERSAL)  
 Standard Departure Chart-Instrument (SAYOH-RNAV)  
 Standard Departure Chart-Instrument (WASYU-RNAV)  
 Standard Departure Chart-Instrument (TAROH-RNAV)  
 Standard Departure Chart-Instrument (OLIVE-RNAV)  
 Standard Arrival Chart-Instrument (KAGAWA)  
 Standard Arrival Chart-Instrument (POPAI-RNAV)  
 Instrument Approach Chart (ILS Z or LOC Z RWY26)  
 Instrument Approach Chart (ILS Y or LOC Y RWY26)  
 Instrument Approach Chart (VOR RWY26)  
 Instrument Approach Chart (VOR A)  
 Other Chart (Visual REP)  
 Other Chart (LDG CHART)  
 Other Chart (MVA CHART)

RJOT / TAKAMATSU

AD CHART

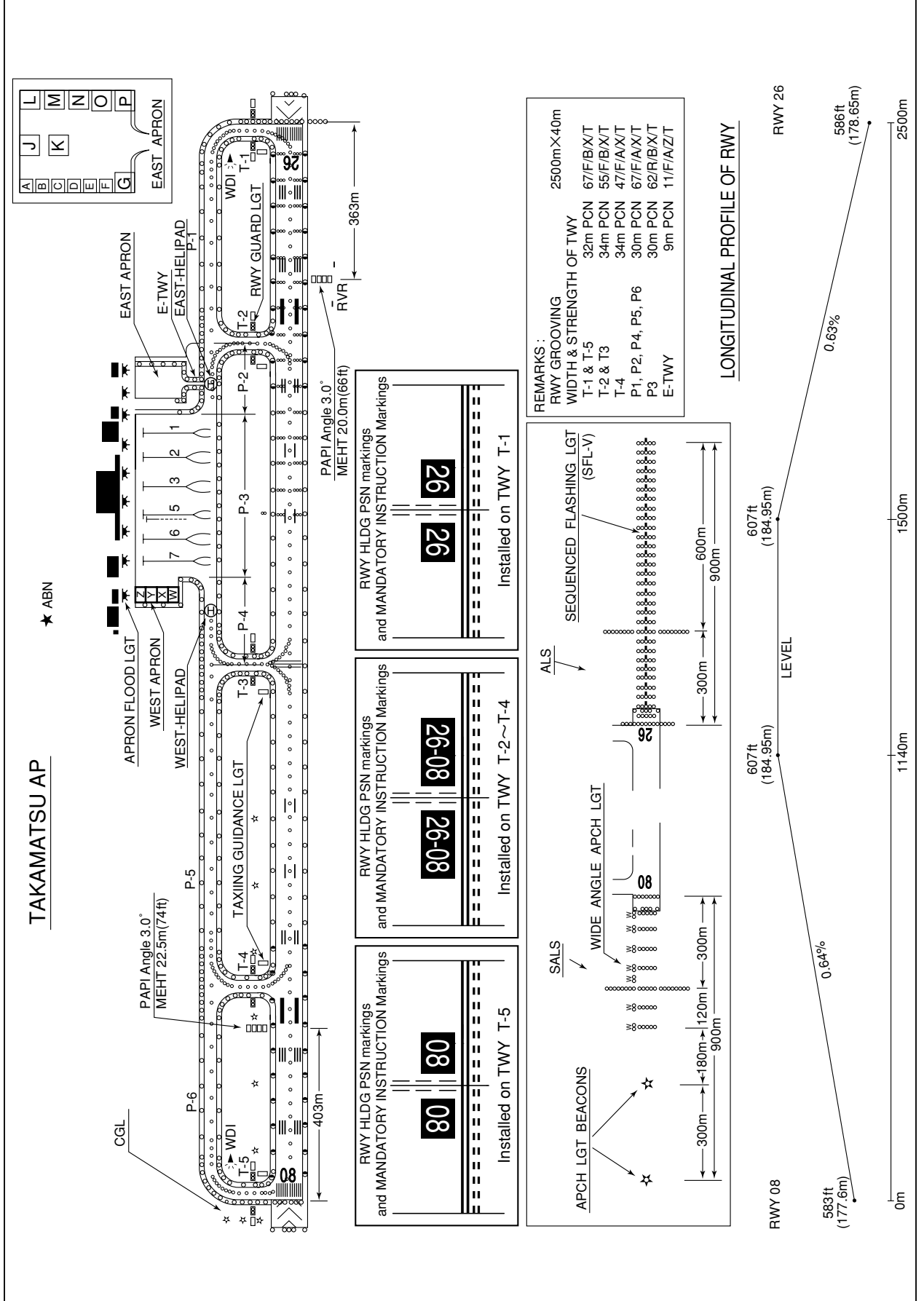

RJOT / TAKAMATSU

LDG CHART

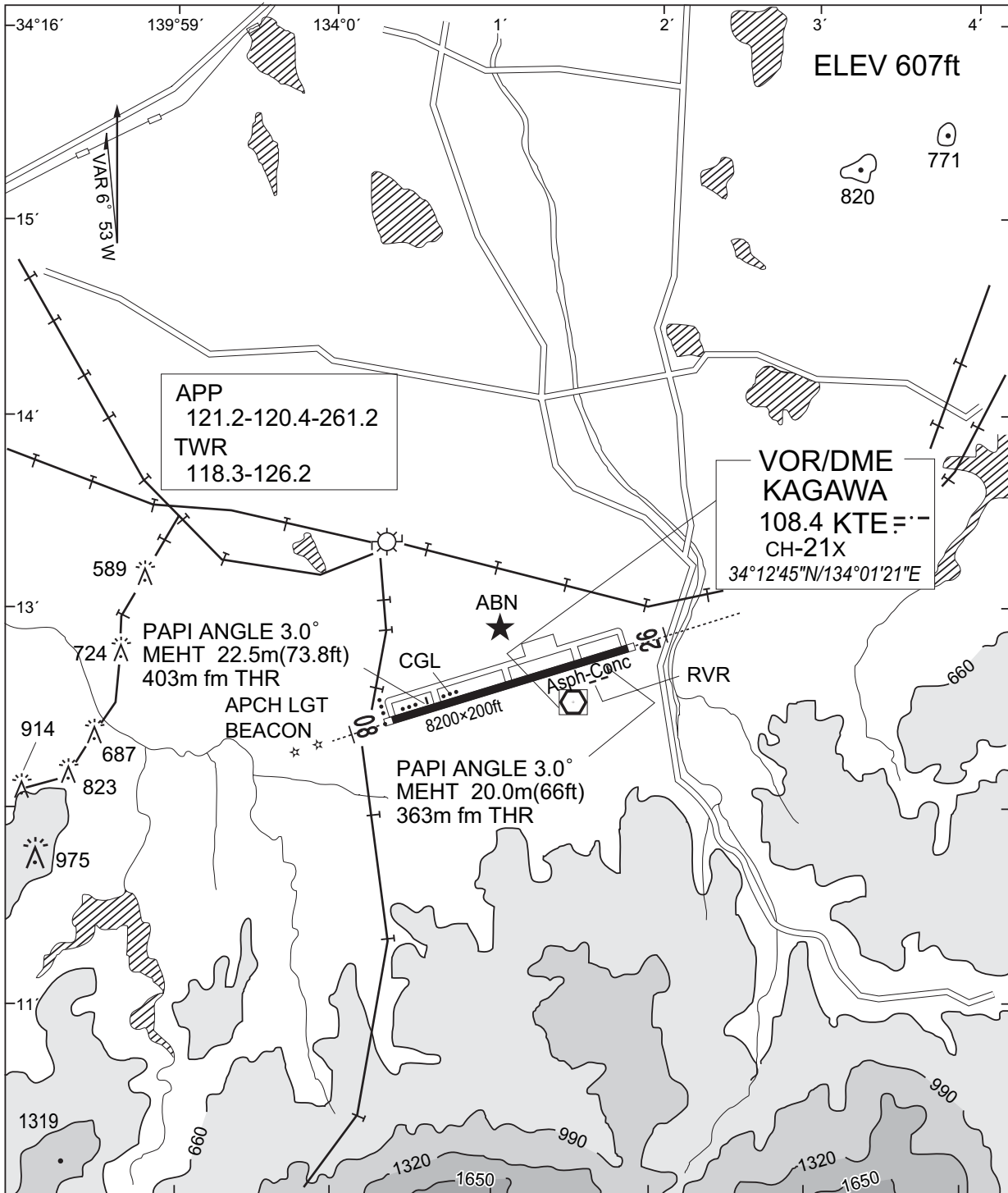

STANDARD DEPARTURE CHART-INSTRUMENT

RJOT / TAKAMATSU

RNAV SID and TRANSITION

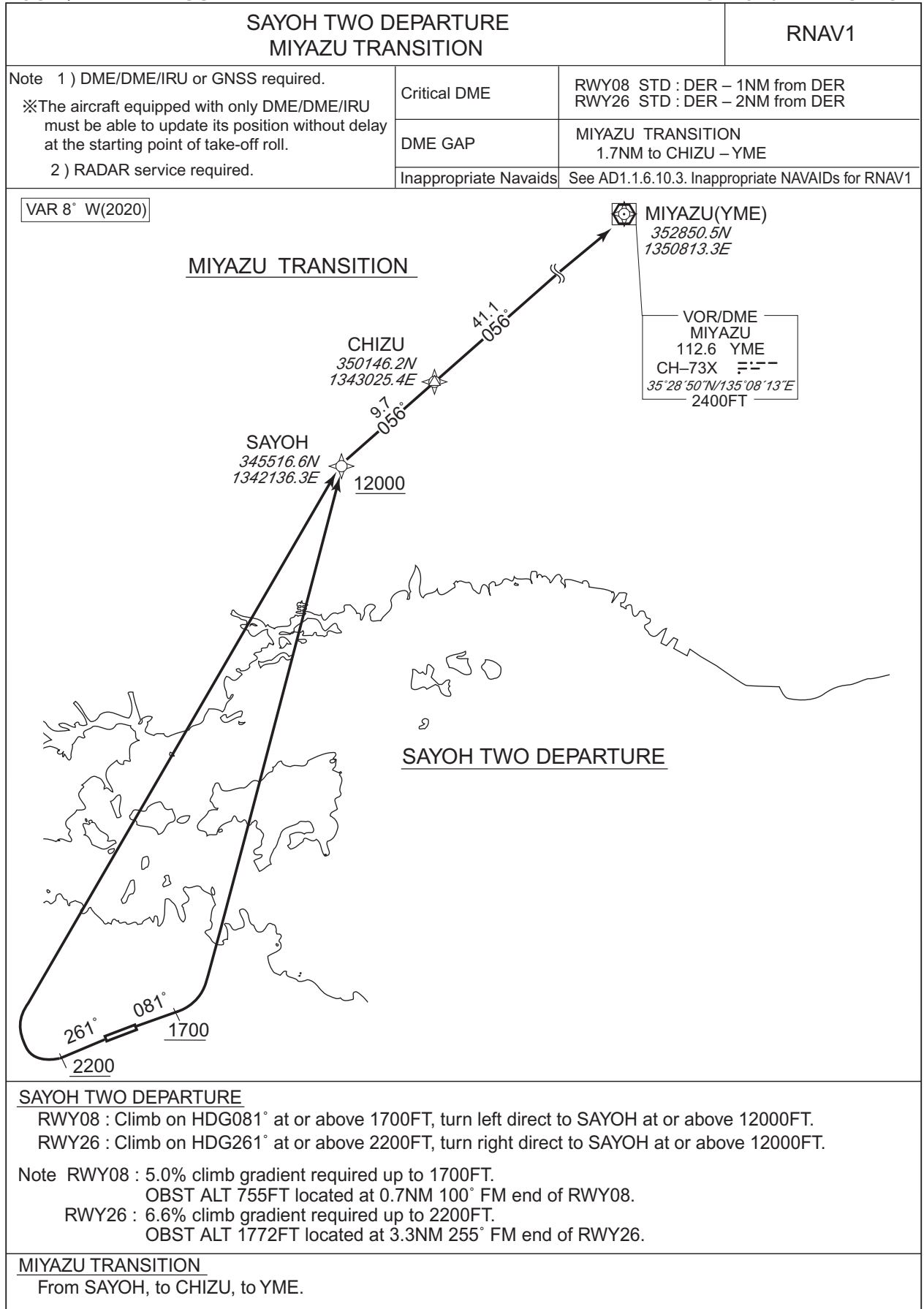

CHANGE : VAR. SID renamed. PROC course. Critical DME. DME GAP. MIYAZU(FIX symbol).

## STANDARD DEPARTURE CHART-INSTRUMENT

RJOT / TAKAMATSU

RNAV SID and TRANSITION

SAYOH TWO DEPARTURE

## RWY08

Serial Number	Path Descriptor	Waypoint Identifier	Fly Over	Course °M(°T)	Magnetic Variation	Distance (NM)	Turn Direction	Altitude (FT)	Speed (KIAS)	Vertical Angle	Navigation Specification
001	VA	—	—	081 (072.9)	-7.8	—	—	+1700	—	—	RNAV1
002	DF	SAYOH	—	—	-7.8	—	L	+12000	—	—	RNAV1

## RWY26

Serial Number	Path Descriptor	Waypoint Identifier	Fly Over	Course °M(°T)	Magnetic Variation	Distance (NM)	Turn Direction	Altitude (FT)	Speed (KIAS)	Vertical Angle	Navigation Specification
001	VA	—	—	261 (252.9)	-7.8	—	—	+2200	—	—	RNAV1
002	DF	SAYOH	—	—	-7.8	—	R	+12000	—	—	RNAV1

MIYAZU TRANSITION

Serial Number	Path Descriptor	Waypoint Identifier	Fly Over	Course °M(°T)	Magnetic Variation	Distance (NM)	Turn Direction	Altitude (FT)	Speed (KIAS)	Vertical Angle	Navigation Specification
001	IF	SAYOH	—	—	-7.8	—	—	—	—	—	RNAV1
002	TF	CHIZU	—	056 (048.0)	-7.8	9.7	—	—	—	—	RNAV1
003	TF	YME	—	056 (048.6)	-7.8	41.1	—	—	—	—	RNAV1

CHANGE : VAR. SID renamed. PROC course.



STANDARD DEPARTURE CHART-INSTRUMENT

RJOT / TAKAMATSU

RNAV SID

WASYU THREE DEPARTURE		RNAV 1
Note 1 ) DME/DME/IRU or GNSS required. ※The aircraft equipped with only DME/DME/IRU must be able to update its position without delay at the starting point of take-off roll. 2 ) RADAR service required.	Critical DME	RWY08 STD : DER – 1NM from DER RWY26 STD : DER – 2NM from DER
	DME GAP	–
	Inappropriate Navaids	See AD1.1.6.10.3. Inappropriate NAVAIDs for RNAV1

VAR 8° W(2020)

CHANGE : VAR. PROC renamed. PROC course.

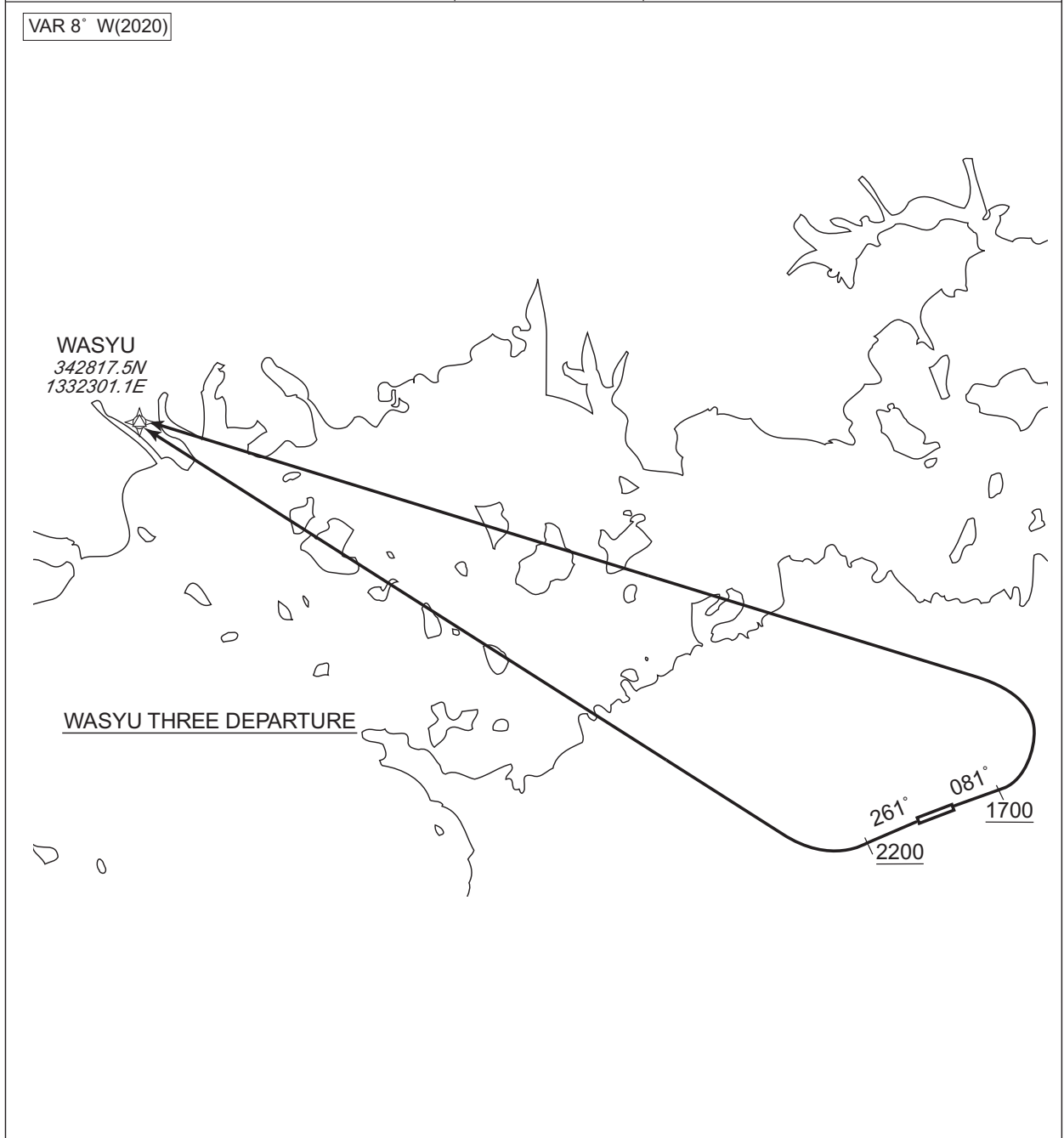

WASYU THREE DEPARTURE

RWY08 : Climb on HDG081° at or above 1700FT, turn left direct to WASYU.  
 RWY26 : Climb on HDG261° at or above 2200FT, turn right direct to WASYU.

Note RWY08: 5.0% climb gradient required up to 1700FT.  
 OBST ALT 755FT located at 0.7NM 100° FM end of RWY08.  
 RWY26: 6.6% climb gradient required up to 2200FT.  
 OBST ALT 1772FT located at 3.3NM 255° FM end of RWY26.

## STANDARD DEPARTURE CHART-INSTRUMENT

RJOT / TAKAMATSU

RNAV SID

WASYU THREE DEPARTURE

## RWY08

Serial Number	Path Descriptor	Waypoint Identifier	Fly Over	Course °M(°T)	Magnetic Variation	Distance (NM)	Turn Direction	Altitude (FT)	Speed (KIAS)	Vertical Angle	Navigation Specification
001	VA	—	—	081 (072.9)	-7.8	—	—	+1700	—	—	RNAV1
002	DF	WASYU	—	—	-7.8	—	L	—	—	—	RNAV1

## RWY26

Serial Number	Path Descriptor	Waypoint Identifier	Fly Over	Course °M(°T)	Magnetic Variation	Distance (NM)	Turn Direction	Altitude (FT)	Speed (KIAS)	Vertical Angle	Navigation Specification
001	VA	—	—	261 (252.9)	-7.8	—	—	+2200	—	—	RNAV1
002	DF	WASYU	—	—	-7.8	—	R	—	—	—	RNAV1

CHANGE : VAR. PROC renamed. PROC course.

STANDARD DEPARTURE CHART-INSTRUMENT

RJOT / TAKAMATSU RNAV SID and TRANSITION

TAROH THREE DEPARTURE MIHO TRANSITION		RNAV 1
<p>Note 1) DME/DME/IRU or GNSS required.                      ※The aircraft equipped with only DME/DME/IRU must be able to update its position without delay at the starting point of take-off roll.                      2) RADAR service required.</p>	<p>Critical DME</p> <hr/> <p>DME GAP</p> <hr/> <p>Inappropriate Navaids</p>	<p>RWY08 STD : DER – 1NM from DER                      RWY26 STD : DER – 2NM from DER                      MIHO TRANSITION                      HGE : 50NM to MIHOU – 36NM to MIHOU                      OIE : 5NM to MIHOU – MIHOU</p> <hr/> <p style="text-align: center;">-</p> <hr/> <p>See AD1.1.6.10.3. Inappropriate NAVAIDs for RNAV1</p>
<div style="border: 1px solid black; display: inline-block; padding: 2px;">VAR 8° W(2020)</div> 		
<p><b>TAROH THREE DEPARTURE</b></p> <p>RWY08 : Climb on HDG081° at or above 1700FT, turn left direct to TAROH.                      RWY26 : Climb on HDG261° at or above 2200FT, turn right direct to TAROH.</p> <p>Note RWY08: 5.0% climb gradient required up to 1700FT.                      OBST ALT 755FT located at 0.7NM 100° FM end of RWY08.                      RWY26: 6.6% climb gradient required up to 2200FT.                      OBST ALT 1772FT located at 3.3NM 255° FM end of RWY26.</p>		
<p><b>MIHO TRANSITION</b></p> <p>From TAROH, to MIHOU.</p>		

CHANGE : VAR. SID renamed. PROC course.

## STANDARD DEPARTURE CHART-INSTRUMENT

RJOT / TAKAMATSU

RNAV SID and TRANSITION

TAROH THREE DEPARTURE

## RWY08

Serial Number	Path Descriptor	Waypoint Identifier	Fly Over	Course °M(°T)	Magnetic Variation	Distance (NM)	Turn Direction	Altitude (FT)	Speed (KIAS)	Vertical Angle	Navigation Specification
001	VA	—	—	081 (072.9)	-7.8	—	—	+1700	—	—	RNAV1
002	DF	TAROH	—	—	-7.8	—	L	—	—	—	RNAV1

## RWY26

Serial Number	Path Descriptor	Waypoint Identifier	Fly Over	Course °M(°T)	Magnetic Variation	Distance (NM)	Turn Direction	Altitude (FT)	Speed (KIAS)	Vertical Angle	Navigation Specification
001	VA	—	—	261 (252.9)	-7.8	—	—	+2200	—	—	RNAV1
002	DF	TAROH	—	—	-7.8	—	R	—	—	—	RNAV1

MIHO TRANSITION

Serial Number	Path Descriptor	Waypoint Identifier	Fly Over	Course °M(°T)	Magnetic Variation	Distance (NM)	Turn Direction	Altitude (FT)	Speed (KIAS)	Vertical Angle	Navigation Specification
001	IF	TAROH	—	—	-7.8	—	—	—	—	—	RNAV1
002	TF	MIHOU	—	334 (325.8)	-7.8	59.2	—	—	—	—	RNAV1

CHANGE : VAR. SID renamed. PROC course.

AERODROME OBSTACLE CHART-ICAO  
TYPE B

DIMENSIONS AND ELEVATIONS IN FEET BEARINGS ARE MAGNETIC

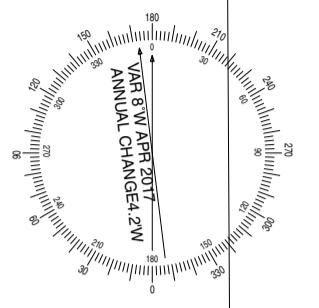
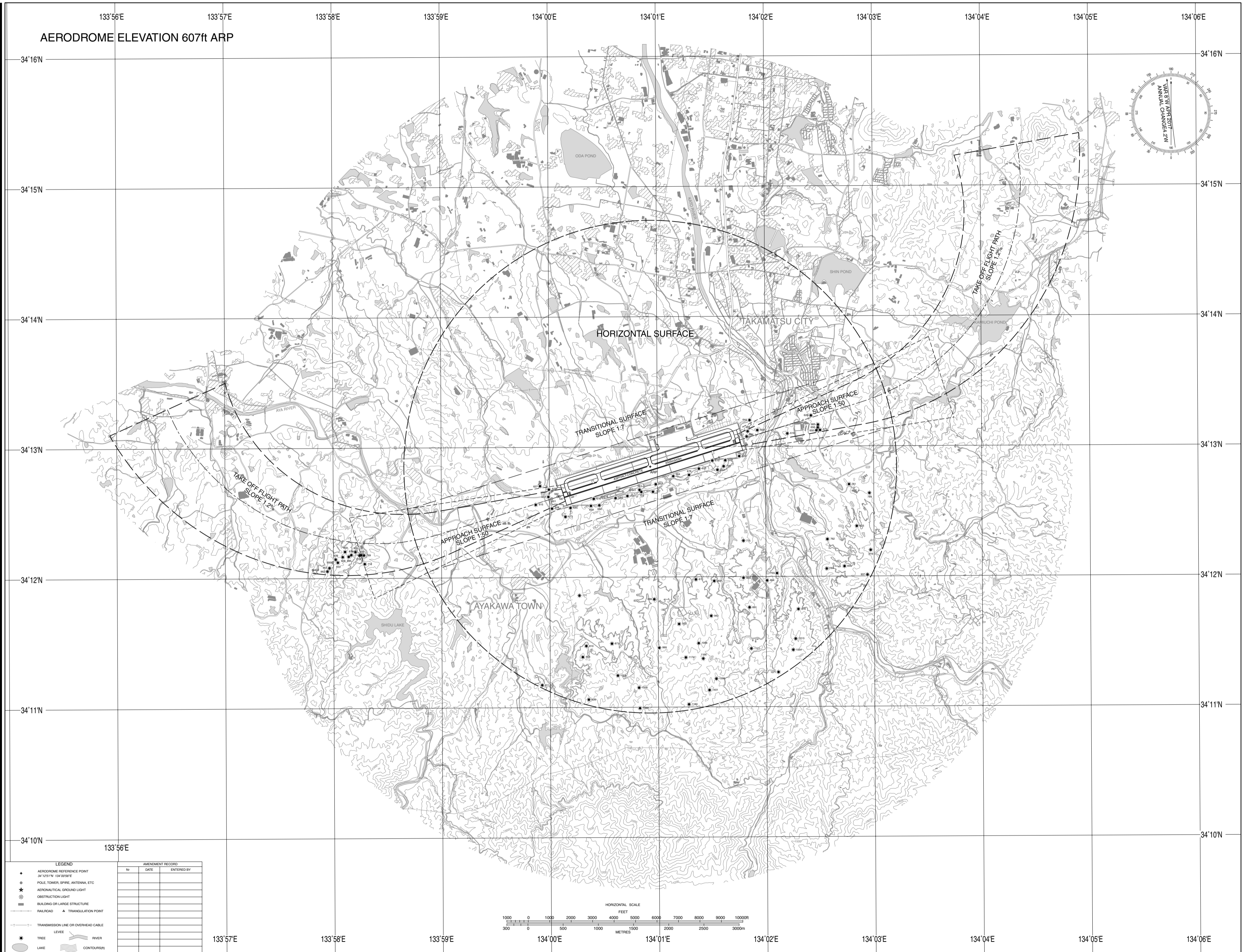

LEGEND		AMENDMENT RECORD		
+	AERODROME REFERENCE POINT 34°12'51"N 134°00'56"E	No.	DATE	ENTERED BY
⊙	POLE, TOWER, SPIRE, ANTENNA, ETC.			
★	AERONAUTICAL OBSTRUCTION LIGHT			
✳	OBSTRUCTION LIGHT			
■	BUILDING OR LARGE STRUCTURE			
—+—	RAILROAD			
—▲—	TRIANGULATION POINT			
— — —	TRANSMISSION LINE OR OVERHEAD CABLE			
— —	LEVEE			
— — —	RIVER			
○	LAKE			
— — —	CONTOUR(S)			

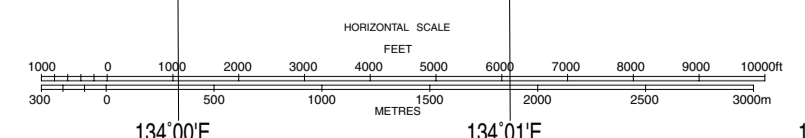

STANDARD ARRIVAL CHART-INSTRUMENT

RJOT / TAKAMATSU

STAR

KAGAWA ARRIVAL

From over WIMPY, via KTE R058 to KTE VOR/DME.  
Cross KTE VOR/DME at or above 5000FT.

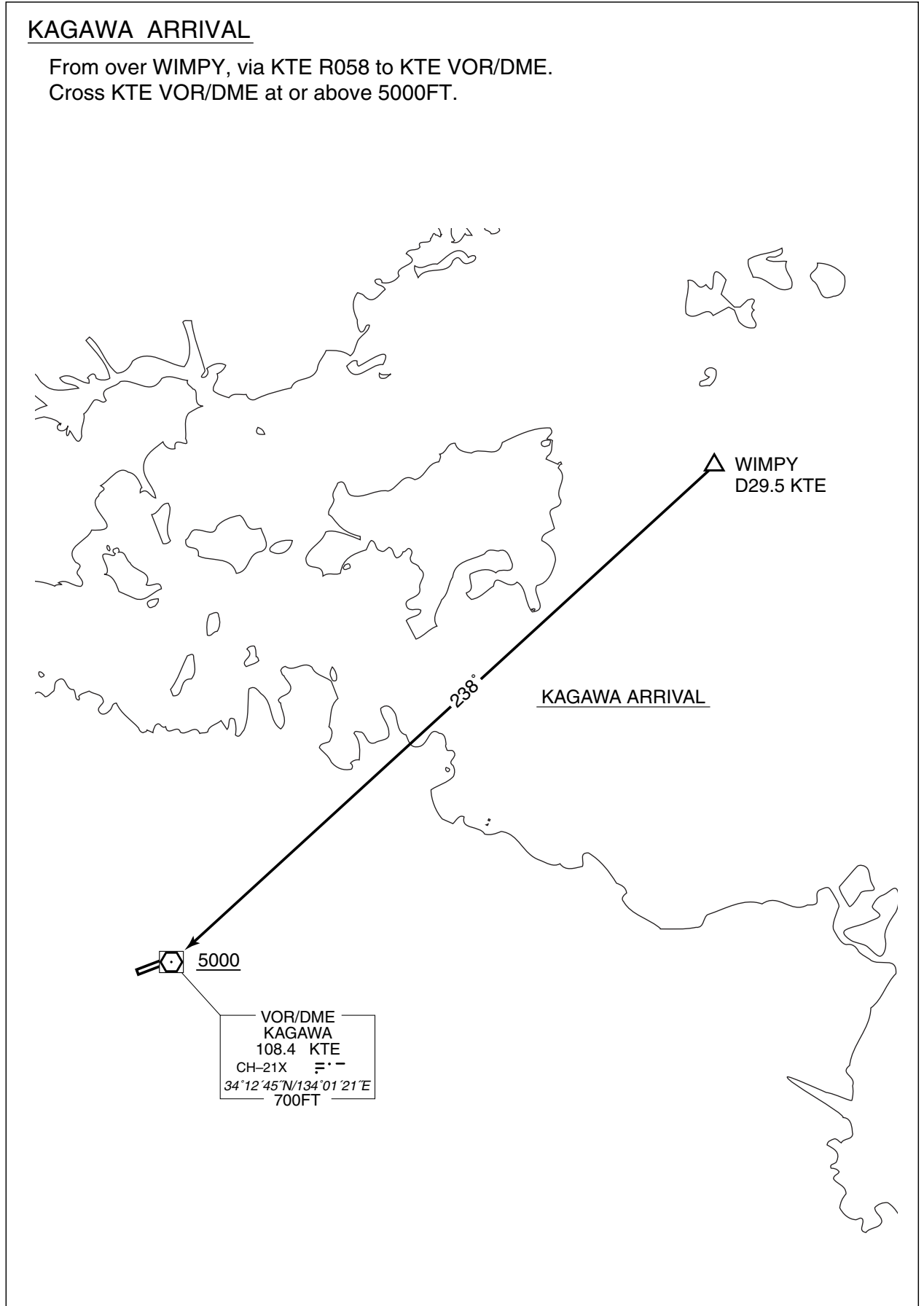

STANDARD ARRIVAL CHART-INSTRUMENT

RJOT / TAKAMATSU

RNAV STAR RWY26

POPAI ARRIVAL

RNAV1

Note 1) DME/DME/IRU or GNSS required.  
2) RADAR service required.

VAR 8°W (2018)

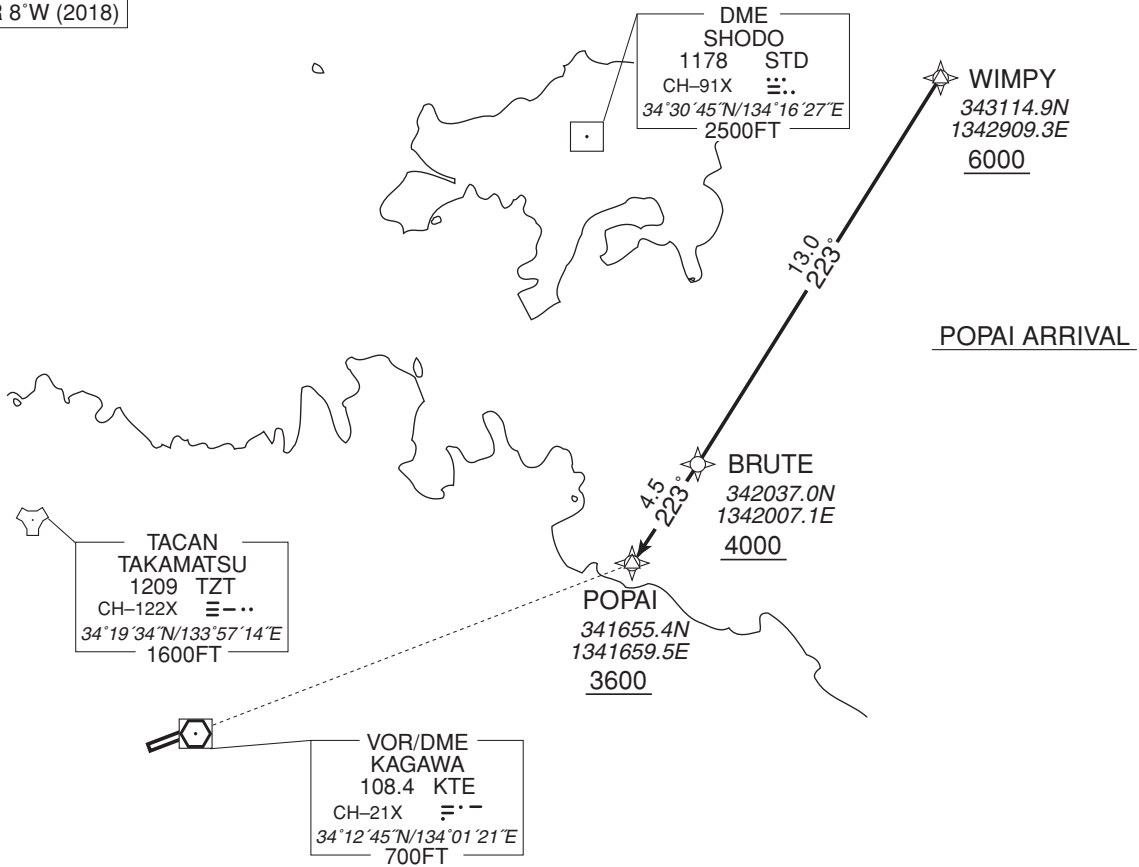

POPAI ARRIVAL

From WIMPY at or above 6000FT, to BRUTE at or above 4000FT, to POPAI at or above 3600FT.

Critical DME	-
DME GAP	-
Inappropriate Nav aids	See AD1.1.6.10.3. Inappropriate NAVAIDs for RNAV1

Serial Number	Path Descriptor	Waypoint Identifier	Fly Over	Course °M(°T)	Magnetic Variation	Distance (NM)	Turn Direction	Altitude (FT)	Speed (KIAS)	Vertical Angle	Navigation Specification
001	IF	WIMPY	-	-	-7.6	-	-	+6000	-	-	RNAV1
002	TF	BRUTE	-	223 (215.1)	-7.6	13.0	-	+4000	-	-	RNAV1
003	TF	POPAI	-	223 (215.0)	-7.6	4.5	-	+3600	-	-	RNAV1

CHANGE : VAR, POPAI

RJOT / TAKAMATSU

Minimum Vectoring Altitude CHART

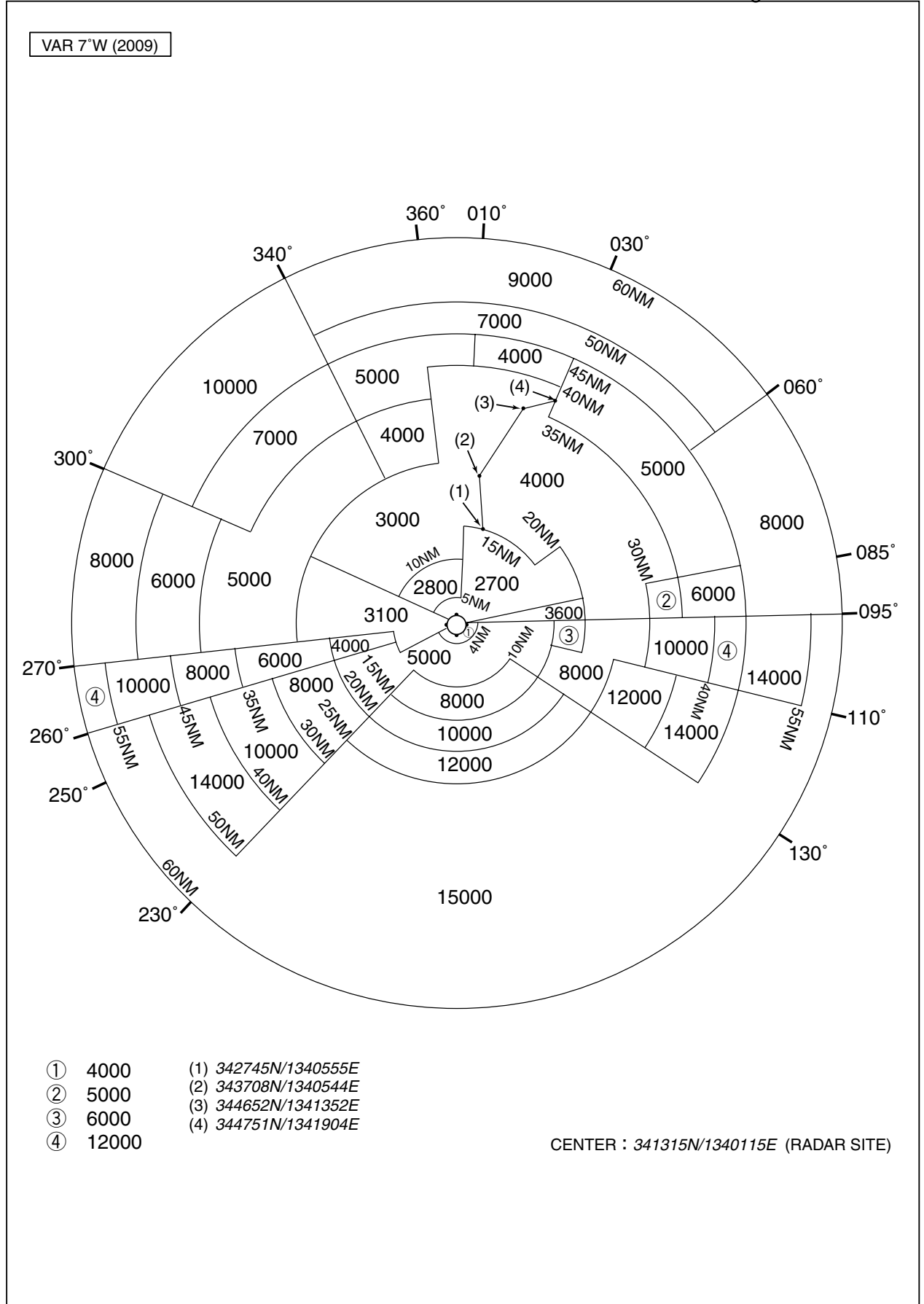



INSTRUMENT APPROACH CHART

RJOT / TAKAMATSU

VOR A

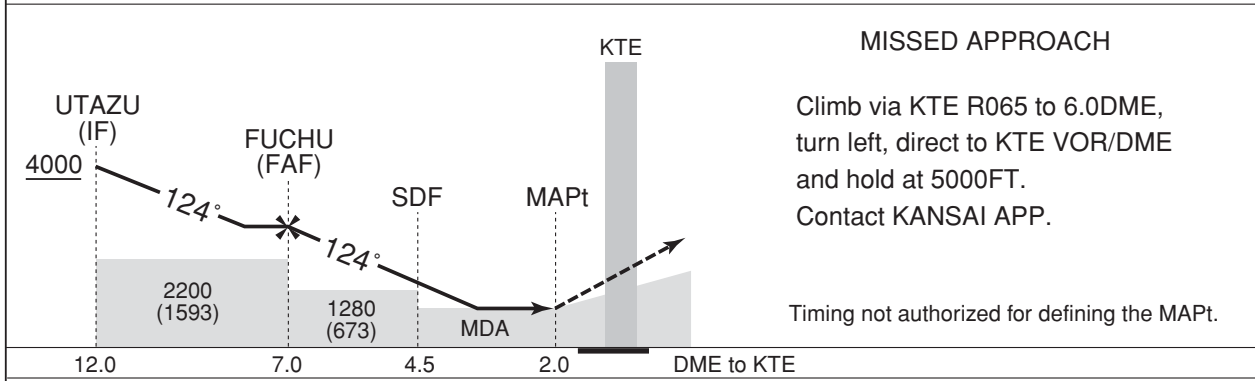
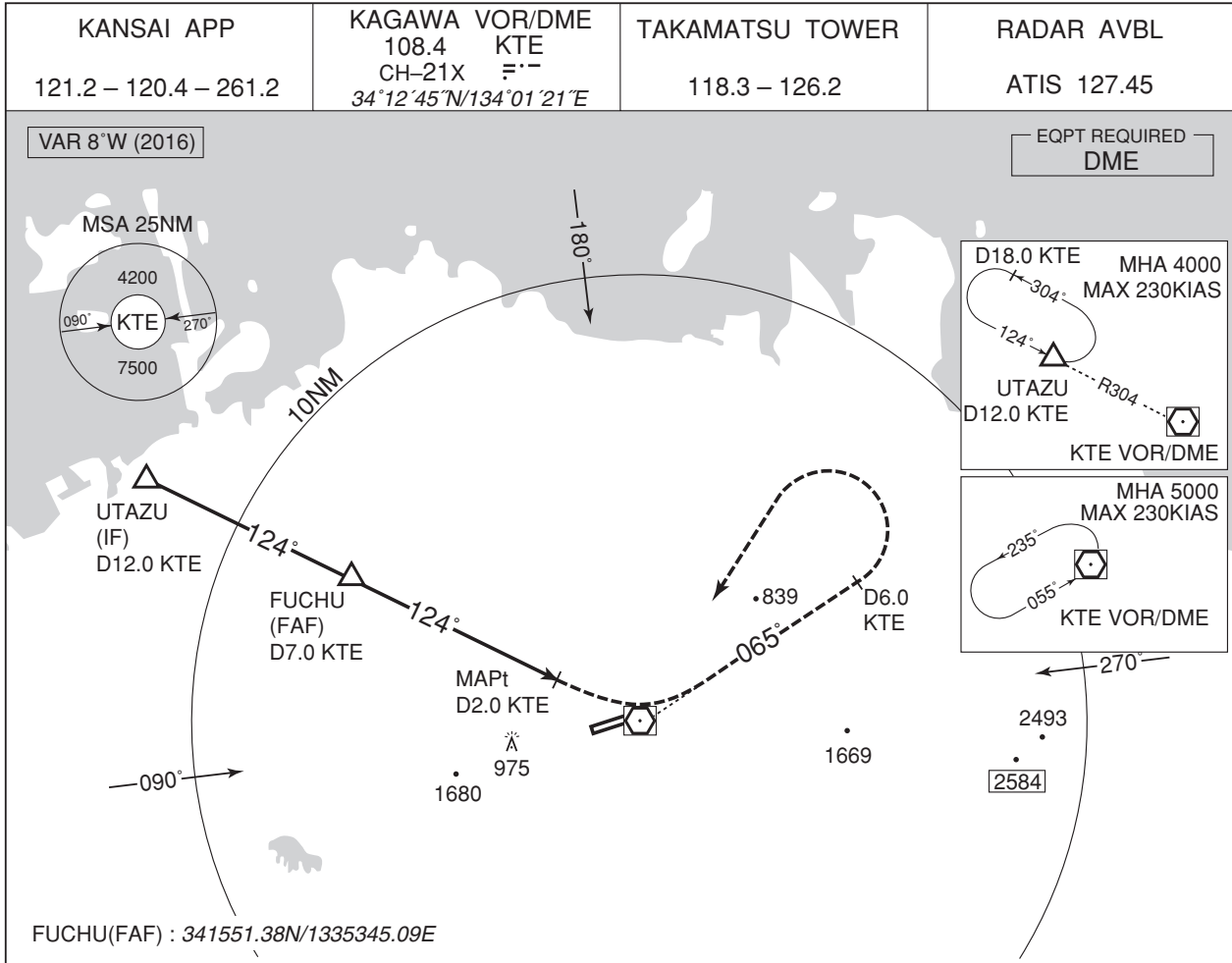

Missed APCH climb gradient MNM 5.0%

<b>MINIMA</b>		AD elev. 607
CAT	CIRCLING	
	MDA(H)	VIS
A	1060 (453)	1600
B		2400
C	1280 (673)	3200
D		

MINIMA with Missed APCH climb gradient of 2.5% are not established.  
Circling to NORTH side of RWY only.

CHANGE : MSA

AERODROME OBSTACLE CHART-ICAO  
TYPE A (OPERATING LIMITATIONS)

DIMENSIONS AND ELEVATIONS IN FEET BEARINGS ARE MAGNETIC

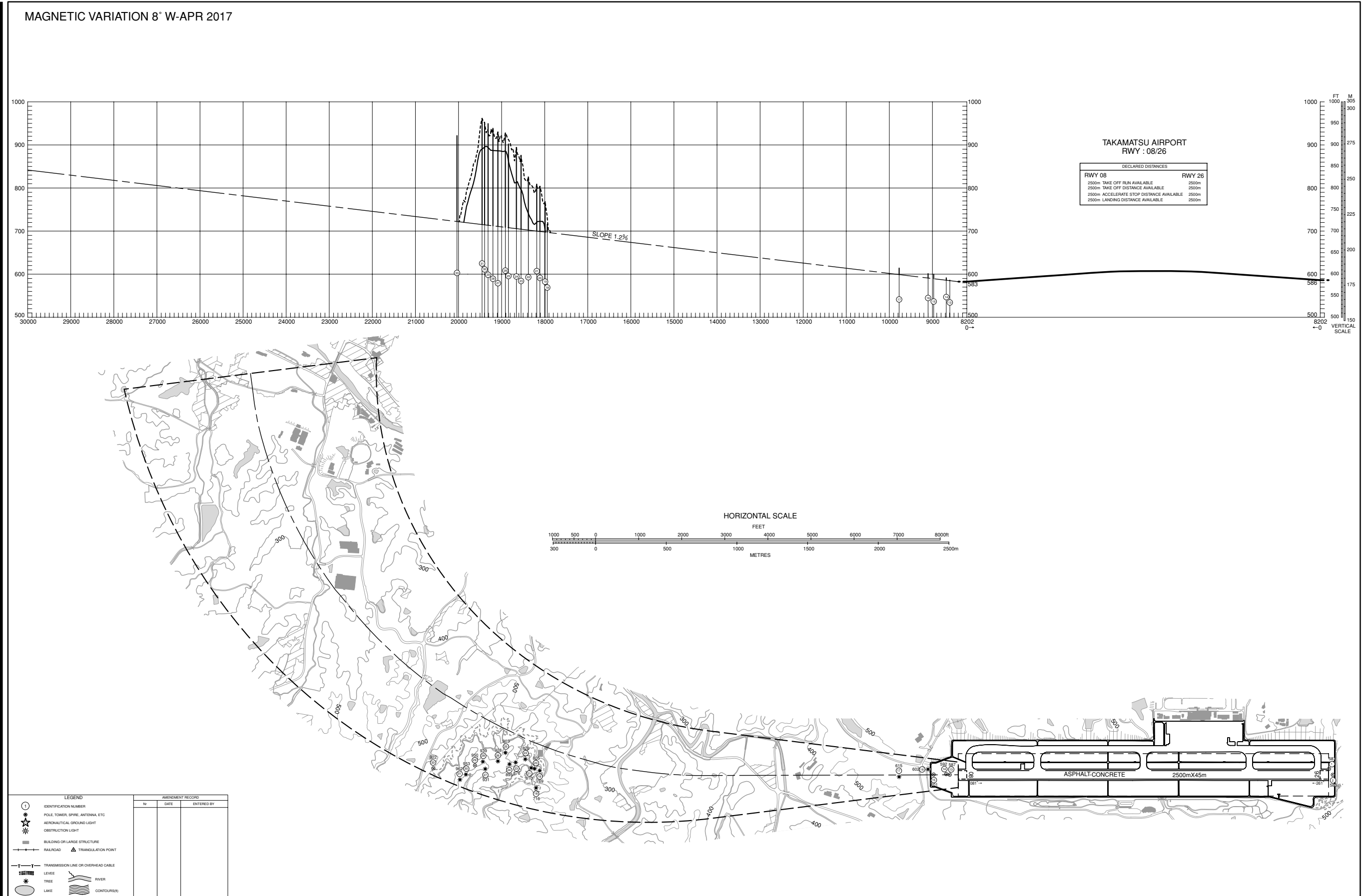

AERODROME OBSTACLE CHART-ICAO  
TYPE A (OPERATING LIMITATIONS)

DIMENSIONS AND ELEVATIONS IN FEET BEARINGS ARE MAGNETIC

MAGNETIC VARIATION 8° W-APR 2017

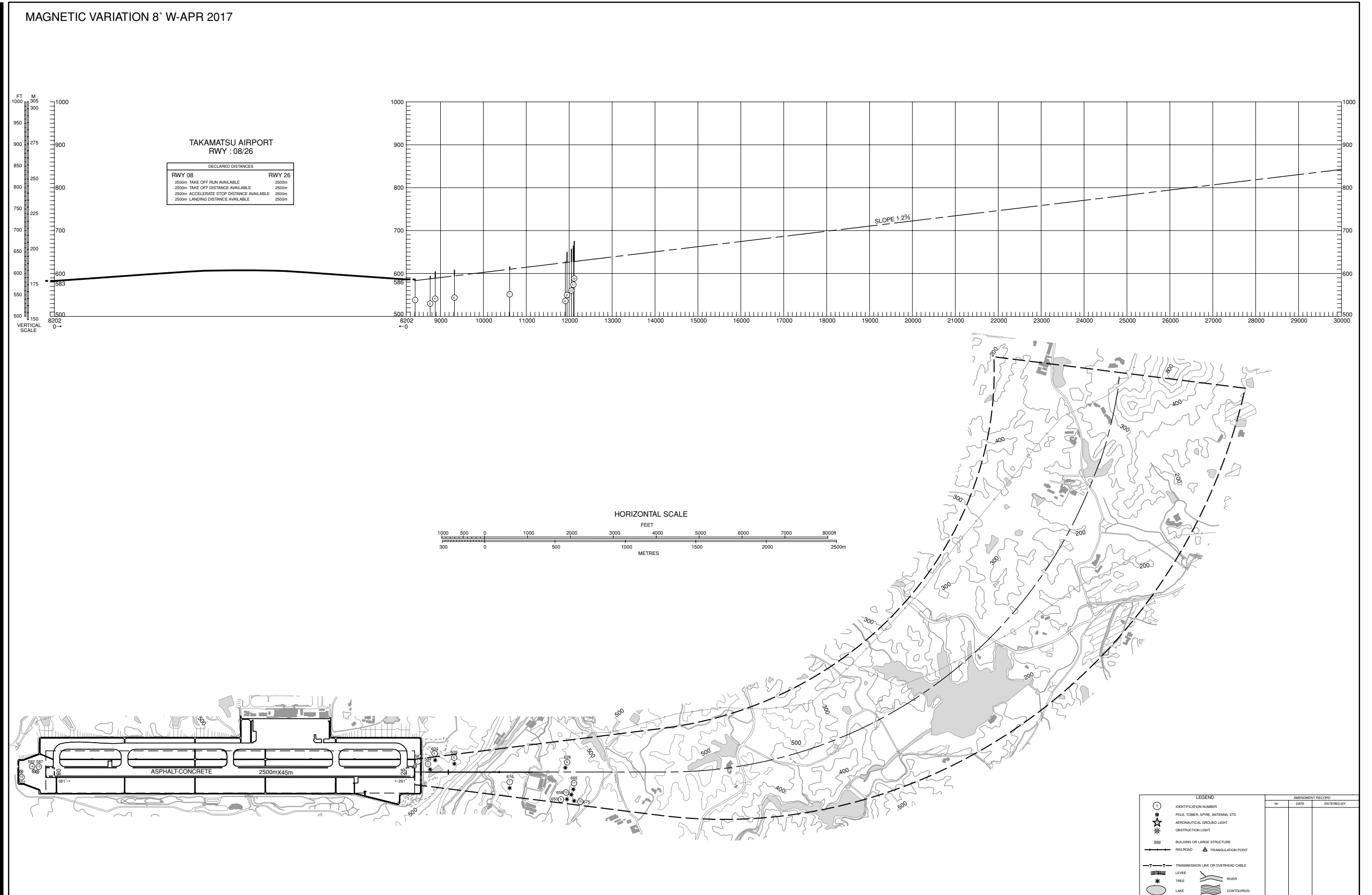

STANDARD DEPARTURE CHART-INSTRUMENT

RJOT / TAKAMATSU

SID

KAGAWA NORTH THREE DEPARTURE

RWY 08 : Climb RWY HDG to 1700FT, turn left HDG307° ...

RWY 26 : Climb RWY HDG to 2200FT, turn right HDG037° ...

...to intercept and proceed via KTE R352 to OYE VOR/DME.

Note : RWY 08 : 5.0% climb gradient required up to 1700FT.

OBST ALT 755FT located at 0.7NM 100° FM end of RWY08.

RWY 26 : 6.6% climb gradient required up to 2200FT.

OBST ALT 1772FT located at 3.3NM 255° FM end of RWY26.

KAGAWA REVERSAL EIGHT DEPARTURE

RWY 08 : Climb RWY HDG to 1700FT, turn left HDG322° ...

RWY 26 : Climb RWY HDG to 2200FT, turn right HDG052° ...

...to intercept and proceed via KTE R007 to 13.0DME, turn left  
direct to KTE VOR/DME.

Note : RWY 08 : 5.0% climb gradient required up to 1700FT.

OBST ALT 755FT located at 0.7NM 100° FM end of RWY08.

RWY 26 : 6.6% climb gradient required up to 2200FT.

OBST ALT 1772FT located at 3.3NM 255° FM end of RWY26.

STANDARD DEPARTURE CHART-INSTRUMENT

RJOT / TAKAMATSU

SID

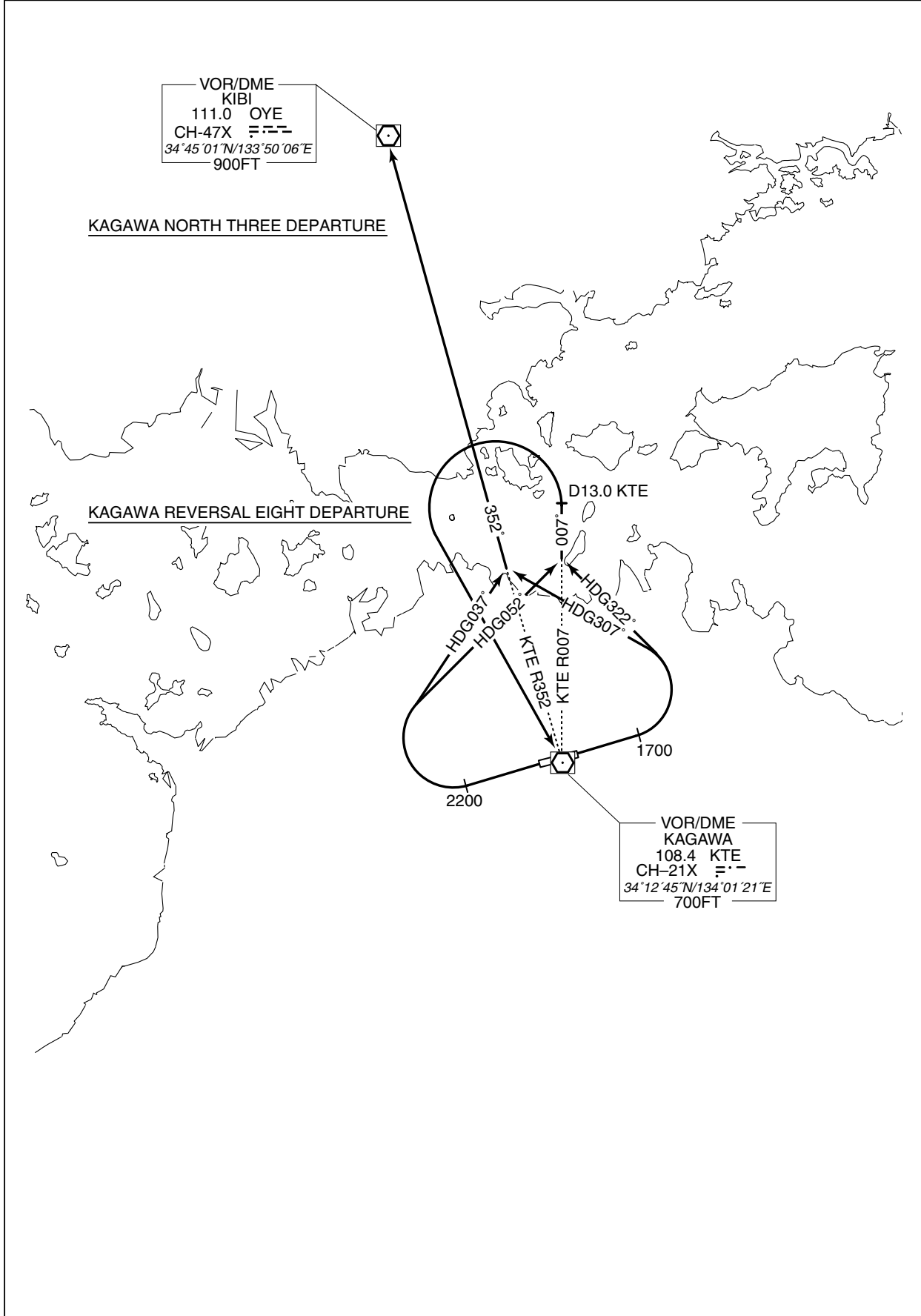

STANDARD DEPARTURE CHART-INSTRUMENT

RJOT / TAKAMATSU

RNAV SID and TRANSITION

OLIVE TWO DEPARTURE SHTLE TRANSITION		RNAV 1
Note 1 ) DME/DME/IRU or GNSS required. ※The aircraft equipped with only DME/DME/IRU must be able to update its position without delay at the starting point of take-off roll. 2 ) RADAR service required.	Critical DME	RWY08 STD : DER – 1NM from DER RWY26 STD : DER – 2NM from DER SHTLE TRANSITION KCC : 35.0NM to SHTLE – 16.0NM to SHTLE YOE : 66.0NM to SHTLE – 63.0NM to SHTLE
	DME GAP	SHTLE TRANSITION 50.0NM to SHTLE – 45.0NM to SHTLE
	Inappropriate Nav aids	See AD1.1.6.10.3. Inappropriate NAVAIDs for RNAV1

VAR 8° W(2020)

CHANGE : VAR. SID renamed. PROC course. Critical DME. DME GAP. HYOGO(FIX symbol).

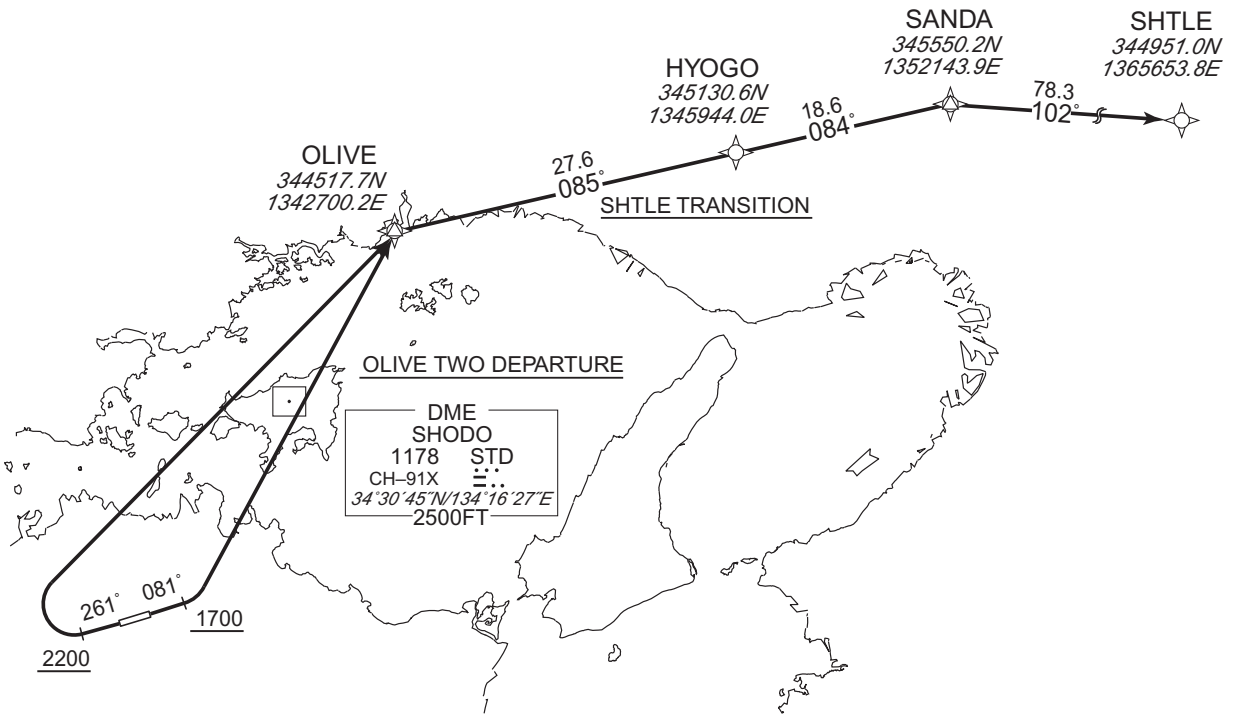

OLIVE TWO DEPARTURE

RWY08 : Climb on HDG 081° at or above 1700FT, turn left direct to OLIVE.  
 RWY26 : Climb on HDG 261° at or above 2200FT, turn right direct to OLIVE.

NOTE RWY08: 5.0% climb gradient required up to 1700FT.  
 OBST ALT 755FT located at 0.7NM 100° FM end of RWY08.  
 RWY26: 6.6% climb gradient required up to 2200FT.  
 OBST ALT 1772FT located at 3.3NM 255° FM end of RWY26.

SHTLE TRANSITION

From OLIVE, to HYOGO, to SANDA, to SHTLE.

## STANDARD DEPARTURE CHART-INSTRUMENT

RJOT / TAKAMATSU

RNAV SID and TRANSITION

OLIVE TWO DEPARTURE

## RWY08

Serial Number	Path Descriptor	Waypoint Identifier	Fly Over	Course °M(°T)	Magnetic Variation	Distance (NM)	Turn Direction	Altitude (FT)	Speed (KIAS)	Vertical Angle	Navigation Specification
001	VA	—	—	081 (072.9)	-7.8	—	—	+1700	—	—	RNAV1
002	DF	OLIVE	—	—	-7.8	—	L	—	—	—	RNAV1

## RWY26

Serial Number	Path Descriptor	Waypoint Identifier	Fly Over	Course °M(°T)	Magnetic Variation	Distance (NM)	Turn Direction	Altitude (FT)	Speed (KIAS)	Vertical Angle	Navigation Specification
001	VA	—	—	261 (252.9)	-7.8	—	—	+2200	—	—	RNAV1
002	DF	OLIVE	—	—	-7.8	—	R	—	—	—	RNAV1

SHTLE TRANSITION

Serial Number	Path Descriptor	Waypoint Identifier	Fly Over	Course °M(°T)	Magnetic Variation	Distance (NM)	Turn Direction	Altitude (FT)	Speed (KIAS)	Vertical Angle	Navigation Specification
001	IF	OLIVE	—	—	-7.8	—	—	—	—	—	RNAV1
002	TF	HYOGO	—	085 (076.8)	-7.8	27.6	—	—	—	—	RNAV1
003	TF	SANDA	—	084 (076.4)	-7.8	18.6	—	—	—	—	RNAV1
004	TF	SHTLE	—	102 (093.9)	-7.8	78.3	—	—	—	—	RNAV1

CHANGE : VAR. SID renamed. PROC course.

INSTRUMENT APPROACH CHART

RJOT / TAKAMATSU

ILS Z or LOC Z RWY26

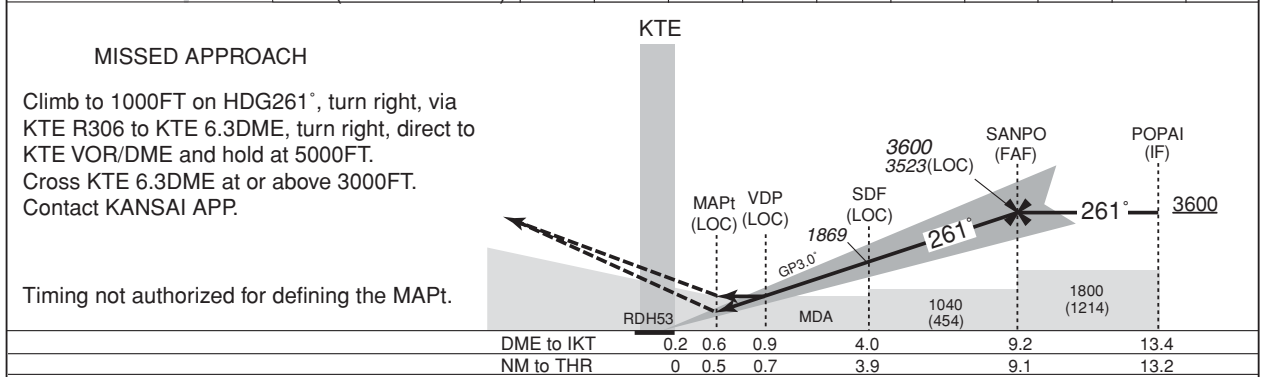
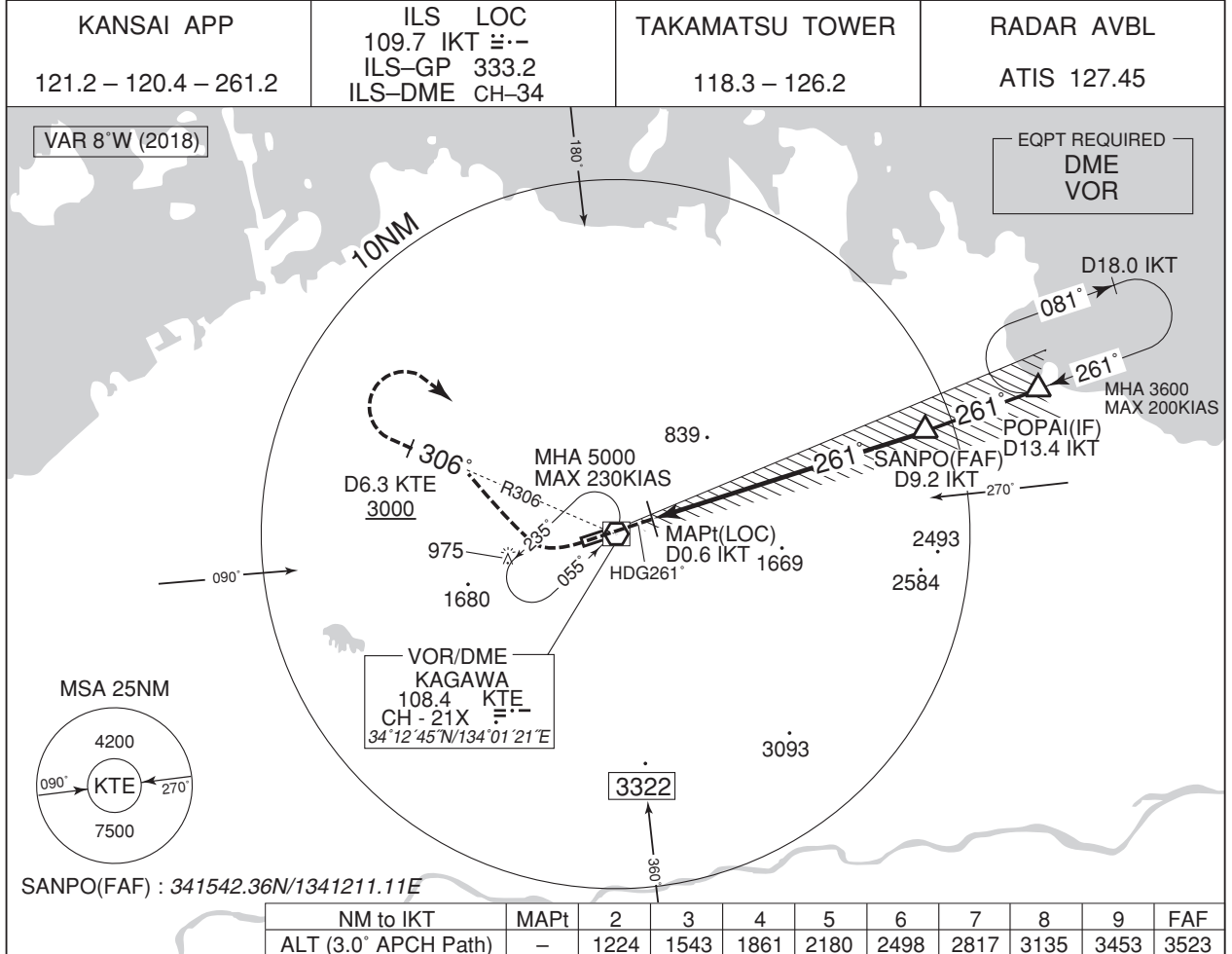

Missed APCH climb gradient MNM 5.0%

<b>MINIMA</b>		THR elev. 586		AD elev. 607		
CAT	CAT I		LOC		CIRCLING	
	DA(H)	RVR/CMV	MDA(H)	RVR/CMV	MDA(H)	VIS
A	786 (200)	550	920 (334)	900	1140 (533)	1600
B				1000		
C				1310 (703)	2400	
D				1400	1350 (743)	3200

Circling to NORTH side of RWY only.  
MINIMA with Missed APCH climb gradient of 2.5% are not established.



INSTRUMENT APPROACH CHART

RJOT / TAKAMATSU

ILS Y or LOC Y RWY26

KANSAI APP 121.2 – 120.4 – 261.2	ILS LOC 109.7 IKT ILS-GP 333.2 ILS-DME CH-34	TAKAMATSU TOWER 118.3 – 126.2	RADAR AVBL ATIS 127.45
-------------------------------------	---	----------------------------------	---------------------------

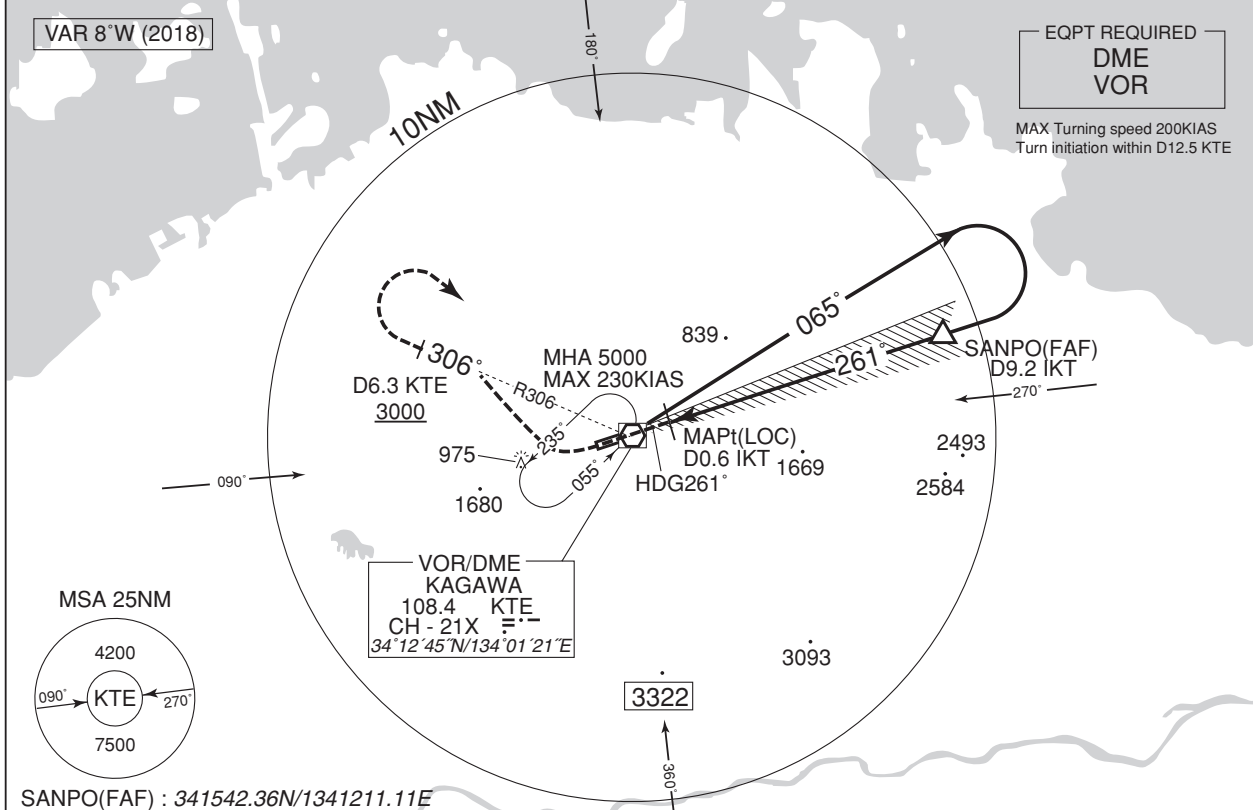

NM to IKT	MAPt	2	3	4	5	6	7	8	9	FAF
ALT (3.0° APCH Path)	-	1224	1543	1861	2180	2498	2817	3135	3453	3523

MISSED APPROACH

Climb to 1000FT on HDG261°, turn right, via KTE R306 to KTE 6.3DME, turn right, direct to KTE VOR/DME and hold at 5000FT.  
Cross KTE 6.3DME at or above 3000FT.  
Contact KANSAI APP.

Timing not authorized for defining the MAPt.

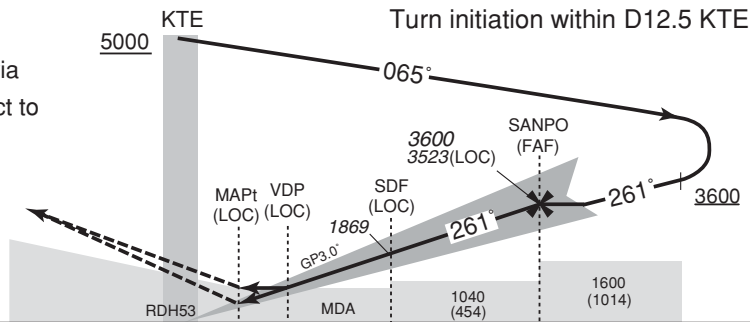

DME to IKT	0.2	0.6	0.9	4.0	9.2
NM to THR	0	0.5	0.7	3.9	9.1

Missed APCH climb gradient MNM 5.0%

MINIMA		THR elev. 586		AD elev. 607		
CAT	CAT I		LOC		CIRCLING	
	DA(H)	RVR/CMV	MDA(H)	RVR/CMV	MDA(H)	VIS
A	786 (200)	550	920 (334)	900	1140 (533)	1600
B				1000		
C				1310 (703)	2400	
D				1400	1350 (743)	3200

Circling to NORTH side of RWY only.  
MINIMA with Missed APCH climb gradient of 2.5% are not established.

CHANGE : HDG

INSTRUMENT APPROACH CHART

RJOT / TAKAMATSU

VOR RWY26

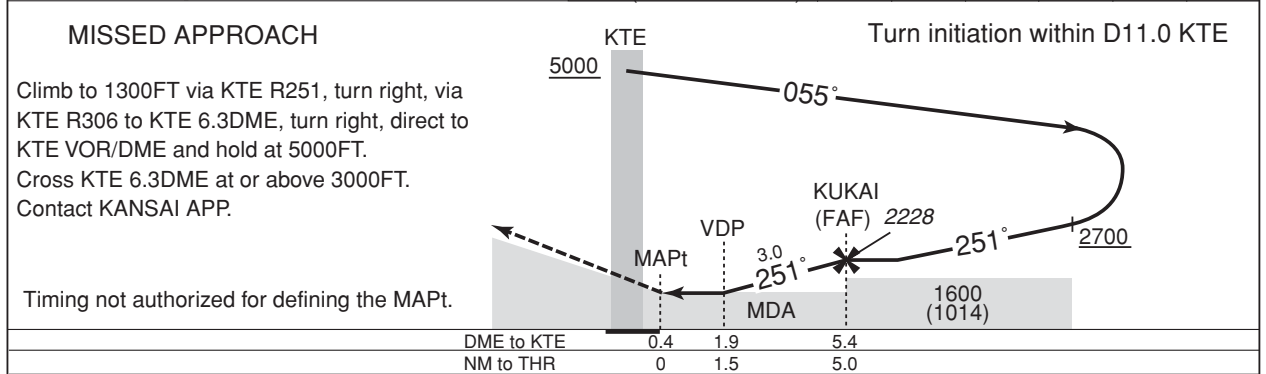
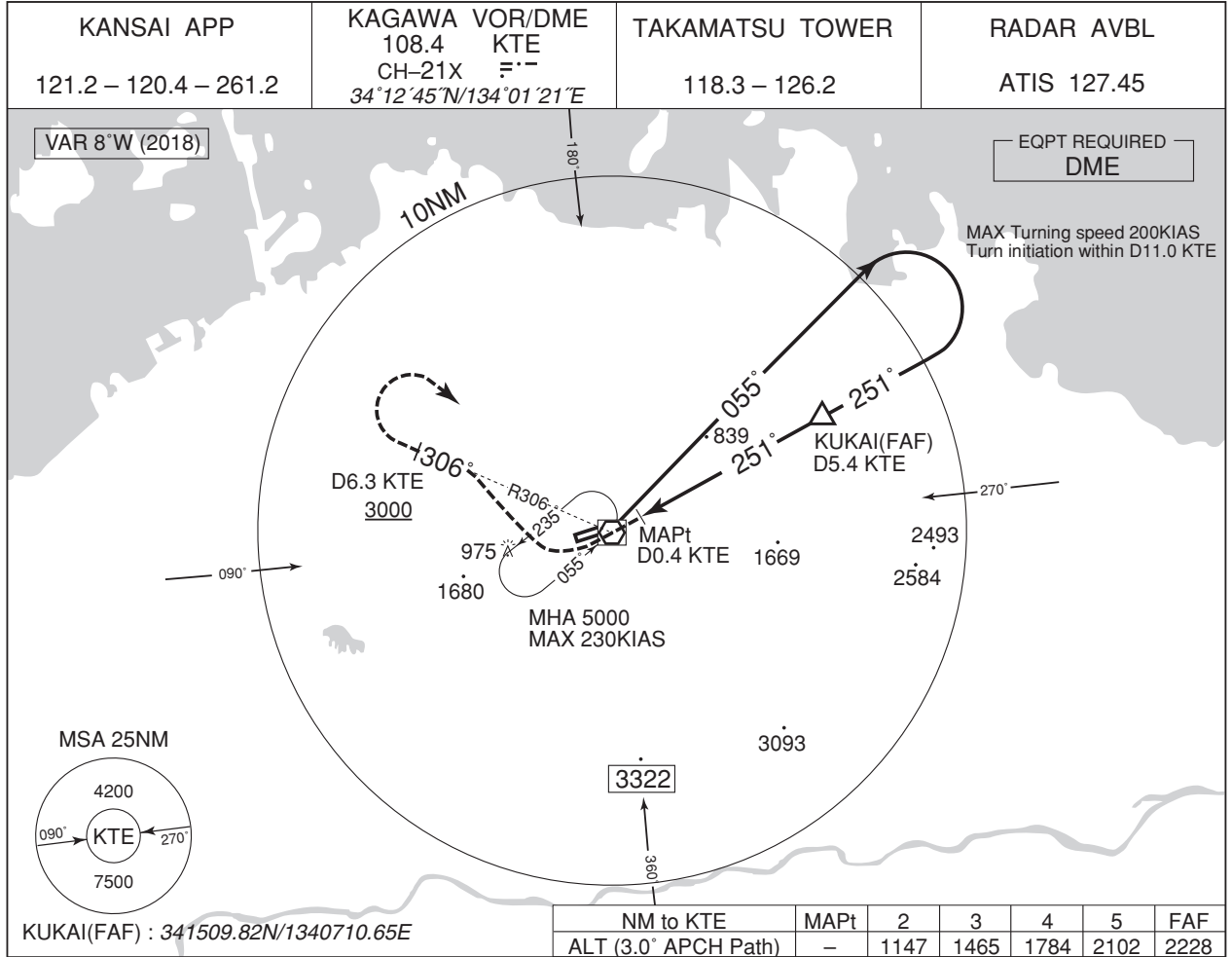

Missed APCH climb gradient MNM 5.0%

<b>MINIMA</b>		THR elev. 586	AD elev. 607	
CAT	MDA(H)	RVR/ CMV	CIRCLING MDA(H)    VIS	
A	1140 (554)	1000	1140 (533)    1600	
B		1200	1310 (703)    2400	
C		1600	1350 (743)	3200
D				

CHANGE : Update

Circling to NORTH side of RWY only.  
MINIMA with Missed APCH climb gradient of 2.5% are not established.

RJOT / TAKAMATSU

Visual REP

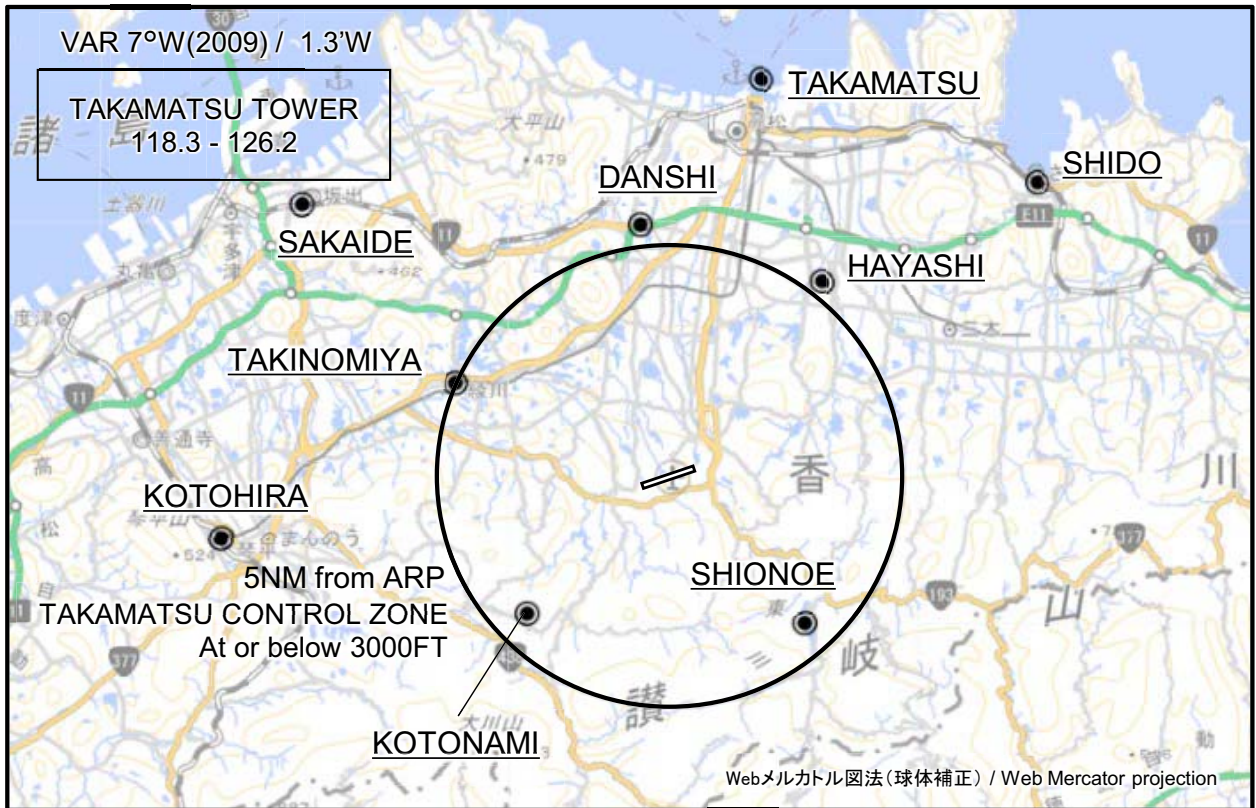

※図中に標高を示す数字がある場合、単位はメートル(m)である。The unit of measurement used to express elevation is meter(m).

CHANGE : Map updated. BRG/DIST from ARP. Danshi(Remarks).

Call sign	BRG / DIST from ARP	Remarks
高松 Takamatsu	012°T / 8.9NM	高松港 Harbor
志度 Shido	051°T / 10.1NM	JR志度駅 JR Station
坂出 Sakaide	307°T / 9.9NM	JR坂出駅 JR Station
檀紙 Danshi	353°T / 5.5NM	高松檀紙IC Interchange
林 Hayashi	037°T / 5.3NM	由良山 Mt. Yura
滝宮 Takinomiya	294°T / 5.1NM	琴平電鉄滝宮駅 Station
琴平 Kotohira	262°T / 9.8NM	JR琴平駅 JR Station
琴南 Kotonami	226°T / 4.3NM	四国電力開閉所 Switch station of Electric Power
塩江 Shionoe	138°T / 4.2NM	内場池 Pond of Naiba

注：有視界飛行方式により高松空港に着陸しようとする航空機又は高松航空交通管制圏を通過しようとする航空機は、東方向から進入する場合は、志度ポイント上空で、西方向から進入する場合は、坂出ポイント又は琴平ポイント上空で、北方向から進入する場合は、高松ポイント上空において高松タワーに連絡すること。

NOTE : When VFR flight is going to enter the control zone for landing or passing through, the pilot should contact with the control tower over;  
SHIDO in case of coming from east/  
SAKAIDE or KOTOHIRA in case of coming from west/  
TAKAMATSU in case of coming from north.

滑走路08側の進入角指示灯 (PAPI) の使用範囲は、障害物 (山及び樹木) のため滑走路08末端から約3.0NM以内とする。

Usable area of PAPI for Runway 08 is within approx 3.0NM from Runway 08 threshold.

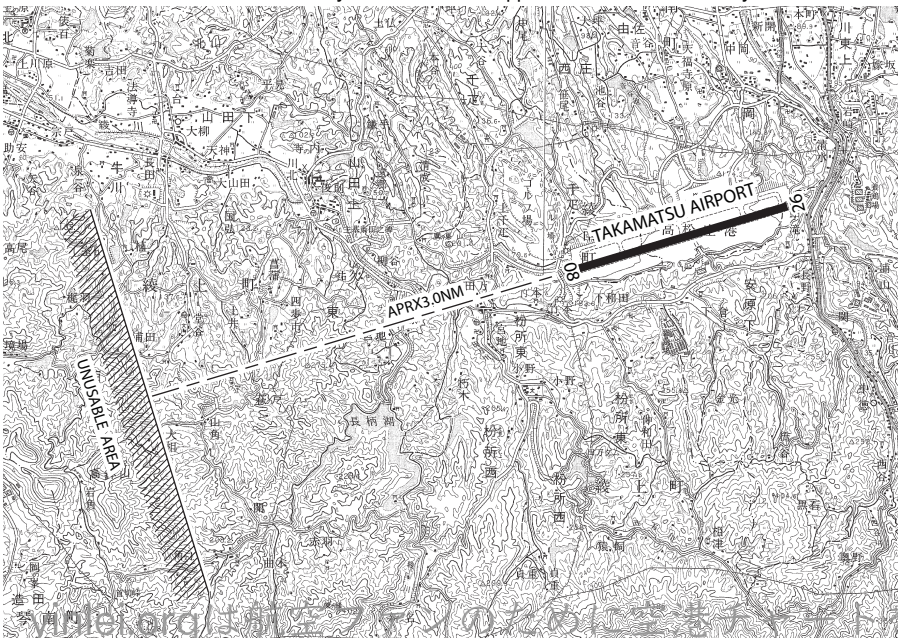

高松特別管制区  
Takamatsu Positive Control Area

NAME	LATERAL LIMITS	UPPER LIMIT (AMSL)	UNIT PROVIDING SERVICE	REMARKS
		LOWER LIMIT (AMSL) M(ft)		
1	2	3	4	5
高松 Takamatsu	下記に示される区域 The area shown below		Primary Kansai APP or Radar 121.2 MHz  Secondary Takamatsu TWR 118.3 MHz	当該空域を飛行しようとする航空機は、関西アプローチ又は高松タワーに連絡し、コールサイン、現在位置、高度及び意図を通報し指示を受けること。  Pilot of aircraft operating in this area shall contact Kansai Approach or Takamatsu Tower for ATC instructions giving informations on aircraft identification, positions, altitude and pilot's intentions.

TAKAMATSU POSITIVE CONTROL AREA

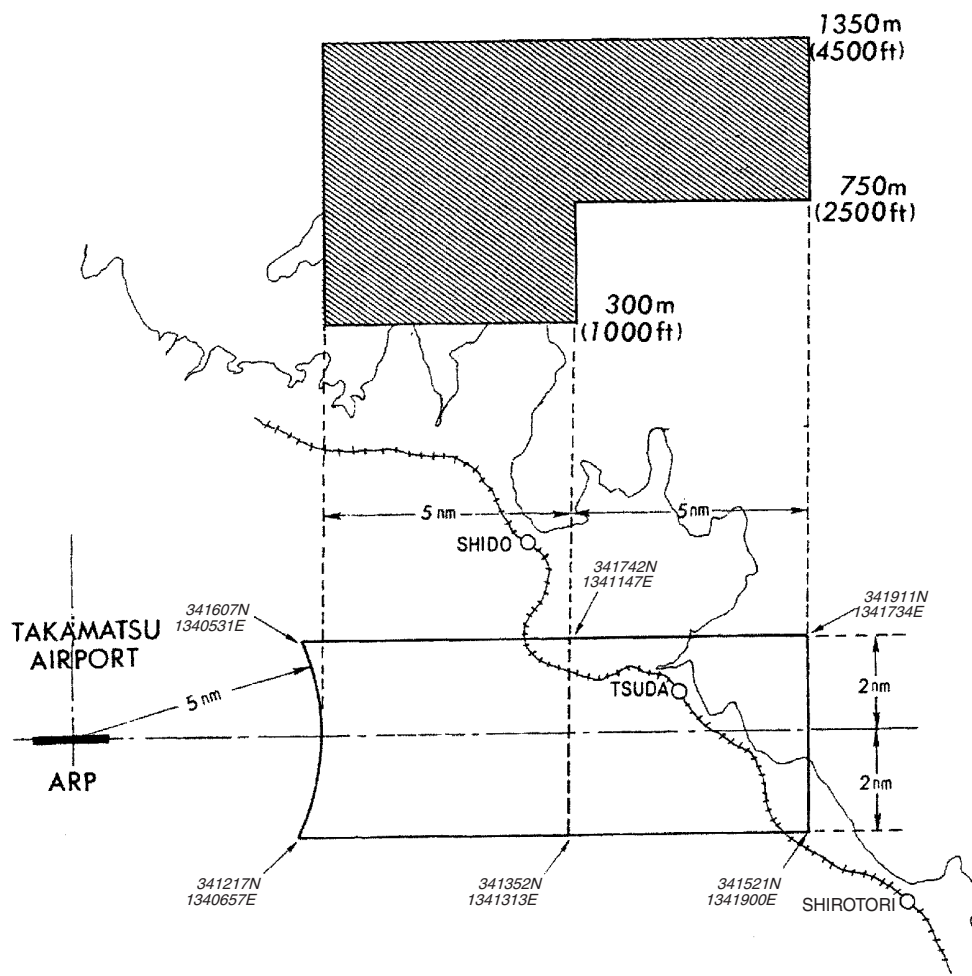

# TAKAMATSU AIRPORT

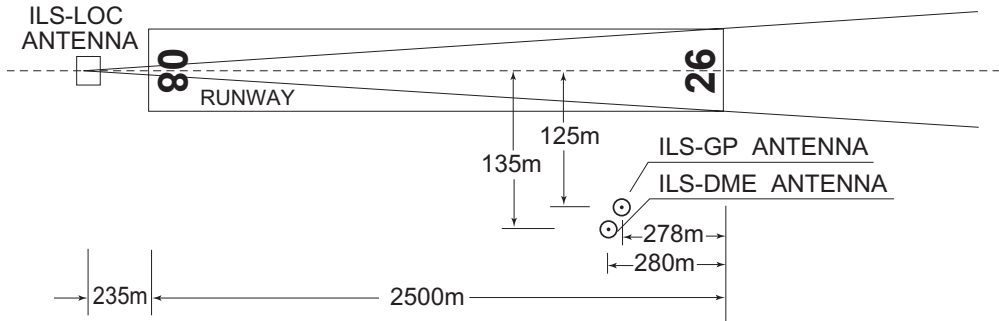

- REMARKS :
- |                         |               |
|-------------------------|---------------|
| 1. LOC beam BRG(MAG)    | 261°          |
| 2. HGT of ILS REF datum | 16.3m(53ft)   |
| 3. GP Angle             | 3.0°          |
| 4. ELEV of ILS-DME      | 183.9m(604ft) |

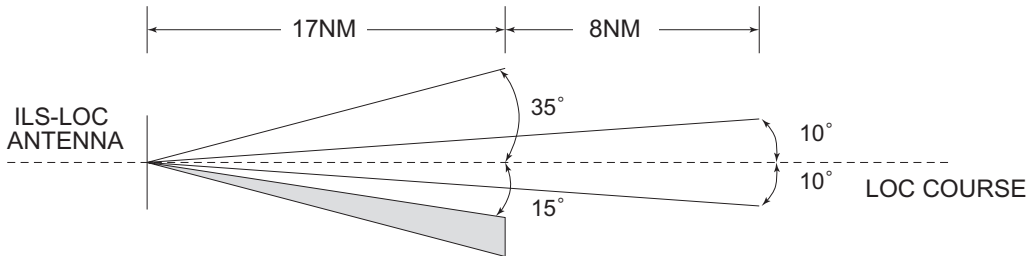

LOC Unusable beyond 15° South side of LOC course.