

## AD 2 AERODROMES

## RJOS AD 2.1 AERODROME LOCATION INDICATOR AND NAME

## RJOS - TOKUSHIMA

## RJOS AD 2.2 AERODROME GEOGRAPHICAL AND ADMINISTRATIVE DATA

1	ARP coordinates and site at AD	340756N/1343633E
2	Direction and distance from (city)	4NM ENE FM Tokushima
3	Elevation/ Reference temperature	37ft / -
4	Geoid undulation at AD ELEV PSN	Nil
5	MAG VAR/ Annual change	7° W(2010)/ -
6	AD Administration, address, telephone, telefax, telex, AFS, e-mail and/or Web-site addresses	Japan Maritime Self Defense Force. Public AD
7	Types of traffic permitted(IFR/ VFR)	IFR/VFR
8	Remarks	Tokushima Airport Office(CAB) 16-2 Aza Asahino Toyohisa Matsushige-cho Itano-gun Tokushima Pref Tel : 088-699-6527 Fax : 088-699-4470

## RJOS AD 2.3 OPERATIONAL HOURS

1	AD Administration	H24
2	Customs and immigration	On request Customs: 0885-32-0326 Immigration: 0885-32-1530
3	Health and sanitation	On request Quarantine(human): 0877-46-4279 Quarantine(animal): 087-879-4654 Quarantine(plant): 0885-32-1227
4	AIS Briefing Office	H24(CAB:Nil)
5	ATS Reporting Office(ARO)	Nil
6	MET Briefing Office	H24(KANSAI)
7	ATS	H24
8	Fuelling	2100-1030
9	Handling	2100-1100
10	Security	Nil
11	De-icing	Nil
12	Remarks	HR of service at CAB OPS Section: 2200 - 1230(Daily)

**RJOS AD 2.4 HANDLING SERVICES AND FACILITIES**

1	Cargo-handling facilities	Nil
2	Fuel/ oil types	JET A-1(CIV only) JP-5(JSDF only)
3	Fuelling facilities/ capacity	Fuel truck(CIV)
4	De-icing facilities	Nil
5	Hangar space for visiting aircraft	Nil
6	Repair facilities for visiting aircraft	Nil
7	Remarks	Nil

**RJOS AD 2.5 PASSENGER FACILITIES**

1	Hotels	Nil
2	Restaurants	At Airport
3	Transportation	Buses and Taxis
4	Medical facilities	Nil
5	Bank and Post Office	Nil
6	Tourist Office	Nil
7	Remarks	Nil

**RJOS AD 2.6 RESCUE AND FIRE FIGHTING SERVICES**

1	AD category for fire fighting	To be issued later
2	Rescue equipment	To be issued later
3	Capability for removal of disabled aircraft	To be issued later
4	Remarks	Nil

**RJOS AD 2.7 SEASONAL AVAILABILITY-CLEARING**

1	Types of clearing equipment	To be issued later
2	Clearance priorities	To be issued later
3	Remarks	Nil

**RJOS AD 2.8 APRONS, TAXIWAYS AND CHECK LOCATIONS DATA**

1	Apron surface and strength	NORTH APRON Surface : Concrete Strength : PCN 72/R/B/X/U
2	Taxiway width, surface and strength	Surface : Asphalt-concrete N-1(NORTH-1) Width : 28.5m, Strength : PCN 75/F/B/X/U SOUTH-1 Width : 23m, Strength : PCN 43/F/C/X/T N-2(NORTH-2), N-3(NORTH-3), N-4(NORTH-4), N-5(NORTH-5) Width : 34m, Strength : PCN 75/F/B/X/U SOUTH-2, SOUTH PARL TWY(BTN SOUTH-2 and SOUTH-5) Width : 23m, Strength : PCN 40/F/C/X/T SOUTH-3 Width : 23m, Strength : PCN 25/F/C/Y/T SOUTH-4, SOUTH-5 Width : 23m, Strength : PCN 41/F/A/X/T N-6(NORTH-6) Width : 28.5m PCN 70/F/A/X/U SOUTH-6, SOUTH PARL TWY(BTN SOUTH-5 and SOUTH-6) Width : 18m, Strength : PCN 28/F/A/Y/T NORTH PARL TWY(BTN N-1(NORTH-1) and N-5(NORTH-5) ) Width : 23m, Strength : PCN 75/F/B/X/U NORTH PARL TWY(BTN N-5(NORTH-5) and N-6(NORTH-6) ) Width : 23m, Strength : PCN 70/F/A/X/U  Surface : Concrete SOUTH PARL TWY(BTN WEST SIDE END and SOUTH-2) Width : 18m, Strength : To be issued later
3	ACL and elevation	Not available
4	VOR checkpoints	Nil
5	INS checkpoints	To be issued later
6	Remarks	Nil

**RJOS AD 2.9 SURFACE MOVEMENT GUIDANCE AND CONTROL SYSTEM AND MARKINGS**

1	Use of aircraft stand ID signs, TWY guide lines and Visual docking/ parking guidance system of aircraft stands	Nil
2	RWY and TWY markings and LGT	RWY:11/29 (Marking) RWY designation, RWY CL, RWY THR, TDZ, RWY side stripe (LGT) RCLL, REDL, RTHL, RENL, WBAR, RWY DIST marker, TKOF aiming LGT  TWY: (Marking) TWY CL, RWY HLDG PSN, TWY side stripe, Mandatory instruction (LGT) TWY edge LGT, TWY CL LGT(N-1(NORTH-1) THRU N-6(NORTH-6) AND NORTH PARL TWY), Taxiing guidance sign(N-1(NORTH-1) THRU N-6(NORTH-6))
3	Stop bars	Nil
4	Remarks	(Marking) Overrun area (LGT) APN flood LGT

## RJOS AD 2.10 AERODROME OBSTACLES

In approach / TKOF Areas

RWY/Area affected	Obstacle type	Coordinates	Elevation	Markings / LGT	Remarks
RWY29	Antenna	340608.2N1343549.5E	296FT	Marking / LIM, LIL	Nil

In circling area and at AD

Obstacle type	Coordinates	Elevation	Markings/ LGT	Remarks
Nil				

## RJOS AD 2.11 METEOROLOGICAL INFORMATION PROVIDED

1	Associated MET Office	KANSAI
2	Hours of service MET Office outside hours	H24(KANSAI)
3	Office responsible for TAF preparation Periods of validity	Nil
4	Trend forecast Interval of issuance	Nil
5	Briefing/ consultation provided	Briefing is available upon inquiry at KANSAI
6	Flight documentation Language(s) used	Nil
7	Charts and other information available for briefing or consultation	S <sub>6</sub> , U <sub>85</sub> , U <sub>7</sub> , U <sub>5</sub> , U <sub>3</sub> , U <sub>25</sub> , U <sub>2</sub> /T <sub>r</sub> , P <sub>S</sub> , P <sub>5</sub> , P <sub>3</sub> , P <sub>25</sub> , P <sub>SWE</sub> , P <sub>SWF</sub> , P <sub>SWG</sub> , P <sub>SWI</sub> , P <sub>SWM</sub> , P <sub>SW</sub> (domestic), E, C, W <sub>E</sub> , W <sub>F</sub> , W <sub>G</sub> , W <sub>I</sub> , W, N
8	Supplementary equipment available for providing information	Nil
9	ATS units provided with information	TWR, APP, ATIS
10	Additional information(limitation of service, etc.)	Observation is made by the Ministry of Defence.

**RJOS AD 2.12 RUNWAY PHYSICAL CHARACTERISTICS**

Designations RWY NR	TRUE BRG	Dimensions of RWY(M)	Strength(PCN) and surface of RWY	THR coordinates THR geoid undulation	THR elevation and highest elevation of TDZ of precision APP RWY
1	2	3	4	5	6
11	102.53°	2500×45	PCN 70/F/A/X/T SW90000kg (198400lbs) DW124000kg (273400lbs) DTW182000kg (401300lbs) TTTW216000kg (476200lbs) Asphalt-Concrete	Nil	THR EVEV : 6ft
29	282.53°	2500×45	PCN 70/F/A/X/T SW90000kg (198400lbs) DW124000kg (273400lbs) DTW182000kg (401300lbs) TTTW216000kg (476200lbs) Asphalt-Concrete	Nil	THR EVEV : 37ft TDZ ELEV : 37ft
Slope of RWY		Strip Dimensions(M)		Remarks	
7		10		12	
SEE AD2.24 AD chart		2760×300 2760×300		RWY Grooving 30×2500m	

**RJOS AD 2.13 DECLARED DISTANCES**

RWY Designator	TORA (m)	TODA (m)	ASDA (m)	LDA (m)	Remarks
1	2	3	4	5	6
11	2500	2500	2500	2500	Nil
29	2500	2500	2500	2500	Nil

## RJOS AD 2.14 APPROACH AND RUNWAY LIGHTING

RWY Designator	APCH LGT type LEN INTST	RTHL Color WBAR	PAPI (VASIS) Angle DIST FM THR MEHT	RTZL LEN	RCLL LEN Spacing Color INTST	REDL LEN Spacing Color INTST	RENL Color WBAR	STWL LEN Color
1	2	3	4	5	6	7	8	9
11	SALS (*1) 420m	Green -	PAPI 3.0°/Left 454m 73ft	Nil	2500M 30M Coded color (White/Red) LIH	2500M 60M Coded color (White/Yellow) LIH	Red	Nil(*2)
29	Nil	Green Green	PAPI 3.0°/Left 488m 65.6ft	Nil	2500M 30M Coded color (White/Red) LIH	2500M 60M Coded color (White/Yellow) LIH	Red	Nil(*2)
Remarks								
10								
SALS with APCH LGT beacon (600m and 841m FM RWY 11 THR) (*1) Overrun area edge LGT(Color: Red)(*2) CGL for RWY 11(Color: Yellow) RWY THR ID LGT for RWY 11/29 THR(Color: White)								

## RJOS AD 2.15 OTHER LIGHTING, SECONDARY POWER SUPPLY

1	ABN/IBN location, characteristics and hours of operation	ABN: 340752N/1343546E, White/Green EV 4.3sec, HO
2	LDI location and LGT Anemometer location and LGT	LDI : AVBL
3	TWY edge and center line lighting	TWY edge and center line lights installed, see AD2.9
4	Secondary power supply/ switch-over time	Within 15 sec: TWY edge LGT(TWY N-1(NORTH-1) THRU N-6(NORTH-6), NORTH PARL) TWY CL LGT(TWY N-1(NORTH-1) THRU N-6(NORTH-6), NORTH PARL), Apron flood LGT(CIV)
5	Remarks	WDI LGT, OBST LGT

## RJOS AD 2.16 HELICOPTER LANDING AREA

Nil
-----

RJOS AD 2.17 ATS AIRSPACE

Designation and lateral limits		Vertical limits (ft)	Airspace classification	ATS unit call sign Language	Remarks
1		2	3	4	6
TOKUSHIMA CTR	Area within a radius of 5nm of TOKUSHIMA ARP (34°08'N/134°37'E)	5000 or below	D	Tokushima Tower En	
TOKUSHIMA ACA	See below figure		E	Tokushima Approach Tokushima Departure Tokushima Radar En	

徳島進入管制区  
Tokushima Approach Control Area

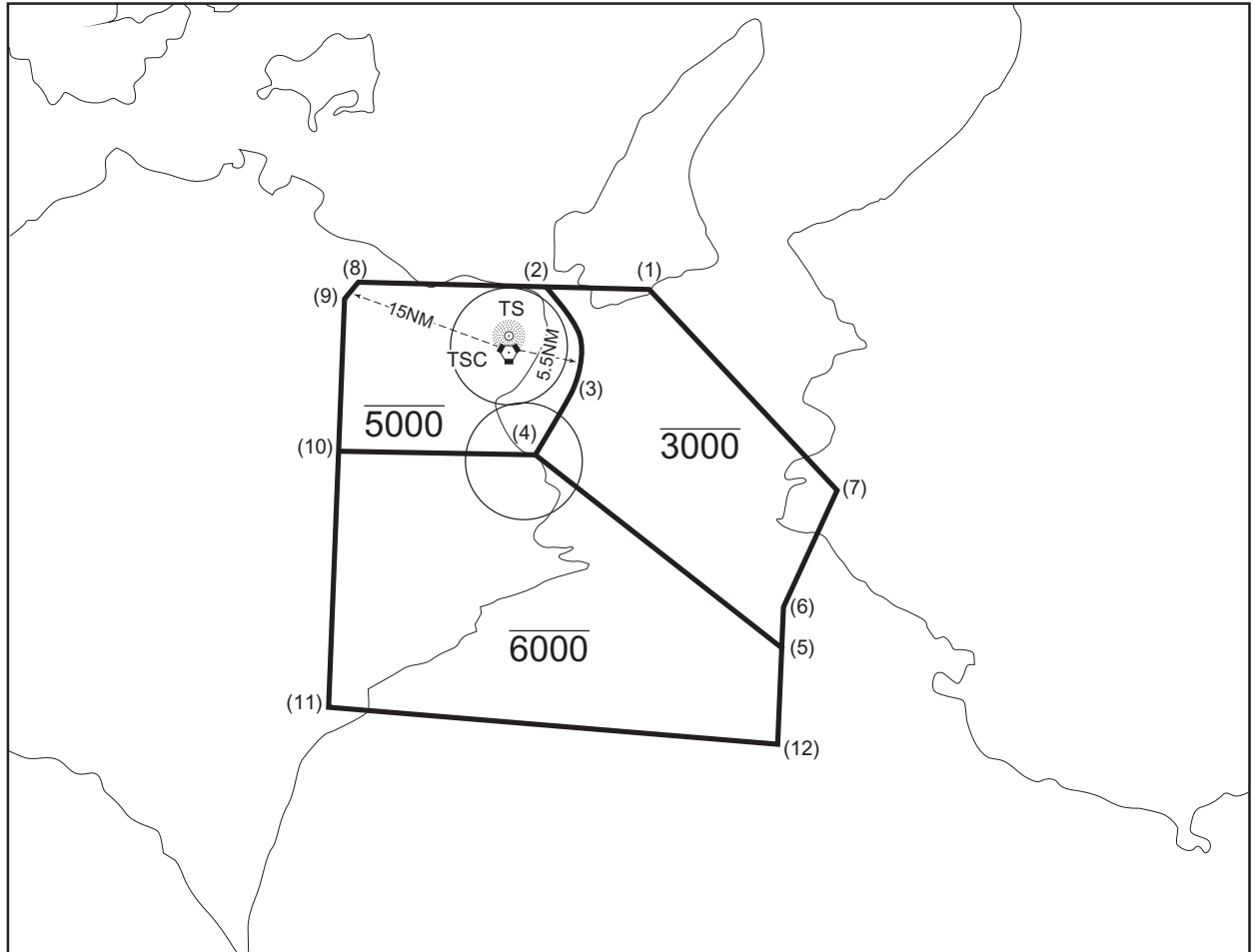

Point list

- |                      |                       |
|----------------------|-----------------------|
| (1) 341300N/1345028E | (7) 335551N/1350941E  |
| (2) 341300N/1343838E | (8) 341300N/1341932E  |
| (3) 340527N/1344232E | (9) 341136N/1341900E  |
| (4) 335837N/1343856E | (10) 335801N/1341900E |
| (5) 334323N/1350500E | (11) 333545N/1341900E |
| (6) 334636N/1350500E | (12) 333338N/1350500E |

## RJOS AD 2.18 ATS COMMUNICATION FACILITIES

Service designation	Call sign	Frequency	Hours of operation	Remarks
1	2	3	4	5
TWR	Tokushima Tower	236.8MHz 126.2MHz(1) 233.8MHz 118.0MHz 123.1MHz(2) 243.0MHz(E) 121.5MHz(E)	H24	(1) Primary (2) For rescue only (3) AVBL on request
GND	Tokushima Ground	233.8MHz 118.0MHz	H24	
DEP/ASR	Tokushima Departure /Tokushima Radar	284.6MHz 124.0MHz(1) 120.1MHz 261.2MHz 362.3MHz 122.45MHz(3) 126.2MHz(3) 228.2MHz(3) 121.5MHz(E) 243.0MHz(E)	2200 - 1230 Other time 1HR PN	
APP	Tokushima Approach	284.6MHz 124.0MHz(1) 120.1MHz 261.2MHz 362.3MHz 122.45MHz(3) 126.2MHz(3) 228.2MHz(3) 121.5MHz(E) 243.0MHz(E)	H24(4)	(4) Terminal Rader SER 2200-1230. Other time 1 HR PN.
GCA-ASR -PAR	Tokushima Radar /Tokushima GCA	335.6MHz 270.8MHz 134.1MHz 125.3MHz 303.8MHz 258.6MHz 141.2MHz 139.55MHz 243.0MHz(E) 121.5MHz(E)	2200- 1230 Other time 1HR PN	ASR,PAR RWY 29 Glide path 3.0° Maintenance period: 2300-0300 FRI in VMC. Blind zone lies BTN 010°-050°,060°-070° 10nm ARC and weak zone lies 140° BTN 23-25nm BLW 1100ft FM ASR site (34°07'51"N 134°35'52"E).
ATIS	Tokushima Airport	246.8MHz	2300- 1100 EXC FRI1101- SUN2259 and HOL. Other time 1HR PN	



RJOS AD 2.19 RADIO NAVIGATION AND LANDING AIDS

Type of aid	ID	Frequency	Hours of operation	Position of transmitting antenna coordinates	Elevation of DME transmitting antenna	Remarks
1	2	3	4	5	6	7
NDB	TS	332.5KHz	H24	340741N 1343622E		NDB Unusable : 296° beyond 10NM BLW 5000ft. 315° beyond 30NM BLW 5000ft. 040° -050° within 50NM BLW 10000ft. 240° -250° within 50NM BLW 10000ft.
VOR	TSC	114.9MHz	H24	340747N 1343631E		VOR Unusable: R360 - 010 beyond 33NM BLW 3000ft. R010 - 030 beyond 25NM BLW 2000ft. R030 - 050 beyond 35NM BLW 4000ft. R050 - 060 beyond 30NM BLW 2000ft. R060 - 070 beyond 30NM BLW 4000ft. R080 - 100 beyond 30NM BLW 5000ft. R120 - 130 beyond 30NM BLW 4000ft. R130 - 140 beyond 32NM BLW 2000ft. R140 - 180 beyond 25NM BLW 2000ft. R180 - 200 beyond 33NM BLW 4000ft. R200 - 220 beyond 30NM BLW 6000ft. R220 - 240 beyond 35NM BLW 9000ft. R280 - 290 beyond 20NM BLW 5000ft. R290 - 300 beyond 20NM BLW 4000ft. R300 - 310 beyond 20NM BLW 3000ft. R310 - 330 beyond 20NM BLW 4000ft. R330 - 340 beyond 25NM BLW 4000ft. R340 - 350 beyond 30NM BLW 4000ft. R350 - 360 beyond 33NM BLW 4000ft.
TACAN	TSC	1183MHz (CH-96X)	H24	340748N 1343636E	17ft	TACAN Unusable : R360-010 beyond 34nm BLW 4000ft. R010-020 beyond 29nm BLW 4000ft. R020-030 beyond 38nm BLW 5000ft. R060-070 beyond 36nm BLW 5000ft. R100-110 beyond 38nm BLW 6000ft. R180-190 beyond 37nm BLW 3000ft. R200-210 beyond 28nm BLW 6000ft. R210-220 beyond 35nm BLW 7000ft. R220-240 beyond 24nm BLW 9000ft. R240-250 beyond 33nm BLW 9000ft. R250-270 beyond 35nm BLW 9000ft. R270-280 beyond 35nm BLW 8000ft. R280-290 beyond 28nm BLW 6000ft. R290-300 beyond 30nm BLW 6000ft. R300-310 beyond 15nm BLW 4000ft. R310-340 beyond 15nm BLW 5000ft. R340-350 beyond 31nm BLW 5000ft. R350-360 beyond 22nm BLW 4000ft.
ILS-LOC 29	ITS	108.9MHz	H24	340809N 1343526E		LOC:510m(1673ft) away FM RWY 11 THR, BRG(MAG) 290°
ILS-GP 29	-	329.3MHz	H24	340746.35N 1343704.47E		GP:405.9m(1332ft) inside FM RWY 29 THR, 122m(401ft) S of RCL. HGT of ILS Ref datum 16.5m(54ft). GP Angle 3.0°
ILS-DME 29	ITS	987MHz (CH-26X)	H24	340746.04N 1343704.39E	22ft	DME:405.9m(1332ft) inside FM RWY 29 THR, 132m(433ft) S of RCL.

ILS

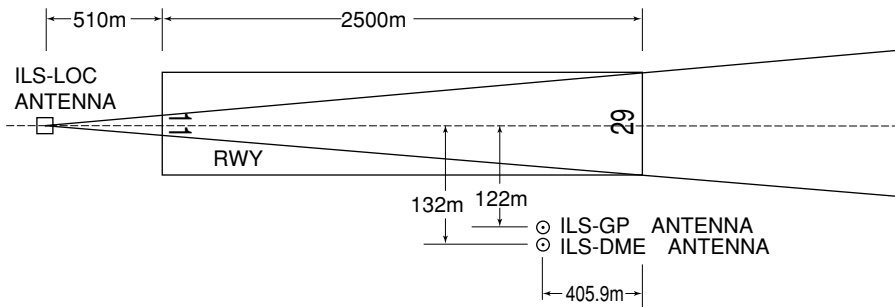

- REMARKS :
- 1. LOC beam BRG(MAG) 290°
  - 2. HGT of ILS REF datum 16.5m(54ft)
  - 3. GP angle 3.0°
  - 4. ELEV of ILS-DME 6.7m(22ft)

**RJOS AD 2.20 LOCAL TRAFFIC REGULATIONS**

1. Airport regulations

PPR Civil transient aircraft must make prior coordination 10days in advance.(088-699-5111)

2. Taxiing to and from stands

Nil

3. Parking area for small aircraft(General aviation)

Nil

4. Parking area for helicopters

Nil

5. Apron - taxiing during winter conditions

Nil

6. Taxiing - limitations

Nil

7. School and training flights - technical test flights - use of runways

Nil

8. Helicopter traffic - limitation

Nil

9. Removal of disabled aircraft from runways

Nil

**RJOS AD 2.21 NOISE ABATEMENT PROCEDURES**

Nil

**RJOS AD 2.22 FLIGHT PROCEDURES**

**1. TAKE OFF MINIMA**

	RWY	REDL & RCLL AVBL		REDL or RCLL AVBL		REDL & RCLL OUT	
		CEIL-RVR	CEIL-VIS	CEIL-RVR	CEIL-VIS	CEIL-RVR	CEIL-VIS
TKOF ALTN AP FILED	11	-	0'400m	-	0'600m	-	0'800m
	29	300'800m	300'800m	300'800m	300'800m	-	300'800m
OTHER	11	AVBL LDG MINIMA					
	29						

NOTE: SIDs are designed in accordance with provisional standards for FLIGHT PROCEDURE DESIGN.

**2. TAKE OFF MINIMA for RNAV DEPARTURE**

	RWY	ACFT CAT	REDL & RCLL		REDL or RCLL or RCL Marking		NIL (DAYTIME ONLY)	
			RVR	VIS	RVR	VIS	RVR	VIS
Multi-Engine ACFT with TKOF ALTN AP FILED	11	A,B,C,D	-	400m	-	400m	-	500m
	29		400m	400m	400m	400m	-	500m
OTHER	11	A,B,C,D	AVBL LDG MINIMA					
	29							

**3. WX MINIMA CONCERNING PAR/ASR APCH PROCEDURE**

PAR RWY 29

ASR RWY 29

MINIMA	THR elev. 37		AD elev. 37	
	CIRCLING		CIRCLING	
CAT	DA(H)	RVR/CMV	MDA(H)	VIS
A	237(200)	1000	580(543)	1600
B			600(563)	2400
C			840(803)	3200
D				

MINIMA	THR elev. 37		AD elev. 37	
	CIRCLING		CIRCLING	
CAT	MDA(H)	RVR/CMV	MDA(H)	VIS
A	500(463)	1500	580(543)	1600
B			600(563)	2400
C		2000	840(803)	3200
D				

**4. Automated Radar Terminal System(ARTS)**

徳島進入管制所の指示のもとに、徳島進入管制区を飛行する航空機は、モードA/3の二次レーダー個別コード及びモードCによる応答を指示される。

モードA/3またはモードC応答用のATCトランスポンダーを搭載していない航空機が当該コードによる応答を指示された場合は、徳島進入管制所に対し、その旨通報すること。

Aircraft flying within the approach control area under the control of Tokushima approach control will be instructed to reply with discrete code on Mode A/3 and Mode C.

If an aircraft non equipped with ATC transponder of Mode A/3 or Mode C instructed to reply such Modes, it shall report a Tokushima approach control accordingly.

**5. Lost communication procedures for arrival aircraft under radar navigational guidance**

If radio communications with Tokushima Radar/Approach/GCA are lost for 1 minute in the pattern or 5 seconds (PAR)/15 seconds (ASR) on final approach, squawk Mode A/3 Code 7600 and ;

- (I)
  1. Contact TOKUSHIMA Tower.
  2. If unable, proceed in accordance with visual flight rules.
  3. If unable, proceed to TOKUSHIMA VORTAC/NDB at last assigned altitude or 3,000 feet whichever is higher, and execute instrument approach.
- (II) Procedures other than above will be issued when situation required.

**RJOS AD 2.23 ADDITIONAL INFORMATION**

Nil

**RJOS AD 2.24 CHARTS RELATED TO AN AERODROME**

Figure-01 Aerodrome/Heliport Chart  
Figure-07 Standard Departure Chart-Instrument (HONMA-RNAV)  
Figure-07 Standard Departure Chart-Instrument (TOSAR, TOKUSHIMA REVERSAL)\*  
Figure-07 Standard Departure Chart-Instrument (MIYAZU)\*  
Figure-07 Standard Departure Chart-Instrument (MISAKI)\*  
Figure-09 Standard Arrival Chart-Instrument\*  
Figure-10 Instrument Approach Chart (ILS Z OR LOC Z RWY29)\*  
Figure-10 Instrument Approach Chart (ILS Y OR LOC Y RWY29)\*  
Figure-10 Instrument Approach Chart (ILS X OR LOC X RWY29)\*  
Figure-10 Instrument Approach Chart (ILS W OR LOC W RWY29)\*  
Figure-10 Instrument Approach Chart (VOR RWY29)\*  
Figure-10 Instrument Approach Chart (NDB RWY29)\*  
Figure-10 Instrument Approach Chart (TACAN A)\*  
Figure-10 Instrument Approach Chart (RNAV(GNSS) RWY29)  
Figure-13 Other Chart (Visual REP)  
Figure-13 Other Chart (LDG CHART)  
Figure-13 Other Chart (MVA CHART)

\*: Designed in accordance with provisional standards for FLIGHT PROCEDURE DESIGN.



**INSTRUMENT APPROACH CHART**

**RJOS / TOKUSHIMA**

**VOR RWY 29**

<b>TOKUSHIMA APP</b> 120.1 - 124.0 261.2 - 284.6	<b>TOKUSHIMA VORTAC</b> 114.9 TSC $\overline{---}$ CH-96X 34°07'47"N / 134°36'31"E	<b>TOKUSHIMA TOWER</b> 118.0 - 126.2 233.8 - 236.8	<b>GCA AVBL</b> CALL TOKUSHIMA APP
--	---	--	--

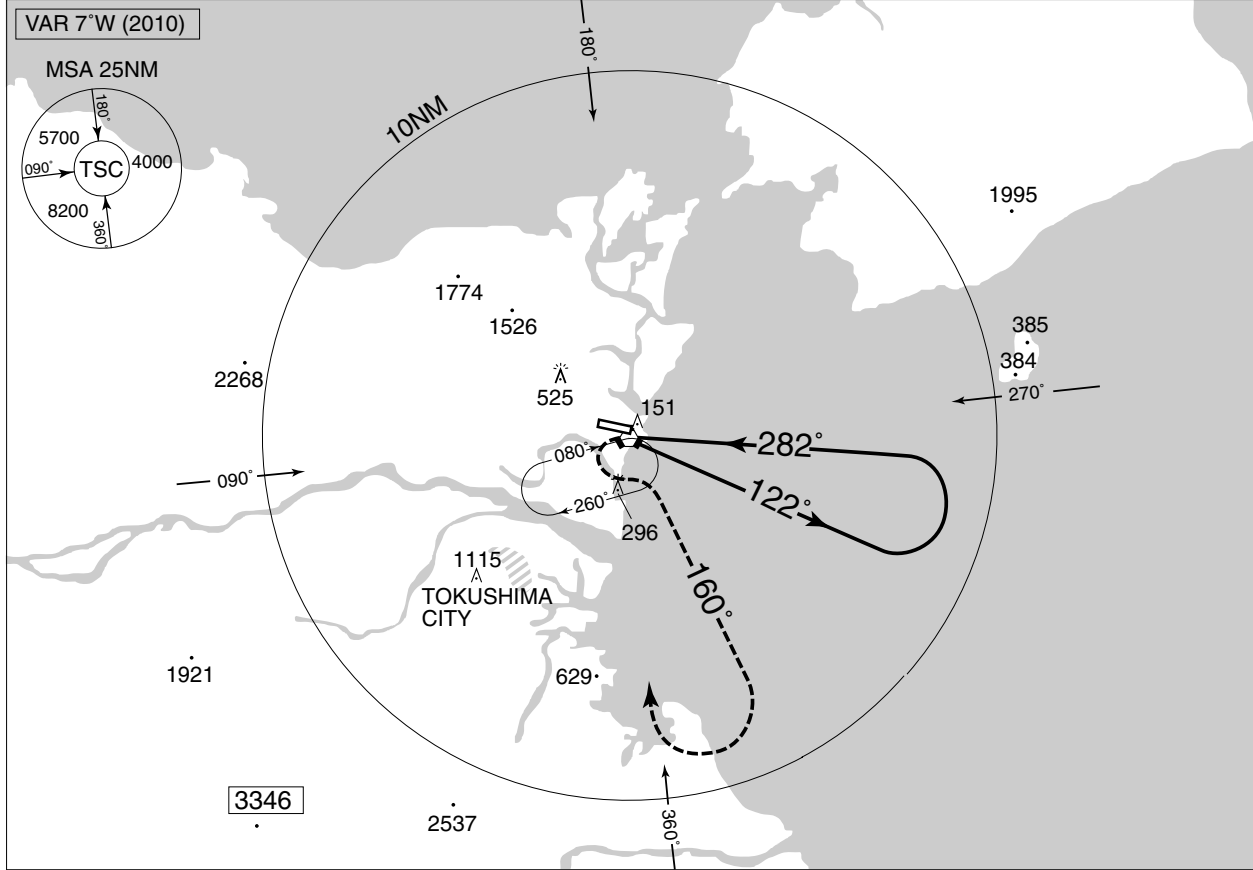

**MISSED APPROACH**

At TSC VORTAC, turn left and climb via TSC R160 to 3000FT, then turn right within 10NM of TSC, proceed to TSC VORTAC and hold.  
 Contact TOKUSHIMA APP.

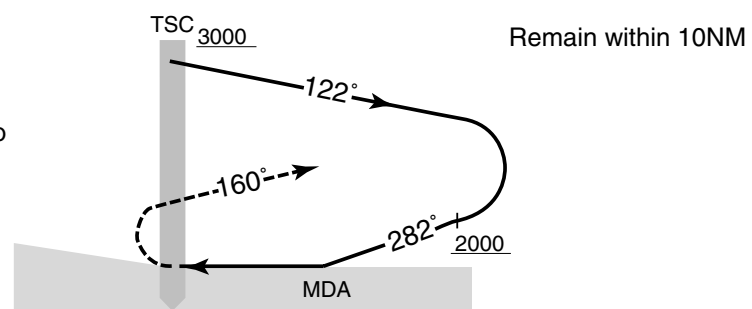

<b>MINIMA</b>		<b>THR elev. 37</b>	<b>AD elev. 37</b>	
<b>CAT</b>			<b>CIRCLING</b>	
	<b>MDA(H)</b>	<b>RVR/CMV</b>	<b>MDA(H)</b>	<b>VIS</b>
A	580 (543)	1500	580 (543)	1600
B			600 (563)	2400
C		2000	840 (803)	3200
D				

INSTRUMENT APPROACH CHART

RJOS / TOKUSHIMA

NDB RWY 29

TOKUSHIMA APP 120.1 - 124.0 261.2 - 284.6	TOKUSHIMA NDB 332.5 TS .. 34°07'41"N / 134°36'22"E	TOKUSHIMA TOWER 118.0 - 126.2 233.8 - 236.8	GCA AVBL CALL TOKUSHIMA APP
---	--	---	-----------------------------------

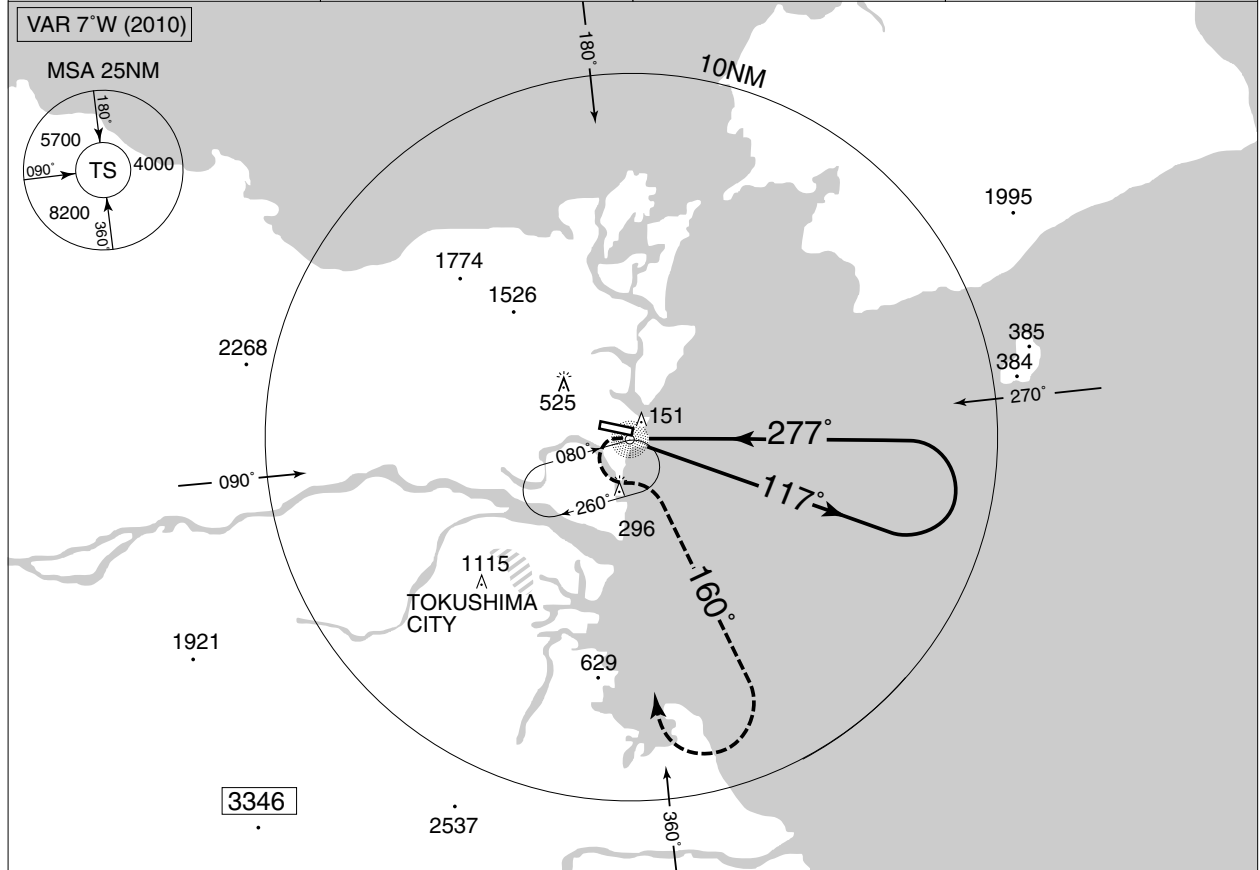

**MISSED APPROACH**  
At TS NDB, turn left and climb via 160° from TS NDB to 3000FT, then turn right within 10NM of TS NDB, proceed to TS NDB and hold.  
Contact TOKUSHIMA APP.

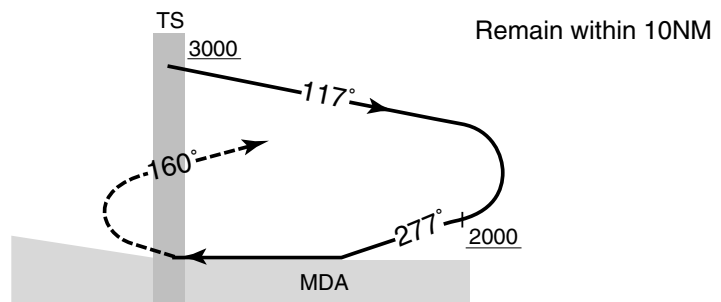

MINIMA	THR elev. 37	AD elev. 37		
CAT			CIRCLING	
	MDA(H)	RVR/CMV	MDA(H)	VIS
A	580 (543)	1500	580 (543)	1600
B			600 (563)	2400
C		2000	840 (803)	3200
D				

INSTRUMENT APPROACH CHART

RJOS / TOKUSHIMA

TACAN A

TOKUSHIMA APP 120.1 - 124.0 261.2 - 284.6	TOKUSHIMA TACAN CH-96X TSC ̄:.. 34°07'48"N / 134°36'36"E	TOKUSHIMA TOWER 118.0 - 126.2 233.8 - 236.8	GCA AVBL CALL TOKUSHIMA APP
---	--	---	-----------------------------------

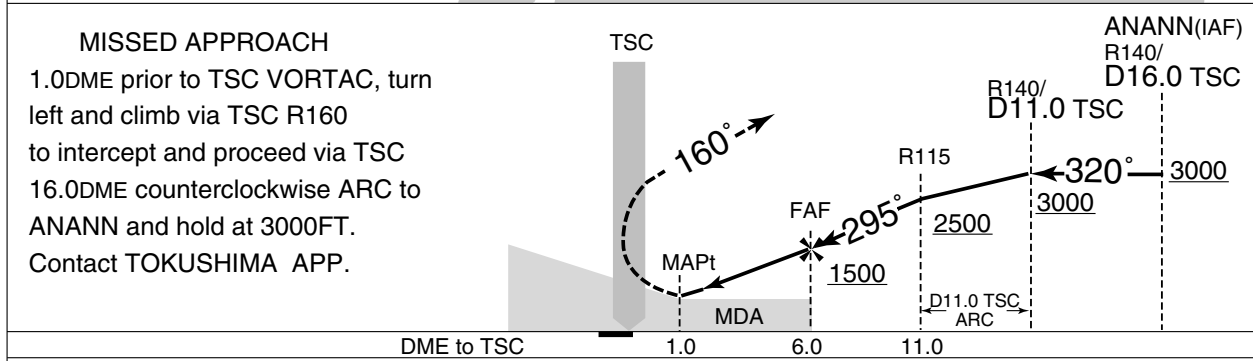
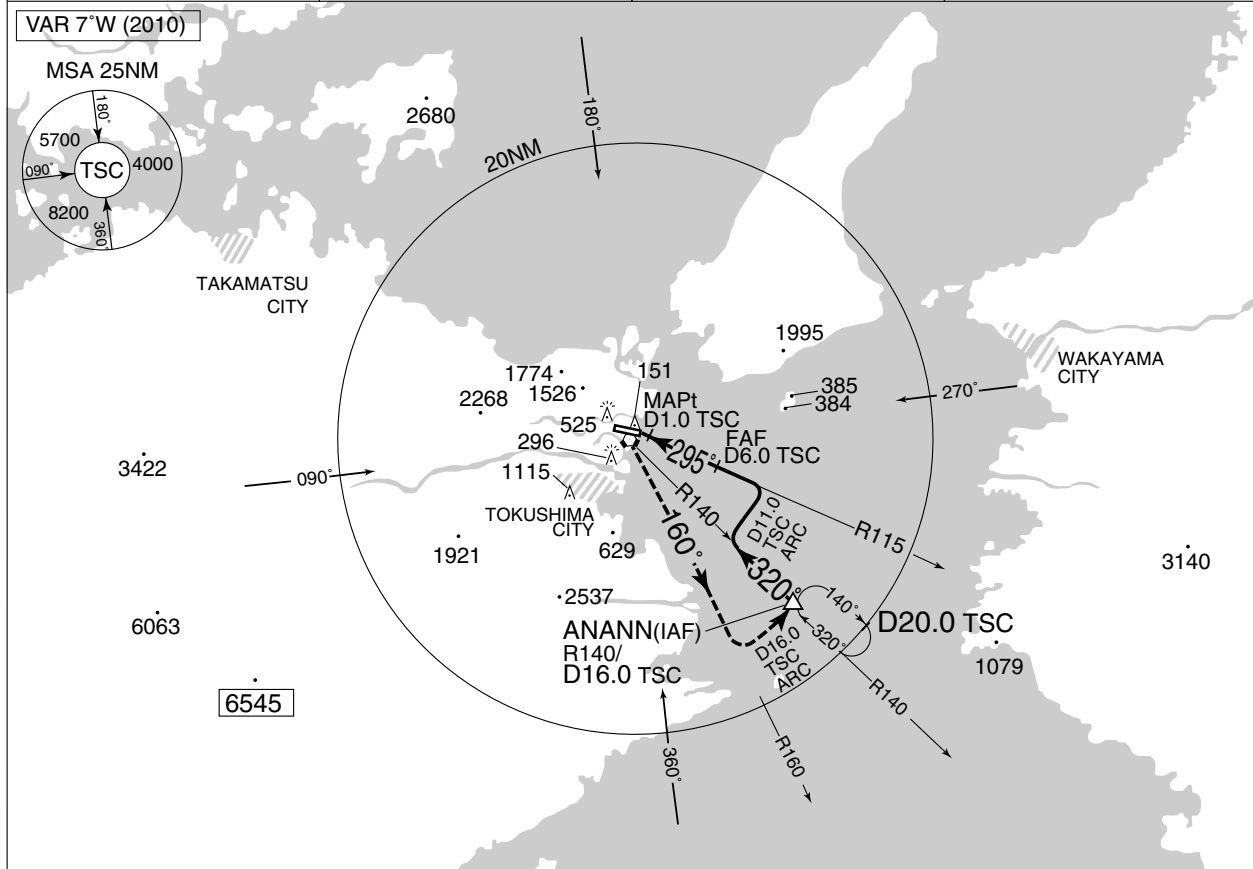

MINIMA		THR elev. 37	AD elev. 37
CAT	CIRCLING		
	MDA(H)	VIS	
A	580 (543)	1600	
B			
C	600 (563)	2400	
D	840 (803)	3200	



RJOS / TOKUSHIMA

Visual REP

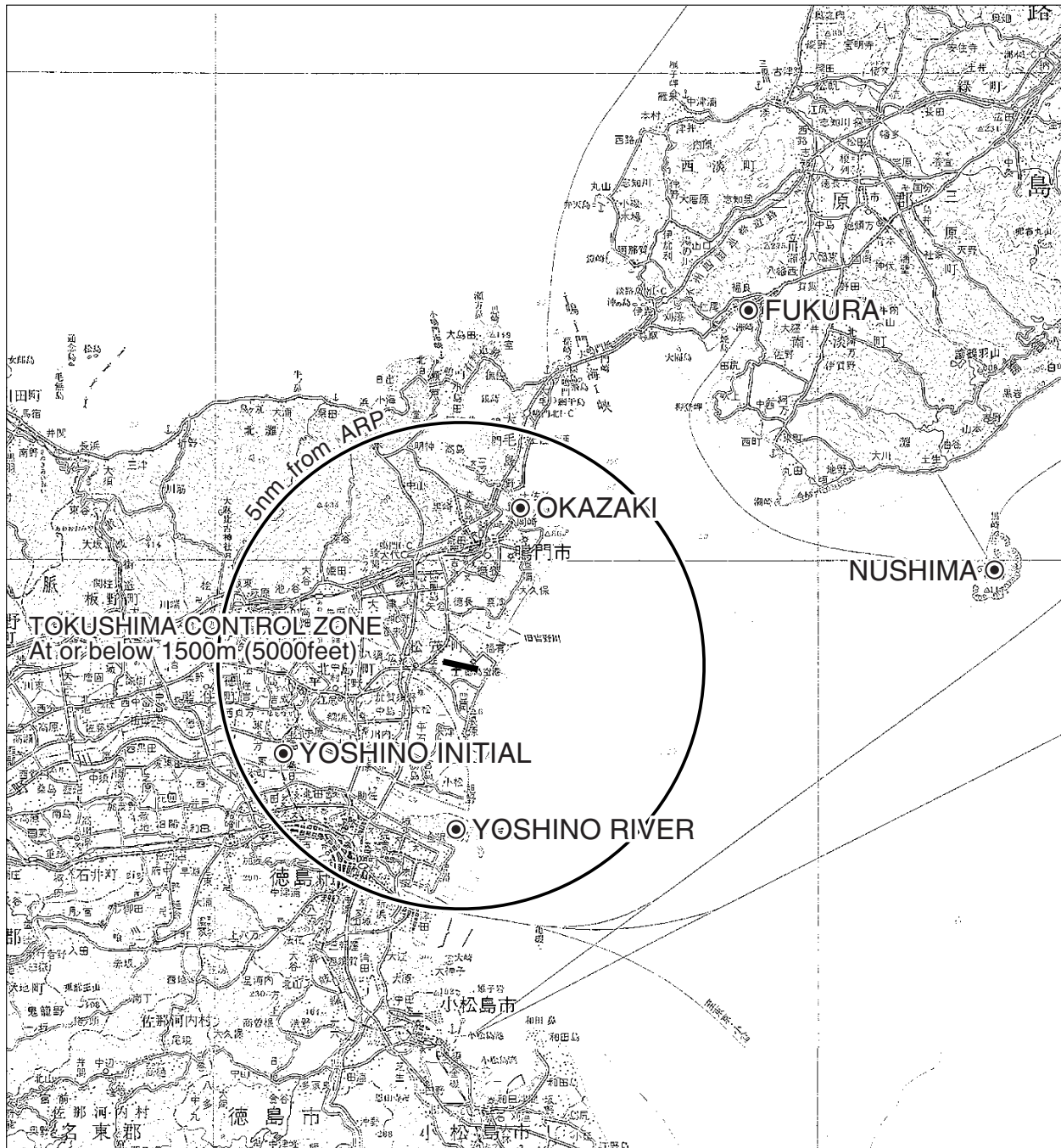

Call sign	BRG / DIST from ARP	Remarks
沼島 Nushima	086°/11.0NM	灯台 Lighthouse
福良 Fukura	042°/8.5NM	港 Harbor
吉野イニシャル Yoshino Initial	254°/4.5NM	鉄道橋中央 the center of iron bridge
岡崎 Okazaki	036°/3.3NM	灯台 Lighthouse
吉野リバー Yoshino River	195°/3.3NM	吉野川河口 River-mouth

RJOS / TOKUSHIMA

LDG CHART

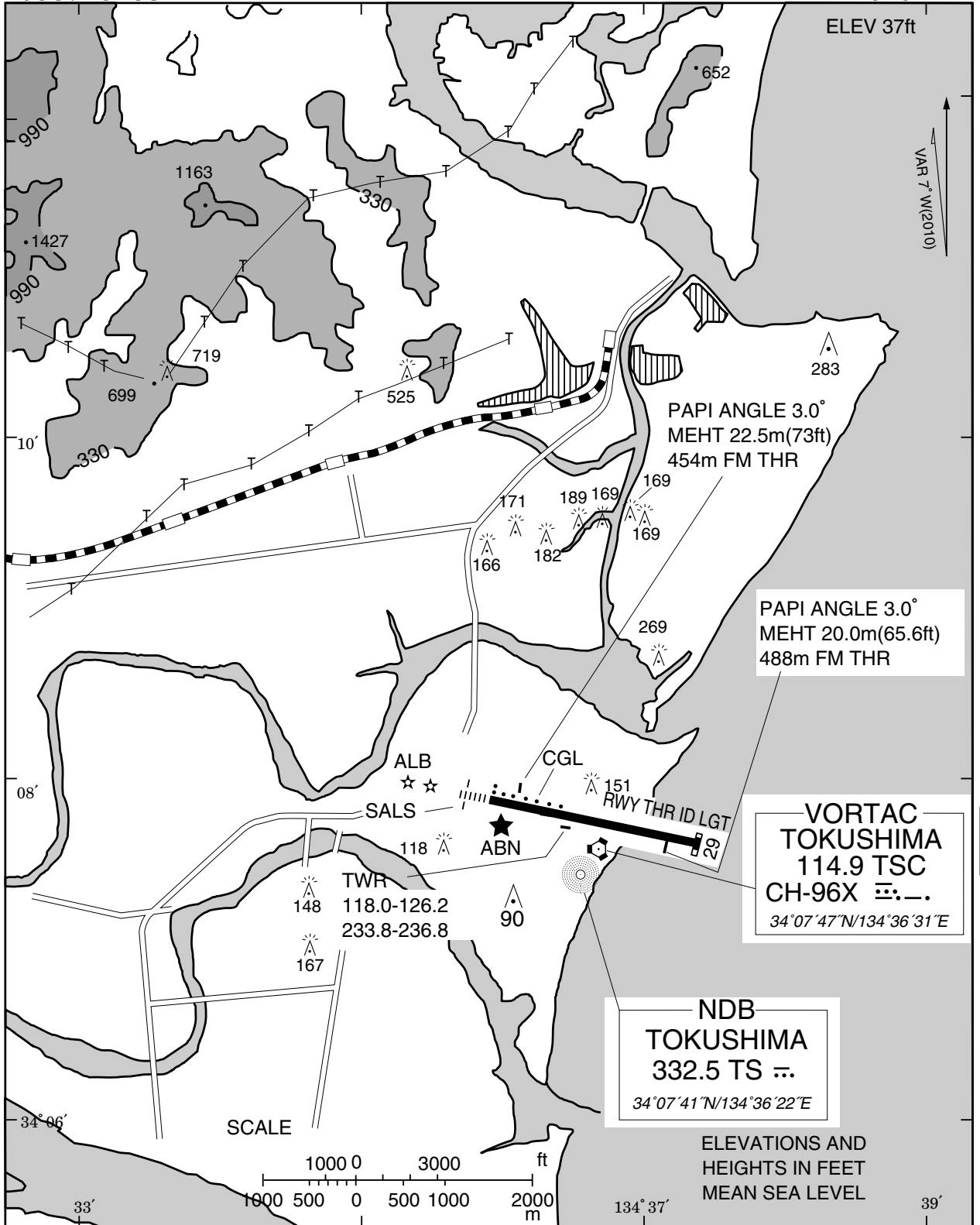

STANDARD DEPARTURE CHART-INSTRUMENT

RJOS / TOKUSHIMA

RNAV SID and TRANSITION

HONMA ONE DEPARTURE / KILAP TRANSITION		RNAV1
Note 1) DME/DME/IRU or GNSS required. ※The aircraft equipped with only DME/DME/IRU must be able to update its position without delay at the starting point of take-off rolling. 2) RADAR service required.	Critical DME	RWY29 AJD : 3.0NM to HATIS – HATIS KILAP TRANSITION AJD : 4.0NM to KMANO – KMANO
	DME GAP	–
	Inappropriate Nav aids	See AD1.1.6.10.3. Inappropriate NAVAIDs for RNAV1

VAR 8°W (2018)

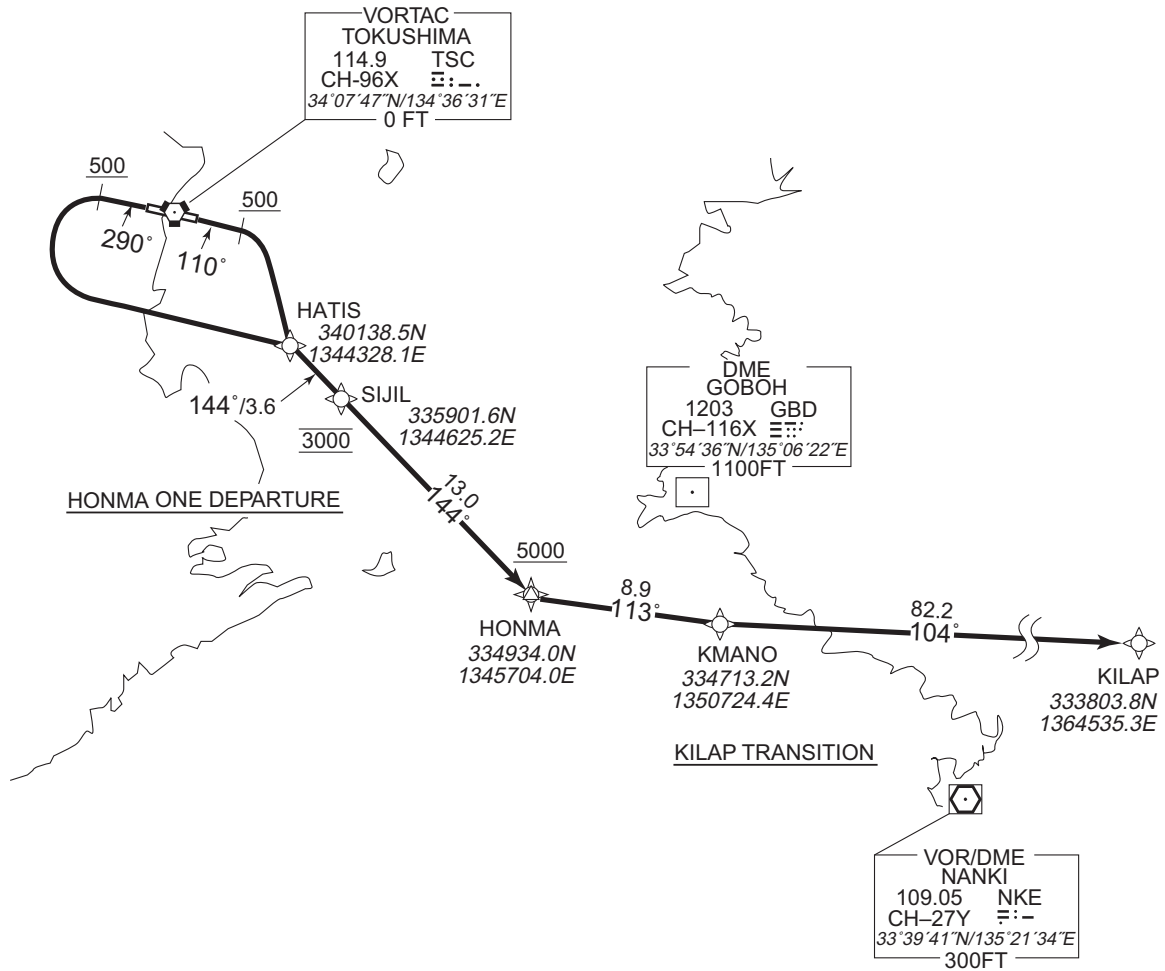

HONMA ONE DEPARTURE

RWY11 : Climb on HDG110° at or above 500FT, turn right direct to HATIS, to SIJIL at 3000FT, to HONMA at or above 5000FT.  
 RWY29 : Climb on HDG290° at or above 500FT, turn left direct to HATIS, to SIJIL at 3000FT, to HONMA at or above 5000FT.

Note RWY29 : 5.0% climb gradient required up to 1200FT.  
 OBST ALT 1115FT located at 4.9NM FM end of RWY29.

KILAP TRANSITION

From HONMA at or above 5000FT, to KMANO, to KILAP.

CHANGE : New PROC ( KILAP TRANSITION ), Abolition PROC ( MEIWA TRANSITION ), VAR

STANDARD DEPARTURE CHART-INSTRUMENT

RJOS / TOKUSHIMA

RNAV SID and TRANSITION

HONMA ONE DEPARTURE

RWY11

Serial Number	Path Descriptor	Waypoint Identifier	Fly Over	Course °M(°T)	Magnetic Variation	Distance (NM)	Turn Direction	Altitude (FT)	Speed (KIAS)	Vertical Angle	Navigation Specification
001	VA	-	-	110 (102.6)	-7.6	-	-	+500	-	-	RNAV1
002	DF	HATIS	-	-	-7.6	-	R	-	-	-	RNAV1
003	TF	SIJIL	-	144 (136.9)	-7.6	3.6	-	3000	-	-	RNAV1
004	TF	HONMA	-	144 (136.9)	-7.6	13.0	-	+5000	-	-	RNAV1

RWY29

Serial Number	Path Descriptor	Waypoint Identifier	Fly Over	Course °M(°T)	Magnetic Variation	Distance (NM)	Turn Direction	Altitude (FT)	Speed (KIAS)	Vertical Angle	Navigation Specification
001	VA	-	-	290 (282.6)	-7.6	-	-	+500	-	-	RNAV1
002	DF	HATIS	-	-	-7.6	-	L	-	-	-	RNAV1
003	TF	SIJIL	-	144 (136.9)	-7.6	3.6	-	3000	-	-	RNAV1
004	TF	HONMA	-	144 (136.9)	-7.6	13.0	-	+5000	-	-	RNAV1

KILAP TRANSITION

Serial Number	Path Descriptor	Waypoint Identifier	Fly Over	Course °M(°T)	Magnetic Variation	Distance (NM)	Turn Direction	Altitude (FT)	Speed (KIAS)	Vertical Angle	Navigation Specification
001	IF	HONMA	-	-	-7.6	-	-	+5000	-	-	RNAV1
002	TF	KMANO	-	113 (105.2)	-7.6	8.9	-	-	-	-	RNAV1
003	TF	KILAP	-	104 (095.9)	-7.6	82.2	-	-	-	-	RNAV1

CHANGE : New PROC ( KILAP TRANSITION ), Abolition PROC ( MEIWA TRANSITION ), VAR

STANDARD DEPARTURE CHART -INSTRUMENT

RJOS / TOKUSHIMA

➡ SID and TRANSITION

MISAKI ONE DEPARTURE

RWY29 : Turn left within 3NM,...

RWY11 : Turn right,...

...climb via TSC R143 (143° from TS NDB) to HONMA.

Cross TSC 12.0DME (12NM of TS NDB) at 3000FT, cross HONMA at or above 8000FT.

Note1 : When take off RWY29, following climb gradient should be maintained until passing 300FT

Speed (Knots)	60	90	120	150	180	210
Rate (Feet/Min)	300	450	600	750	900	1050

Note2 : TV antenna tower (Mt. BIZAN : height 1115FT) at TSC R230 5DME. (5NM on 230° from TS NDB).

KUSHIMOTO TRANSITION

From over HONMA, via KEC R305 to KEC VORTAC.

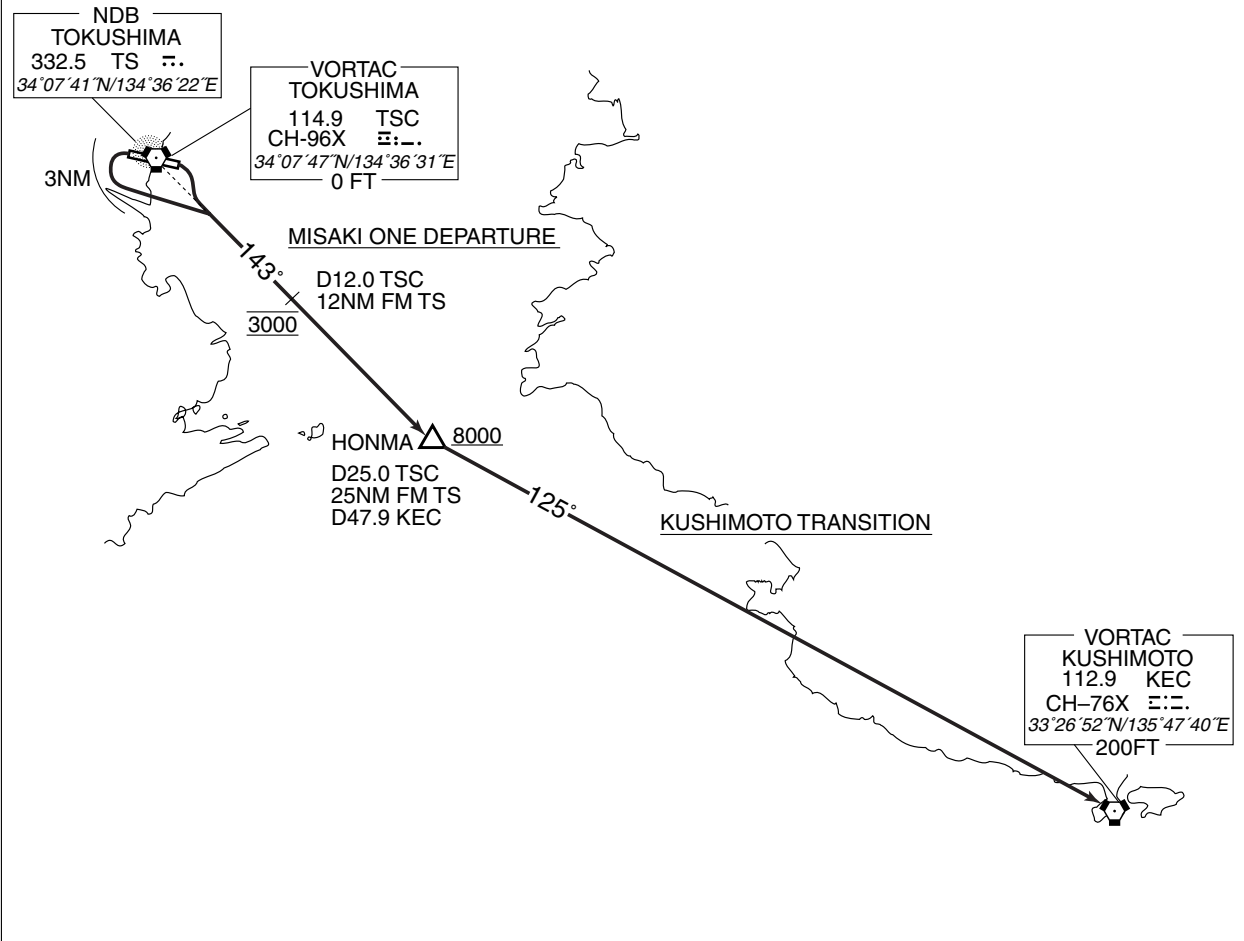

RJOS / TOKUSHIMA

Minimum Vectoring Altitude CHART

VAR 7°W (2013)

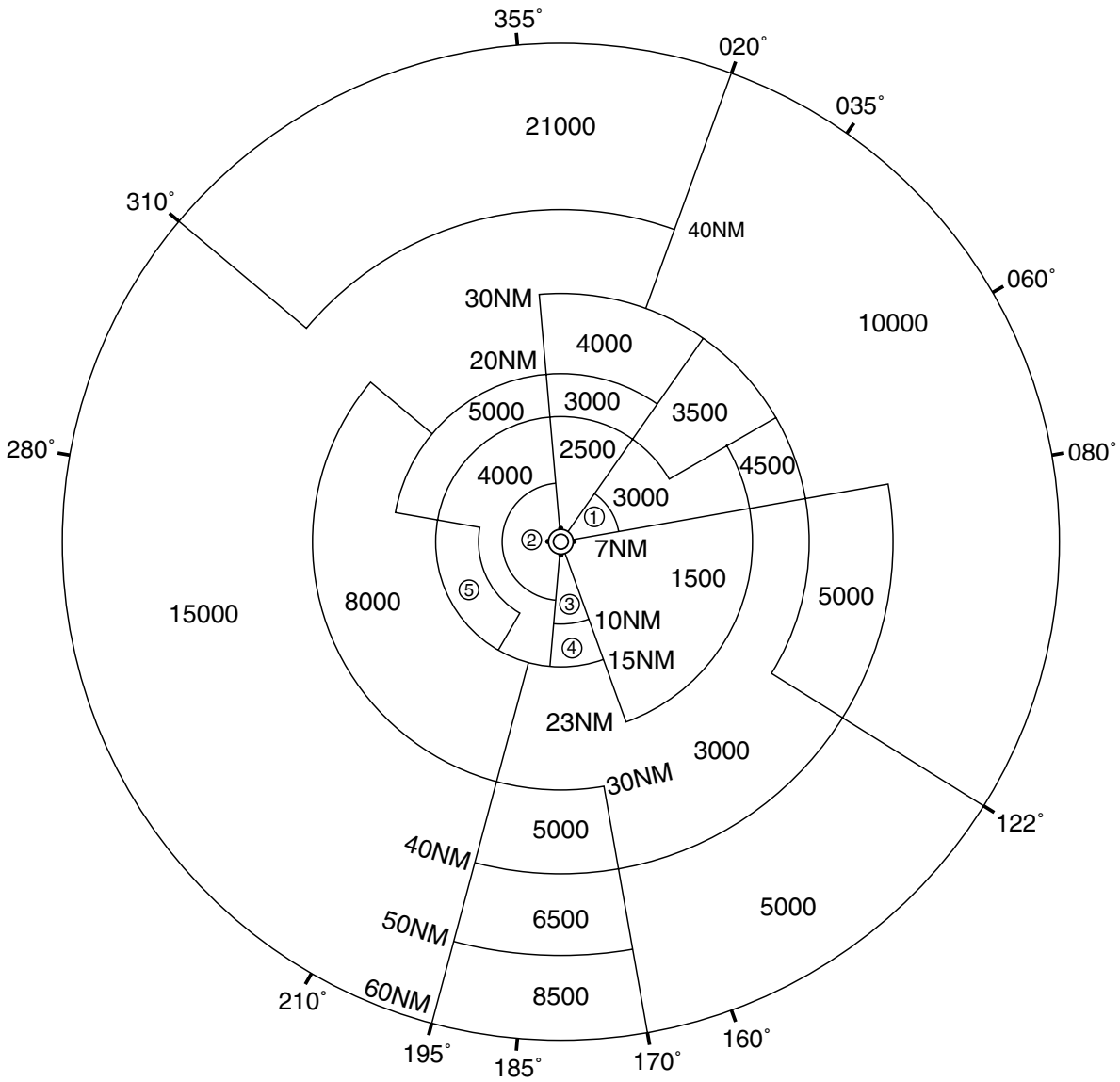

- ① 2000
- ② 3000
- ③ 1700
- ④ 2100
- ⑤ 4500

CENTER : 340751N/1343552E (RADAR SITE)

STANDARD DEPARTURE CHART-INSTRUMENT

RJOS / TOKUSHIMA

SID

TOSAR FOUR DEPARTURE

RWY 29 : Turn left within 3NM....

RWY 11 : Turn right....

....climb via TSC R160 (160° from TS NDB) to TSC 13.0DME (13NM of TS NDB), turn right to intercept and proceed via TSC R187 (187° from TS NDB) to TOSAR.

Cross TSC 13.0DME (13NM of TS NDB) at 3000FT, cross TSC 20.0DME (20NM of TS NDB) at 6000FT, cross TOSAR at assigned altitude.

\* See Note.

TOKUSHIMA REVERSAL FIVE DEPARTURE

RWY 29 : Turn left within 3NM....

RWY 11 : Turn right....

.... climb via TSC R160 (160° from TS NDB) to TSC 13.0DME (13NM of TS NDB), then turn right proceed to TSC VORTAC (TS NDB).

Cross TSC 13.0DME (13NM of TS NDB) at 3000FT, cross TSC VORTAC (TS NDB) at or above 6000FT.

\* See Note.

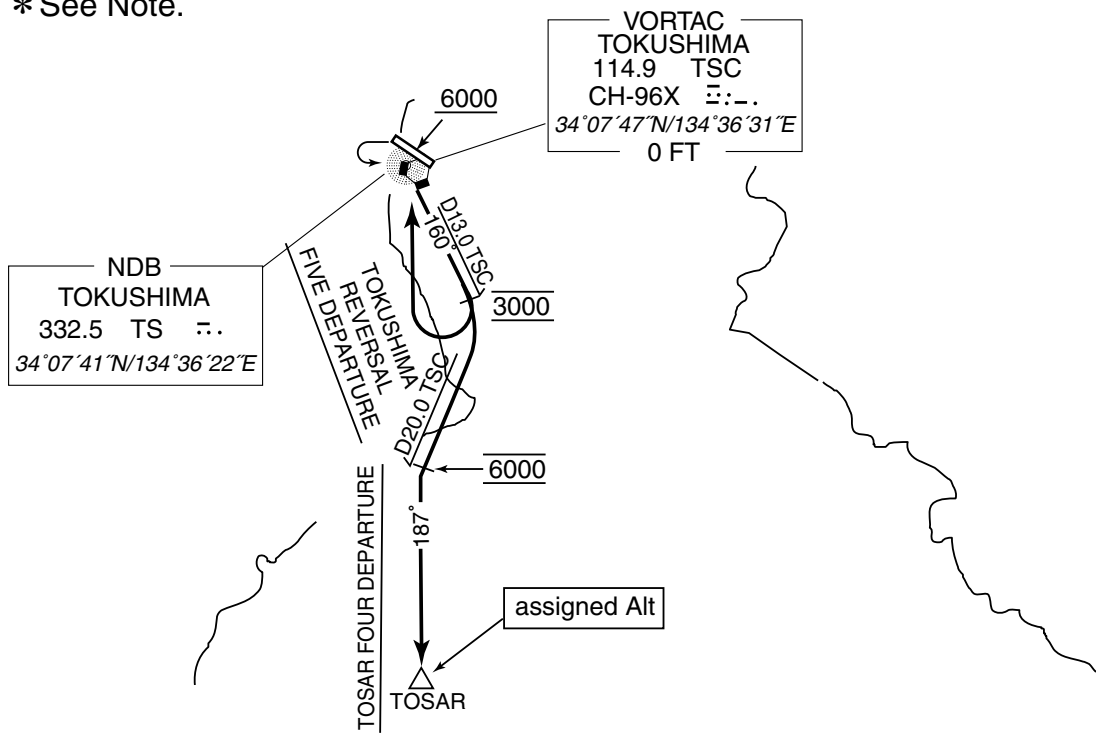

STANDARD DEPARTURE CHART-INSTRUMENT

RJOS / TOKUSHIMA

SID

MIYAZU EIGHT DEPARTURE

RWY 29 : Turn left within 3NM....

RWY 11 : Turn right....

....cross TS NDB at or above 1000FT, climb via 026° from TS NDB until intercepting ITE R297, climb via ITE 22.2DME clockwise ARC to intercept and proceed via YME R170 to YME VOR/DME.

Cross ITE R297 at or above 7000FT.

\* See Note.

Note1 : When take off RWY29, following climb gradient should be maintained until passing 300FT.

Speed (Knots)	60	90	120	150	180	210
Rate (Feet/Min)	300	450	600	750	900	1050

2 : TV antenna tower (Mt. BIZAN: height 1115FT) at TSC R230 5DME. (5NM on 230° from TS NDB).

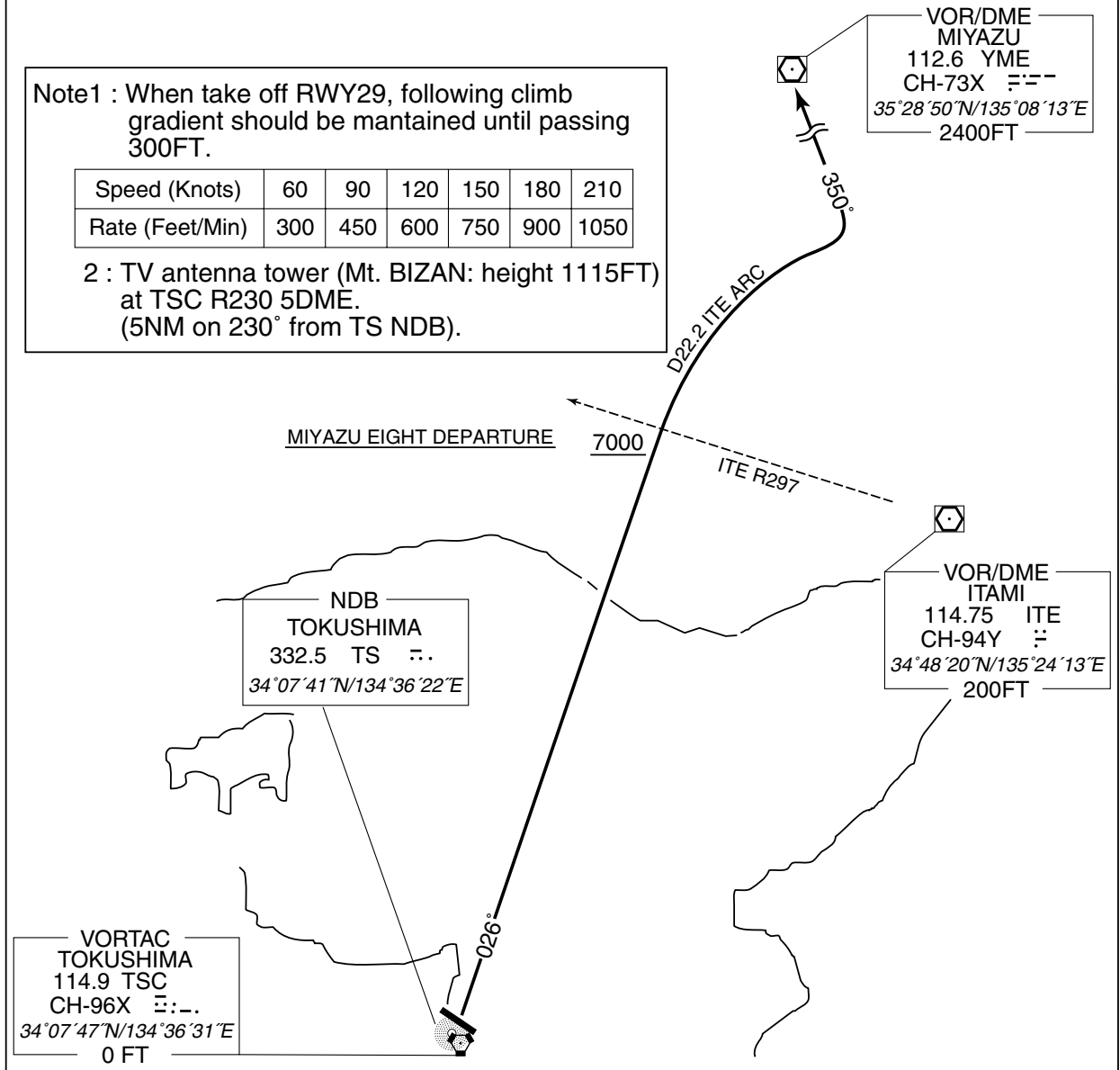



INSTRUMENT APPROACH CHART

RJOS / TOKUSHIMA

RNAV(GNSS) RWY29

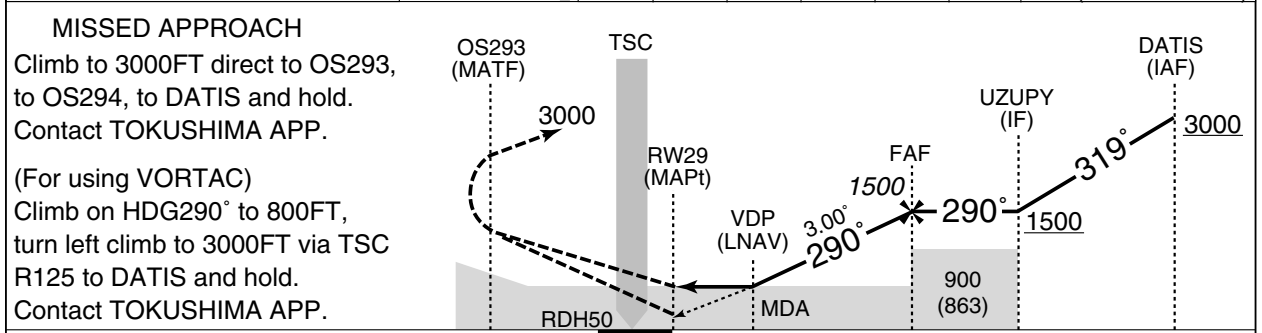
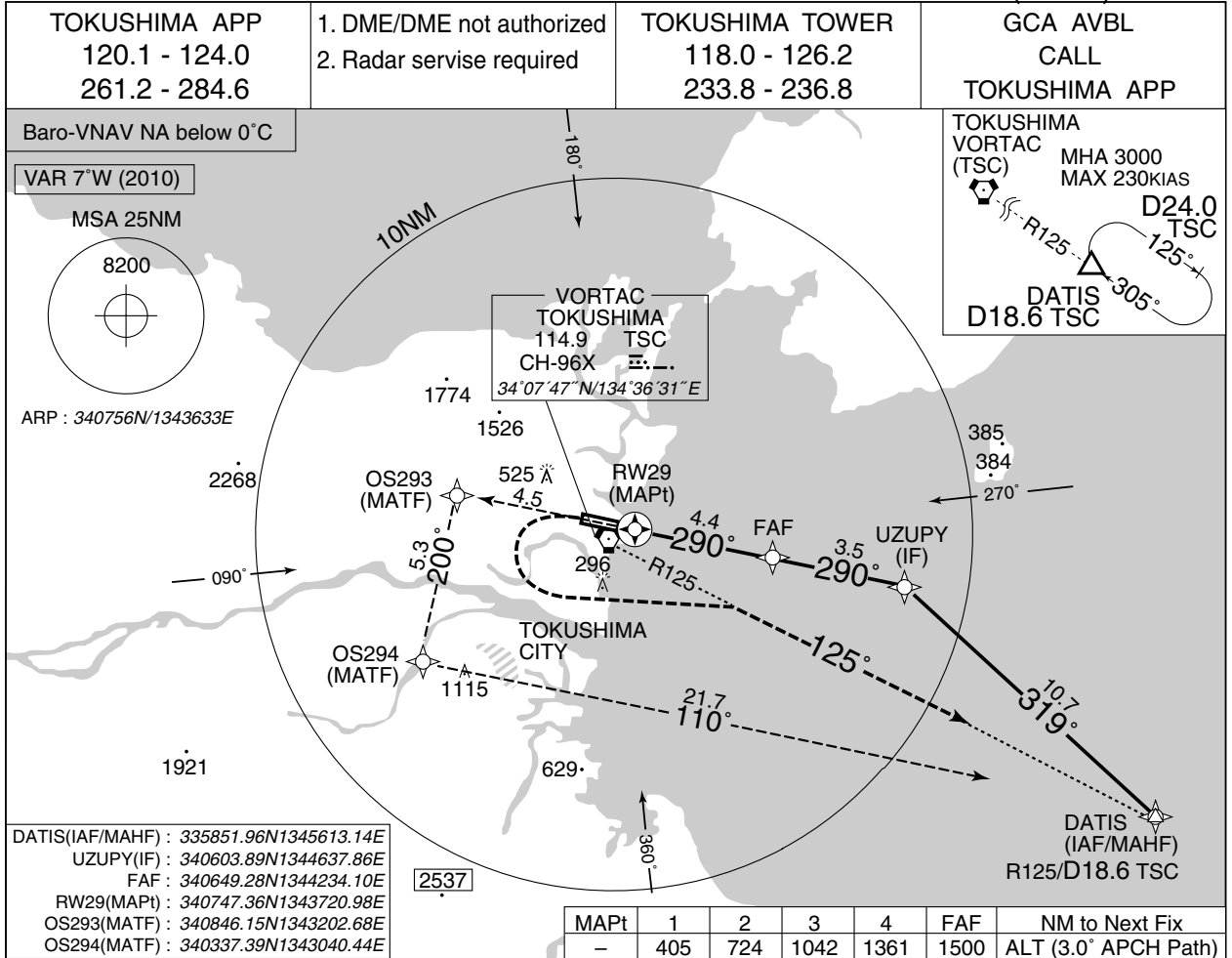

Missed APCH climb gradient MNM 5.0%

MINIMA		THR elev. 37		AD elev. 37			
CAT	LNAV/VNAV		LNAV		CIRCLING		
	DA(H)	RVR/CMV	MDA(H)	RVR/CMV	MDA(H)	VIS	
A	380 (343)	1500	380 (343)	1500	580 (543)	1600	
B					600 (563)		
C					1800		2400
D					2000		840 (803)

MINIMA with Missed APCH climb gradient of 2.5% are not established.

STANDARD ARRIVAL CHART-INSTRUMENT

RJOS / TOKUSHIMA

STAR

**STAR**

TOSAR ARRIVAL

From over TOSAR, proceed via TSC R-187 to TSC VORTAC (007DEG to TS NDB).

Cross TSC VORTAC (TS NDB) at 5,000 feet.

STAR

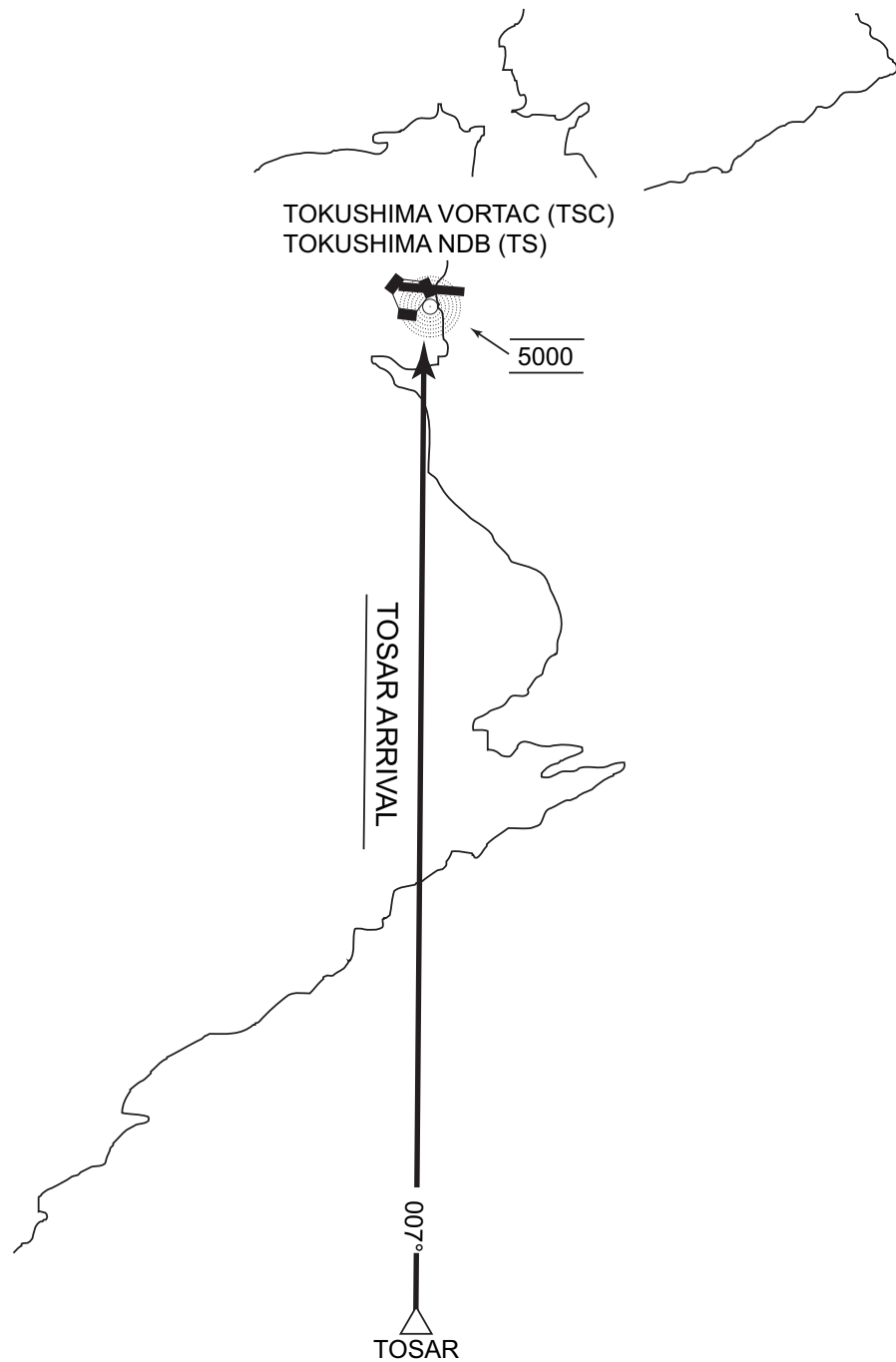

INSTRUMENT APPROACH CHART

RJOS / TOKUSHIMA

ILS Z or LOC Z RWY 29

TOKUSHIMA APP 120.1 - 124.0 261.2 - 284.6	ILS-LOC 108.9 ITS #. ILS-GP 329.3 ILS-DME CH-26X	TOKUSHIMA TOWER 118.0 - 126.2 233.8 - 236.8	GCA AVBL CALL TOKUSHIMA APP
---	---	---	-----------------------------------

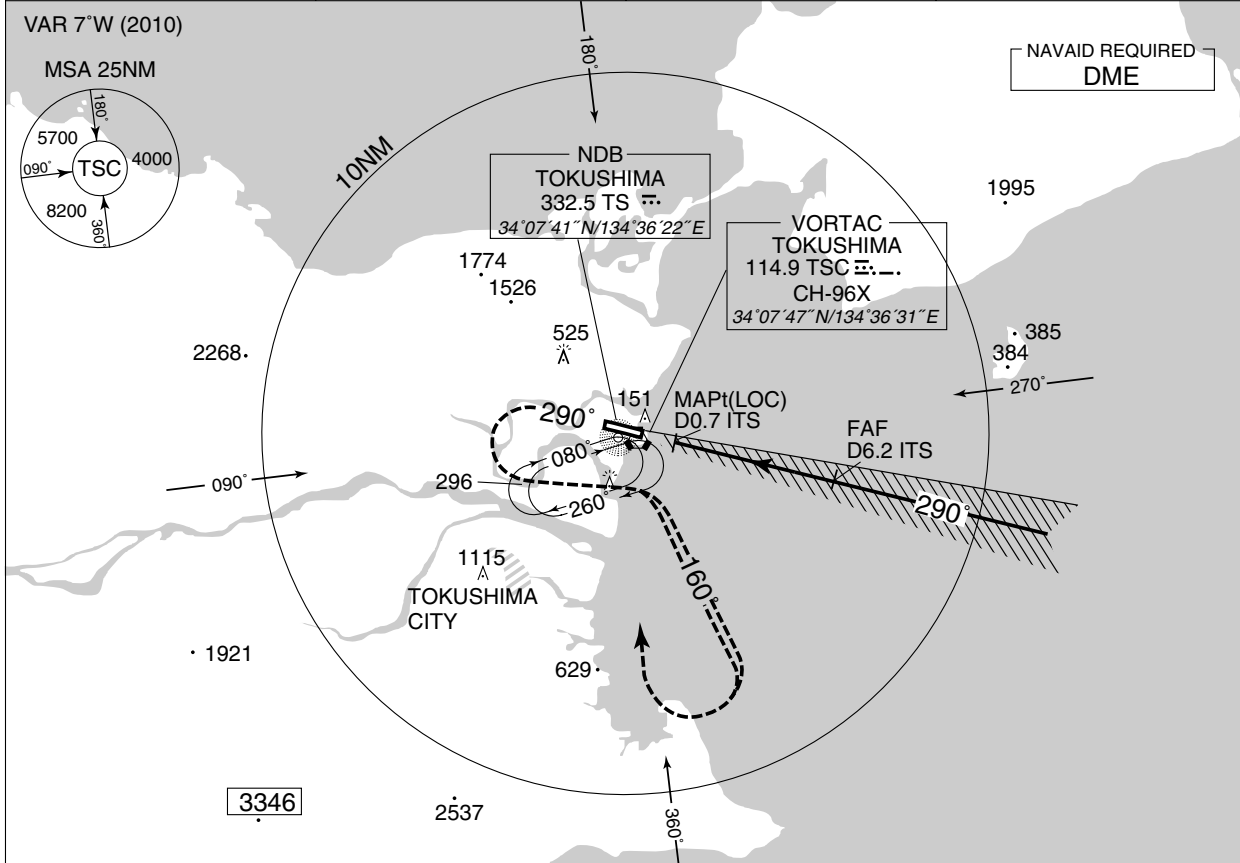

MISSED APPROACH

Climb on 290° to 800FT or above within ITS 3.8DME(TSC3.4DME), turn left and climb via TSC R160(on160° from TS NDB) to 3000FT, then turn right within TSC 10DME(10nm of TS NDB), proceed to TSC VORTAC(TS NDB) and hold.  
Contact TOKUSHIMA APP.

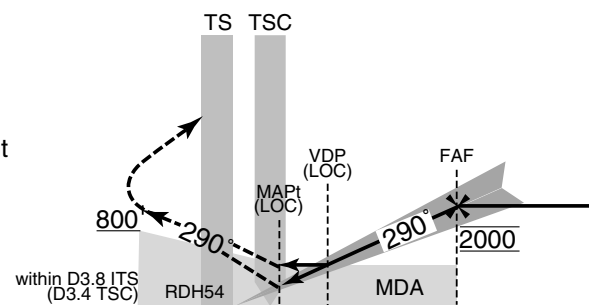

DME to ITS	0.7	1.1	6.2
NM to THR	0.5	0.9	6.0

MINIMA		THR elev. 37		AD elev. 37				
CAT	CAT I		LOC		CIRCLING			
	DA(H)	RVR/CMV	MDA(H)	RVR/CMV	MDA(H)	VIS		
A	237 (200)	1000	340 (303)	1500	580 (543)	1600		
B								
C				1800			600 (563)	2400
D				2000			840 (803)	3200

INSTRUMENT APPROACH CAHRT

RJOS / TOKUSHIMA

ILS Y or LOC Y RWY 29

TOKUSHIMA APP 120.1 - 124.0 261.2 - 284.6	ILS-LOC 108.9 ITS 3. ILS-GP 329.3 ILS-DME CH-26X	TOKUSHIMA TOWER 118.0 - 126.2 233.8 - 236.8	GCA AVBL CALL TOKUSHIMA APP
---	---	---	-----------------------------------

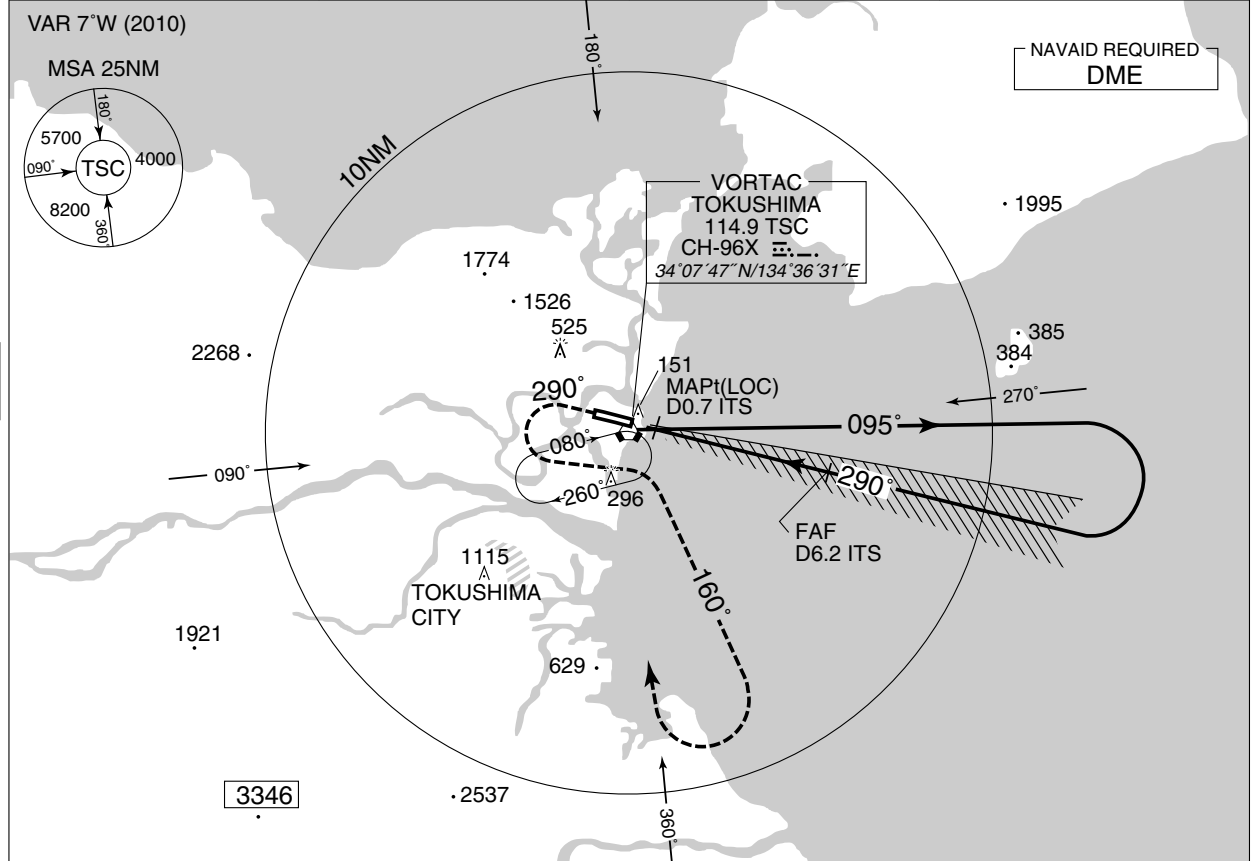

**MISSED APPROACH** Remain within 14nm

Climb on 290° to 800FT or above within ITS 3.8DME (TSC 3.4DME), turn left and climb via TSC R160 to 3000FT, then turn right within TSC 10DME, proceed to TSC VORTAC and hold. Contact TOKUSHIMA APP.

	DME to ITS	0.7	1.1	6.2
	NM to THR	0.5	0.9	6.0

MINIMA		THR elev. 37		AD elev. 37		
CAT	CAT I		LOC		CIRCLING	
	DA(H)	RVR/CMV	MDA(H)	RVR/CMV	MDA(H)	VIS
A	237 (200)	1000	340 (303)	1500	580 (543)	1600
B				1800		
C				2000		
D				2000		

INSTRUMENT APPROACH CHART

RJOS / TOKUSHIMA

ILS X or LOC X RWY 29

TOKUSHIMA APP 120.1 - 124.0 261.2 - 284.6	ILS-LOC 108.9 ITS 329.3 ILS-GP 329.3 ILS-DME CH-26X	TOKUSHIMA TOWER 118.0 - 126.2 233.8 - 236.8	GCA AVBL CALL TOKUSHIMA APP
---	--	---	-----------------------------------

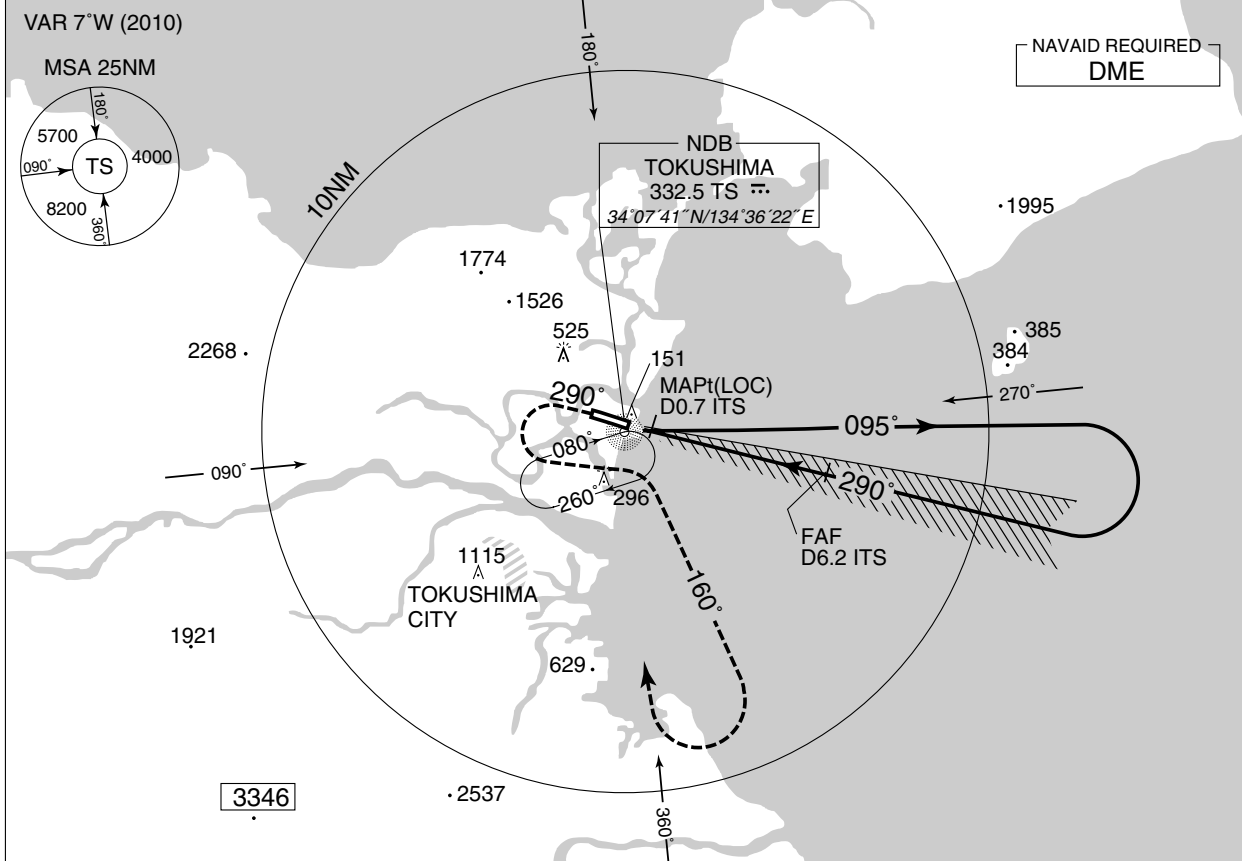

MISSED APPROACH

Climb on 290° to 800FT or above within ITS 3.8DME, turn left and climb via 160° from TS NDB to 3000FT, then turn right within 10nm of TS NDB, proceed to TS NDB and hold.  
Contact TOKUSHIMA APP.

Remain within 14nm

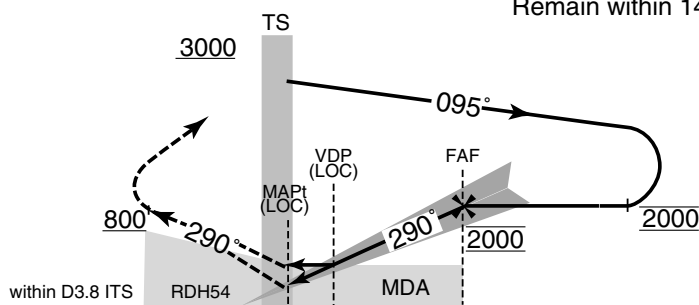

DME to ITS	0.7	1.1	6.2
NM to THR	0.5	0.9	6.0

MINIMA		THR elev. 37		AD elev. 37		
CAT	CAT I		LOC		CIRCLING	
	DA(H)	RVR/CMV	MDA(H)	RVR/CMV	MDA(H)	VIS
A	237 (200)	1000	340 (303)	1500	580 (543)	1600
B				1800		
C				2000		
D				2000		

INSTRUMENT APPROACH CHART

RJOS / TOKUSHIMA

ILS W or LOC W RWY 29

TOKUSHIMA APP 120.1 - 124.0 261.2 - 284.6	ILS-LOC 108.9 ITS #. ILS-GP 329.3 ILS-DME CH-26X	TOKUSHIMA TOWER 118.0 - 126.2 233.8 - 236.8	GCA AVBL CALL TOKUSHIMA APP
---	---	---	-----------------------------------

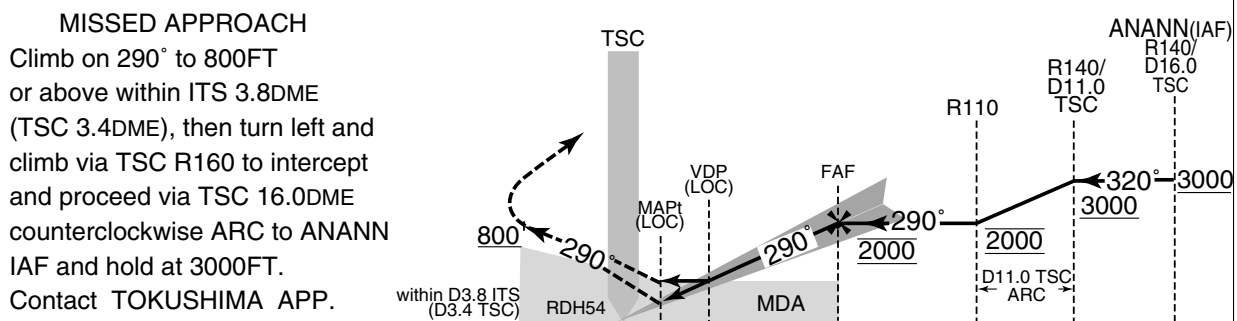
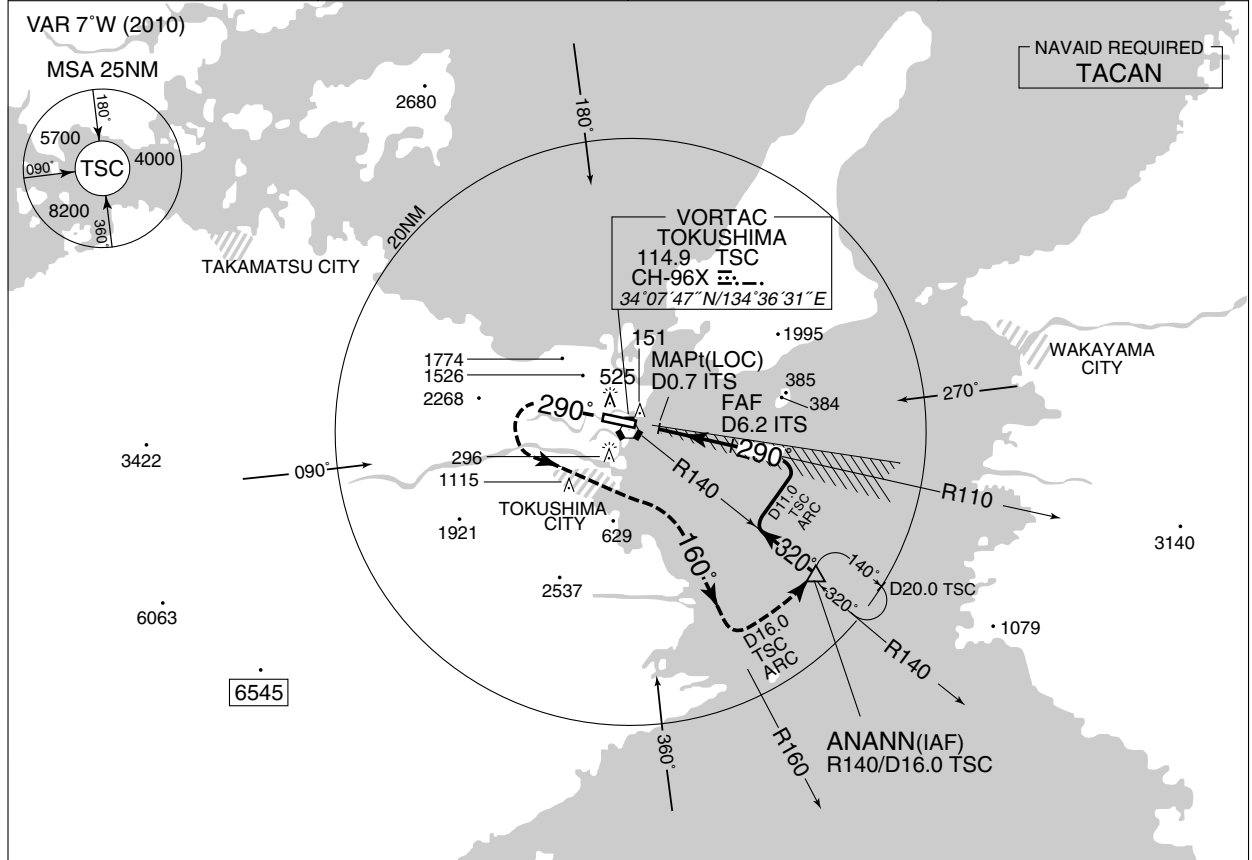

MISSED APPROACH	Climb on 290° to 800FT or above within ITS 3.8DME (TSC 3.4DME), then turn left and climb via TSC R160 to intercept and proceed via TSC 16.0DME counterclockwise ARC to ANANN IAF and hold at 3000FT. Contact TOKUSHIMA APP.
DME to ITS	0.7 1.1 6.2 11.0
NM to THR	0.5 0.9 6.0 10.8

MINIMA		THR elev. 37		AD elev. 37		
CAT	CAT I		LOC		CIRCLING	
	DA(H)	RVR/CMV	MDA(H)	RVR/CMV	MDA(H)	VIS
A	237 (200)	1000	340 (303)	1500	580 (543)	1600
B						
C				1800	600 (563)	
D				2000	840 (803)	

徳島進入管制区  
Tokushima Approach Control Area

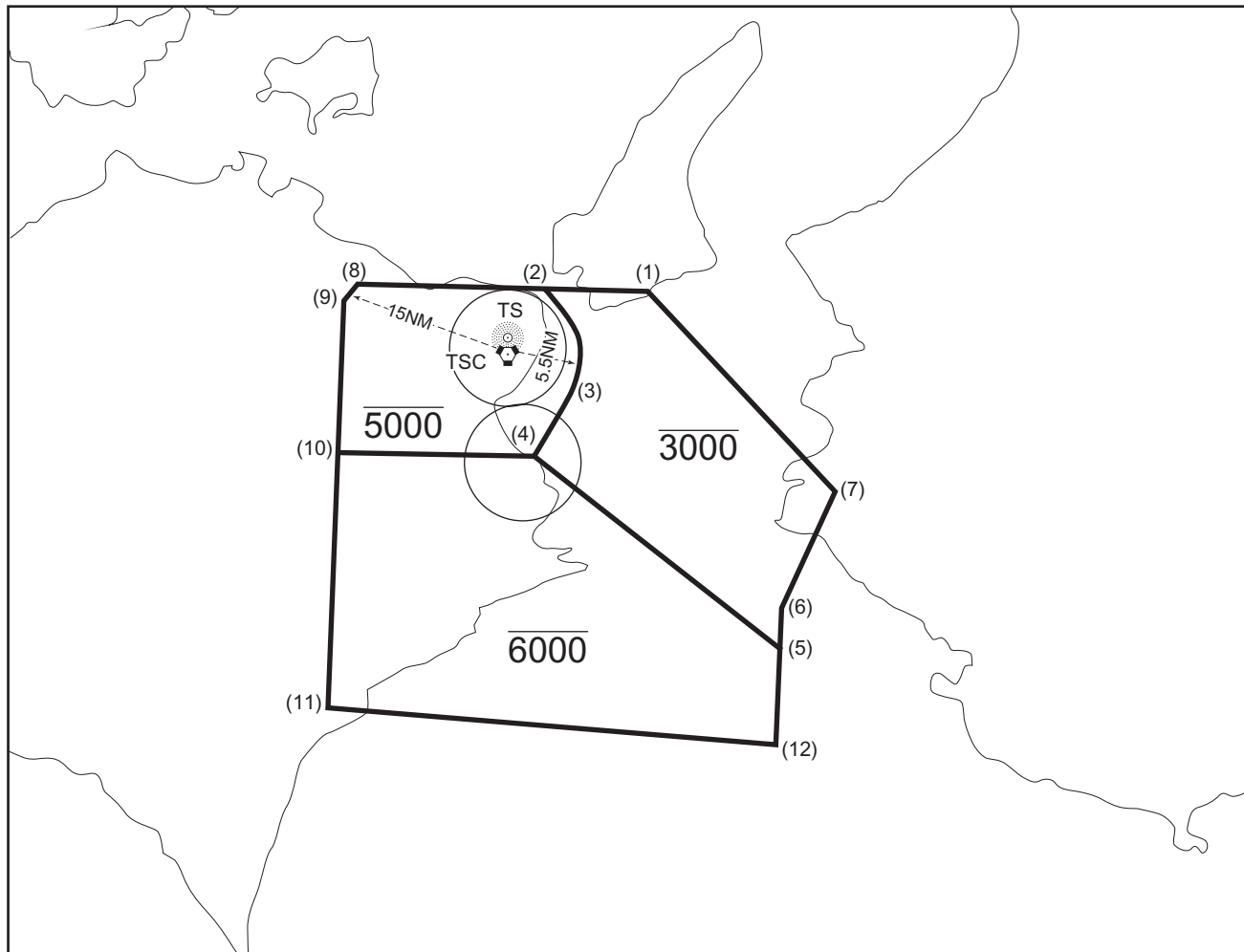

Point list

- |                      |                       |
|----------------------|-----------------------|
| (1) 341300N/1345028E | (7) 335551N/1350941E  |
| (2) 341300N/1343838E | (8) 341300N/1341932E  |
| (3) 340527N/1344232E | (9) 341136N/1341900E  |
| (4) 335837N/1343856E | (10) 335801N/1341900E |
| (5) 334323N/1350500E | (11) 333545N/1341900E |
| (6) 334636N/1350500E | (12) 333338N/1350500E |

# ILS

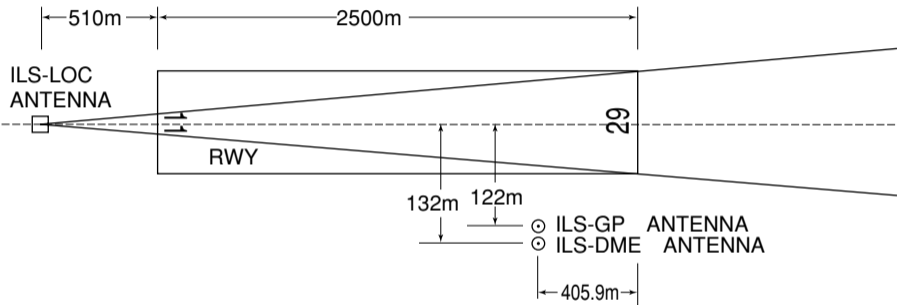

- REMARKS :
- |                         |             |
|-------------------------|-------------|
| 1. LOC beam BRG(MAG)    | 290°        |
| 2. HGT of ILS REF datum | 16.5m(54ft) |
| 3. GP angle             | 3.0°        |
| 4. ELEV of ILS-DME      | 6.7m(22ft)  |