

AD 2 AERODROMES

RJOH AD 2.1 AERODROME LOCATION INDICATOR AND NAME

RJOH - MIHO

RJOH AD 2.2 AERODROME GEOGRAPHICAL AND ADMINISTRATIVE DATA

1	ARP coordinates and site at AD	352936N/1331421E
2	Direction and distance from (city)	7.5nm NW YONAGO
3	Elevation/ Reference temperature	13ft / -
4	Geoid undulation at AD ELEV PSN	Nil
5	MAG VAR/ Annual change	Nil
6	AD Administration, address, telephone, telefax, telex, AFS, e-mail and/or Web-site addresses	Japan Air Self Defense Force. PUBLIC AD.
7	Types of traffic permitted(IFR/ VFR)	IFR/VFR
8	Remarks	Miho Airport Office(CAB) 2064-Sainokami-cho, Sakaiminato-city, Tottori, 684-0055 Japan Tel: 0859(45)6114, Fax: 0859(47)2050

RJOH AD 2.3 OPERATIONAL HOURS

1	AD Administration	H24
2	Customs and immigration	INTL SKED FLT hours only
3	Health and sanitation	INTL SKED FLT hours only
4	AIS Briefing Office	H24(CAB:Nil)
5	ATS Reporting Office(ARO)	Nil
6	MET Briefing Office	H24(KANSAI)
7	ATS	H24
8	Fuelling	2200-1300
9	Handling	2200-1300
10	Security	Scheduled flight only
11	De-icing	Nil
12	Remarks	HR of service at CAB OPS section 2200 - 1300(Daily)

RJOH AD 2.4 HANDLING SERVICES AND FACILITIES

1	Cargo-handling facilities	Deal with the weight thing to a Boeing 767-300 type
2	Fuel/ oil types	Fuel Grades : (CIV)JET A-1, (JSDF) JP-4, JP-4A
3	Fuelling facilities/ capacity	Fuel truck refueling(CIV)
4	De-icing facilities	Nil
5	Hangar space for visiting aircraft	Nil
6	Repair facilities for visiting aircraft	Nil
7	Remarks	Nil

RJOH AD 2.5 PASSENGER FACILITIES

1	Hotels	Nil
2	Restaurants	AVBL
3	Transportation	Railways, Buses and Taxis
4	Medical facilities	Nil
5	Bank and Post Office	Nil
6	Tourist Office	Information desk
7	Remarks	Nil

RJOH AD 2.6 RESCUE AND FIRE FIGHTING SERVICES

1	AD category for fire fighting	To be issued later
2	Rescue equipment	To be issued later
3	Capability for removal of disabled aircraft	To be issued later
4	Remarks	Nil

RJOH AD 2.7 SEASONAL AVAILABILITY-CLEARING

1	Types of clearing equipment	Snow remove equipments (JSDF):To be issued later *(CAB): Sprinkler equipment x 1 , Snow plow X 2, Tractor shovel X 1
2	Clearance priorities	To be issued later
3	Remarks	*For B1, B2 TWY and CIVIL APRON

RJOH AD 2.8 APRONS, TAXIWAYS AND CHECK LOCATIONS DATA

1	Apron surface and strength	Civil apron : PCN55/R/B/X/T
2	Taxiway width, surface and strength	MAIN TWY Width : 23m A1, A5 Width : 28.5m A2, A3, A4 Width : 34m B1, B2 Width : 34m, PCN62/F/B/X/T
3	ACL and elevation	Not available
4	VOR checkpoints	Not available
5	INS checkpoints	Spot NR 1 352958.57N 1331438.72E 2 352959.40N 1331440.76E 3 353000.23N 1331443.09E 4 353001.25N 1331445.59E 5 353002.09N 1331447.56E
6	Remarks	Nil

RJOH AD 2.9 SURFACE MOVEMENT GUIDANCE AND CONTROL SYSTEM AND MARKINGS

1	Use of aircraft stand ID signs, TWY guide lines and Visual docking/ parking guidance system of aircraft stands	Nil
2	RWY and TWY markings and LGT	RWY: RWY 07/25 (Marking) RWY designation, RWY CL, RWY THR, TDZ, RWY side stripe (LGT) REDL, RTHL, RENL, RWY DIST marker LGT TWY: (Marking) TWY side stripe, RWY HLDG PSN, Mandatory instruction(A1-A5 TWY), TWY CL(B1, B2 TWY) (LGT): TWY edge LGT, TWY CL LGT (B1, B2 TWY), Taxiing guidance sign(A1-A5 TWY and B1, B2 TWY)
3	Stop bars	Nil
4	Remarks	(Marking) Overrun area (LGT) APN flood LGT

RJOH AD 2.10 AERODROME OBSTACLES

RWY/Area affected	Obstacle type	Coordinates	Elevation	Markings/ LGT	Remarks
Nil					

RJOH AD 2.11 METEOROLOGICAL INFORMATION PROVIDED

1	Associated MET Office	KANSAI
2	Hours of service MET Office outside hours	H24(KANSAI)
3	Office responsible for TAF preparation Periods of validity	KANSAI 30 Hours
4	Trend forecast Interval of issuance	Nil
5	Briefing/ consultation provided	Briefing is available upon inquiry at KANSAI
6	Flight documentation Language(s) used	C En
7	Charts and other information available for briefing or consultation	S ₆ , U ₇ , U ₈₅ , U ₅ , U ₃ , U ₂₅ , U ₂ /T _r , P _S , P ₅ , P ₃ , P ₂₅ , P _{SWE} , P _{SWF} , P _{SWG} , P _{SWI} , P _{SWM} , P _{SW} (domestic), E, C, W _E , W _F , W _G , W _I , W, N
8	Supplementary equipment available for providing information	Doppler Radar for Airport Weather (See below figure)
9	ATS units provided with information	TWR, APP
10	Additional information (limitation of service, etc.)	Observation is made by the Ministry of Defense.

Airspace for the advisory service concerning low level wind shear

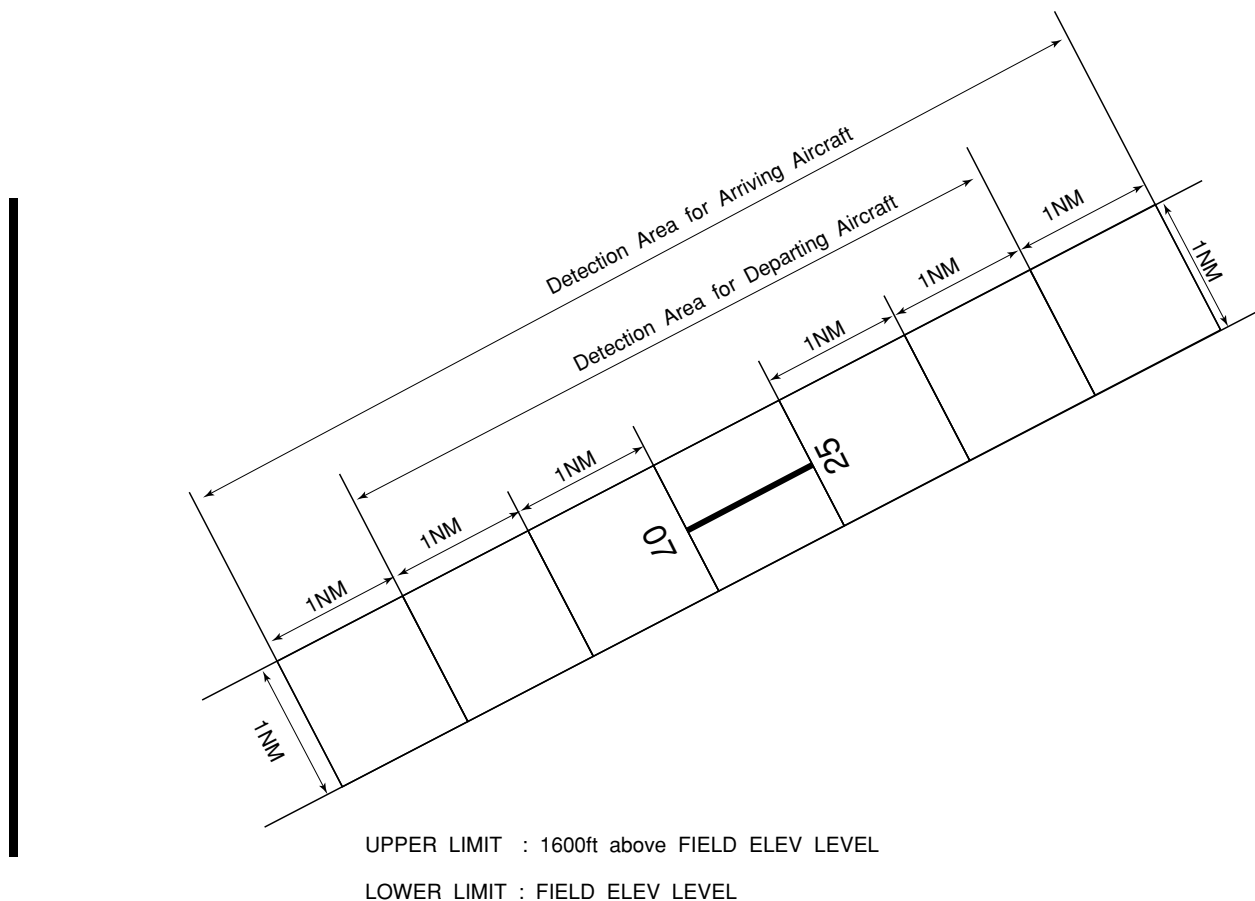

RJOH AD 2.12 RUNWAY PHYSICAL CHARACTERISTICS

Designations RWY NR	TRUE BRG	Dimensions of RWY(M)	Strength(PCN) and surface of RWY	THR coordinates THR geoid undulation	THR elevation and highest elevation of TDZ of precision APP RWY
1	2	3	4	5	6
07	063.74°	2500×45	PCN 70/F/A/X/T SW 82000kg (180779lbs) DW 89000kg (196211lbs)	Nil	THR ELEV: 9.3ft TDZ ELEV: 10.8ft
25	243.74°	2500×45	DTW 175000kg (385809lbs) TTTW 217000kg (478403lbs) Asphalt Concrete	Nil	THR ELEV: 20.4ft TDZ ELEV: 20.4ft
Slope of RWY		Strip Dimensions(M)	Remarks		
7		10	12		
See AD2.24 AD CHART		2620×300 2620×300	RWY Grooving:2500×30m		

RJOH AD 2.13 DECLARED DISTANCES

RWY Designator	TORA (m)	TODA (m)	ASDA (m)	LDA (m)	Remarks
1	2	3	4	5	6
07	2500	2500	2500	2500	Nil
25	2500	2500	2500	2500	Nil

RJOH AD 2.14 APPROACH AND RUNWAY LIGHTING

RWY Designator	APCH LGT type LEN INTST	RTHL Color WBAR	PAPI (VASIS) Angle DIST FM THR MEHT	RTZL LEN	RCLL LEN Spacing Color INTST	REDL LEN Spacing Color INTST	RENL Color WBAR	STWL LEN Color
1	2	3	4	5	6	7	8	9
07	SALS (*1) 420m		PAPI 3.0°/LEFT 422m 65.6ft	Nil	Nil			Nil (*2)
25	PALS (CAT I) 900m		PAPI 3.0°/LEFT 419m 66.0ft	Nil	Nil			Nil (*2)
Remarks								
10								
SALS with APCH LGT beacon(600m and 900m FM RWY 07 THR)(*1) Overrun area LGT(LEN:60M, Color:Red)(*2) CGL for RWY 07								

RJOH AD 2.15 OTHER LIGHTING, SECONDARY POWER SUPPLY

1	ABN/IBN location, characteristics and hours of operation	ABN: 352959N/1331354E, White/Green EV10sec, HO
2	LDI location and LGT Anemometer location and LGT	Nil
3	TWY edge and center line lighting	TWY edge LGT: Blue(B1, B2 TWY) TWY CL LGT: Green(B1, B2 TWY)
4	Secondary power supply/ switch-over time	10 sec :TWY edge LGT(B1, B2 TWY), TWY CL LGT(B1, B2 TWY)
5	Remarks	WDI LGT, OBST LGT

RJOH AD 2.16 HELICOPTER LANDING AREA

Nil

RJOH AD 2.17 ATS AIRSPACE

Designation and lateral limits		Vertical limits (ft)	Airspace classification	ATS unit call sign Language	Remarks
1		2	3	4	6
MIHO CTR	Area within radius of 5nm of MIHO ARP(35°30'N133°14'E)	3500 or below	D	MIHO TOWER En	
MIHO ACA	See attached chart		E	MIHO APP MIHO DEP MIHO RADAR En	

美保進入管制区
Miho Approach Control Area

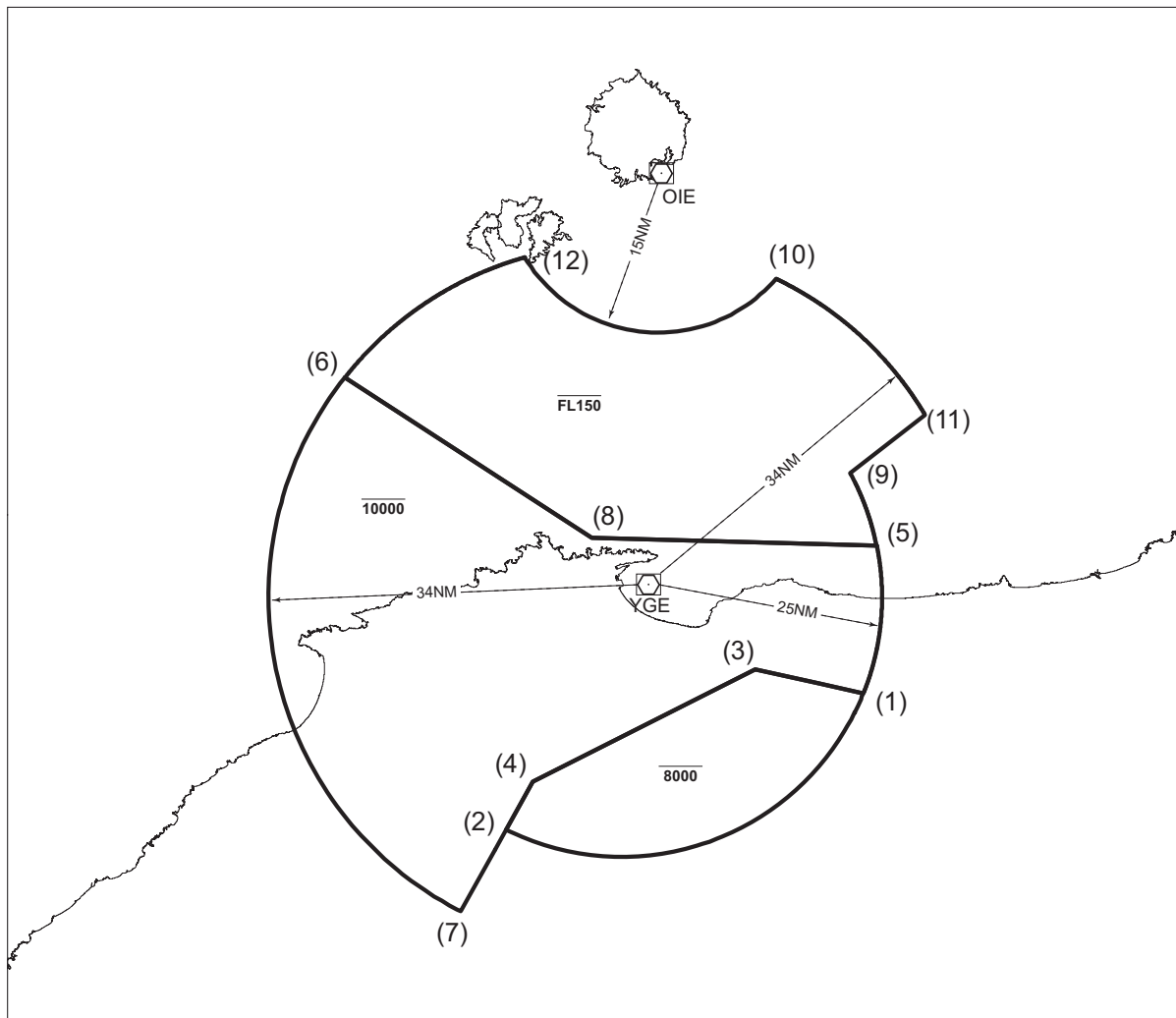

Point list

- (1) 352053N1334353E (7) 345939N1325649E
- (2) 350734N1330203E (8) 353546N1331150E
- (3) 352311N1333110E (9) 354209N1334218E
- (4) 351212N1330506E (10) 360049N1333325E
- (5) 353507N1334527E (11) 354745N1335107E
- (6) 355055N1324226E (12) 360244N1330336E

RJOH AD 2.18 ATS COMMUNICATION FACILITIES

Service designation	Call sign	Frequency	Hours of operation	Remarks
1	2	3	4	5
APP/ASR	Miho Approach/ Miho Radar	120.1MHz 125.4MHz 258.2MHz 317.8MHz 121.5MHz(E) 243.0MHz(E)	H24	ASR SERVICE 2200-1200 Other time 1HR PN
DEP	Miho Departure	120.1MHz 125.4MHz 258.2MHz 317.8MHz 121.5MHz(E) 243.0MHz(E)	2200 - 1200 Other time 1HR PN	
TWR	Miho Tower	236.8MHz 126.2MHz 302.4MHz 247.0MHz(1)(2) 123.1MHz(1)(2) 118.0MHz 243.0MHz(E) 121.5MHz(E)	H24	(1) For Rescue only. (2) AVBL on request.
GND	Miho Ground	275.8MHz 118.0MHz	H24	
MET	Miho Metro	344.6MHz	2030 - 1130 DLY except 2030 FRI - 1130 SAT, 2030 SAT - 1130 SUN, and HOL	Pilot forecaster SER(MIL)
GCA-ASR PAR	Miho Radar	335.6MHz 270.8MHz 134.1MHz 125.3MHz 228.2MHz 250.4MHz 289.4MHz 316.0MHz 141.8MHz 243.0MHz(E) 121.5MHz(E)	2200 - 1200 Other time 1HR PN	ASR RWY 07/25 PAR RWY 07/25 Glide path 3.0°

RJOH AD 2.19 RADIO NAVIGATION AND LANDING AIDS

Type of aid (VOR declination)	ID	Frequency	Hours of operation	Position of transmitting antenna coordinates	Elevation of DME transmitting antenna	Remarks
1	2	3	4	5	6	7
TACAN	JET	1201MHz (CH-114X)	H24	353151.77N/ 1330538.72E	1696ft	TACAN AZM unusable 010° BTN 10nm and 20nm BLW 12000ft. 167° BTN 10nm and 20nm BLW 12000ft.
VOR (8°W / 2020)	YGE	117.3MHz	H24	353004.96N/ 1331525.94E		VOR unusable: 360°-020° beyond 35nm BLW 4000ft. 120°-130° beyond 25nm BLW 8000ft. 290°-310° beyond 35nm BLW 4000ft. 330°-340° beyond 35nm BLW 4000ft.
DME	YGE	1207MHz (CH-120X)	H24	353004.96N/ 1331525.94E	43ft	DME unusable: 360°-040° beyond 35nm BLW 4000ft. 040°-060° beyond 30nm BLW 3000ft. 110°-120° beyond 35nm BLW 7000ft. 120°-130° beyond 25nm BLW 8000ft. 280°-310° beyond 25nm BLW 4000ft. 320°-330° beyond 25nm BLW 4000ft. 330°-340° beyond 30nm BLW 4000ft. 340°-350° beyond 25nm BLW 4000ft. 350°-360° beyond 20nm BLW 4000ft.
ILS-LOC 25	IYV	108.95MHz	2200 - 1300	352915.00N/ 1331328.21E		LOC: 235m away FM RWY 07 THR, BRG (MAG) 251°.
ILS-GP 25	-	329.15MHz	2200 - 1300	352952.93N/ 1331452.43E		GP:315m(1033ft) inside FM RWY 25 THR. 120m(394ft) N of RCL HGT of ILS Ref Datum 16.5m(54ft). Angle 3.0°
ILS-DME 25	IYV	1113MHz (CH-26Y)	2200 - 1300	352952.79N/ 1331452.07E	32ft	DME:325m(1066ft) inside FM RWY 25 THR. 120m(394ft) N of RCL.
MSAS		1575.42MHz	H24			Transmitting antennas are satellite based.

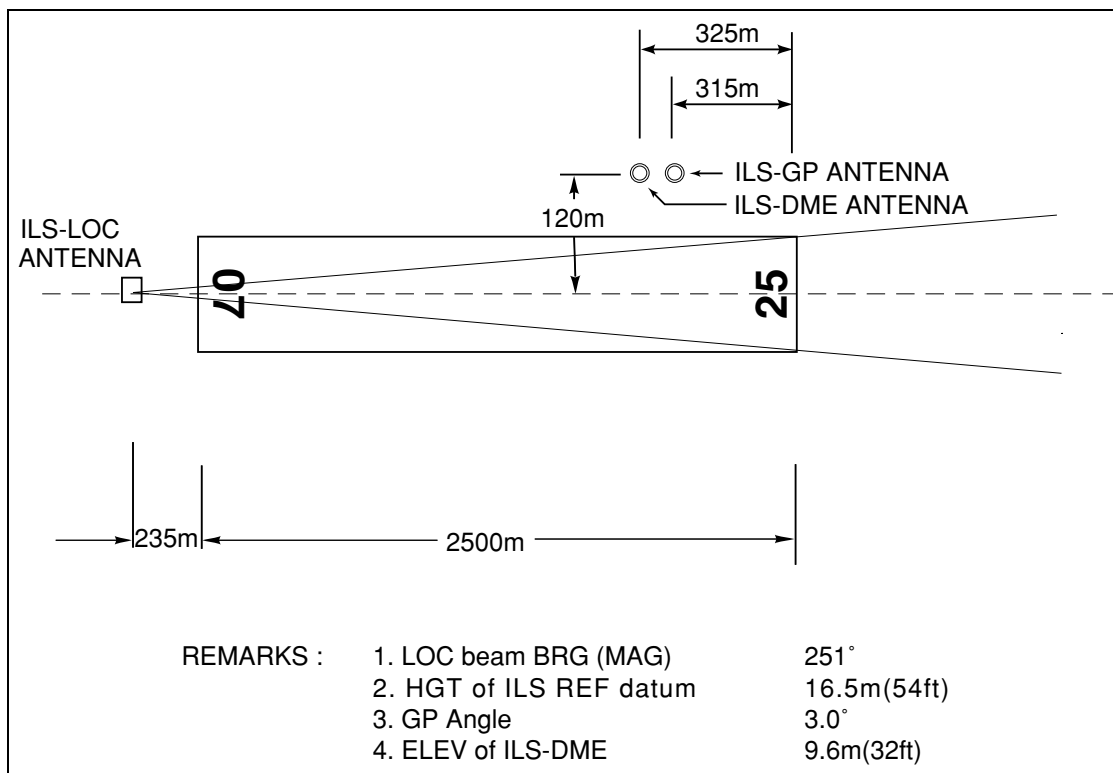

RJOH AD 2.20 LOCAL TRAFFIC REGULATIONS

1. Airport regulations

Civil transient aircraft:

- 1) PPR to CAB Miho Airport Office(0859-45-6114) for parking.
- 2) 2weeks PPR to 3rd Tactical Air Lift Wing Defense Division(0859-45-0211 EXT 232 or 236) for landing.
MON - FRI 2300-0800(except holiday)

2. Taxiing to and from stands

Nil

3. Parking area for small aircraft(General aviation)

Nil

4. Parking area for helicopters

Nil

5. Apron - taxiing during winter conditions

Nil

6. Taxiing - limitations

Nil

7. School and training flights - technical test flights - use of runways

Nil

8. Helicopter traffic - limitation

Nil

9. Removal of disabled aircraft from runways

Nil

RJOH AD 2.21 NOISE ABATEMENT PROCEDURES

Nil

RJOH AD 2.22 FLIGHT PROCEDURES

1. TAKE OFF MINIMA

	RWY	ACFT CAT	REDL & RCLL		REDL or RCLL or RCL Marking		NIL (DAYTIME ONLY)	
			RVR	VIS	RVR	VIS	RVR	VIS
Multi-Engine ACFT with TKOF ALTN AP FILED	07	A,B,C,D	-	-	400m	400m	-	500m
	25	A,B,C,D						
OTHER	07	A,B,C,D	AVBL LDG MINIMA					
	25	A,B,C,D						

2. WX MINIMA CONCERNING PAR/ASR APCH PROCEDURE

PAR RWY 07

PAR RWY 25

MINIMA		THR ELEV:9	AD ELEV: 13		MINIMA		THR ELEV:20	AD ELEV: 13	
CAT			CIRCLING		CAT			CIRCLING	
	DA(H)	RVR/ CMV	MDA(H)	VIS		DA(H)	RVR/ CMV	MDA(H)	VIS
A	211(202)	750	460(447)	1600	A	220(200)	750	460(447)	1600
B			470(457)		470(457)				
C			2400	C	2400				
D			570(557)	3200	D			570(557)	3200

ASR RWY 07

ASR RWY 25

MINIMA		THR ELEV:9	AD ELEV: 13		MINIMA		THR ELEV:20	AD ELEV: 13	
CAT			CIRCLING		CAT			CIRCLING	
	MDA(H)	RVR/ CMV	MDA(H)	VIS		MDA(H)	RVR/ CMV	MDA(H)	VIS
A	380(367)	1200	460(447)	1600	A	460(447)	900	460(447)	1600
B		1300	470(457)		B		1000	470(457)	
C		1400	2400	C	2400				
D		1600	570(557)	3200	D		1400	570(557)	3200

3. Lost communication procedures for arrival aircraft under radar navigational guidance

If radio communications with Miho Radar/GCA are lost for 1 minute or 5 seconds(PAR)/ 15 seconds(ASR) on final approach, squawk Mode A/3 Code 7600 and;

- (I) 1. Contact Miho Tower.
2. If unable, proceed in accordance with Visual Flight Rules.
3. If unable, proceed to YVE VOR/DME at last assigned altitude or 4,000ft whichever is higher, and execute instrument approach
- (II) Procedures other than above will be issued when situation required.

RJOH AD 2.23 ADDITIONAL INFORMATION

Nil

RJOH AD 2.24 CHARTS RELATED TO AN AERODROME

Aerodrome/Heliport Chart
Standard Departure Chart - Instrument (MIHO)
Standard Departure Chart - Instrument (YONAGO)
Standard Departure Chart - Instrument (INABA)
Standard Departure Chart - Instrument (SOUTH)
Standard Departure Chart - Instrument (DOZEN)
Standard Departure Chart - Instrument (STAGE-RNAV)
Standard Departure Chart - Instrument (USAGI-RNAV)
Standard Departure Chart - Instrument (KITARO-RNAV)

Standard Arrival Chart - Instrument (GAINA, KYURI-RNAV)
Instrument Approach Chart (ILS Z or LOC Z RWY25)
Instrument Approach Chart (ILS Y or LOC Y RWY25)
Instrument Approach Chart (ILS X or LOC X RWY25)

Instrument Approach Chart (VOR RWY25)

Instrument Approach Chart (VOR RWY07)

Instrument Approach Chart (TACAN A)
Instrument Approach Chart (RNAV(GNSS) RWY07)
Other Chart (MVA CHART)

INTENTIONALLY LEFT BLANK

RJOH / MIHO

AD CHART

CHANGE : VOR/DME deleted.

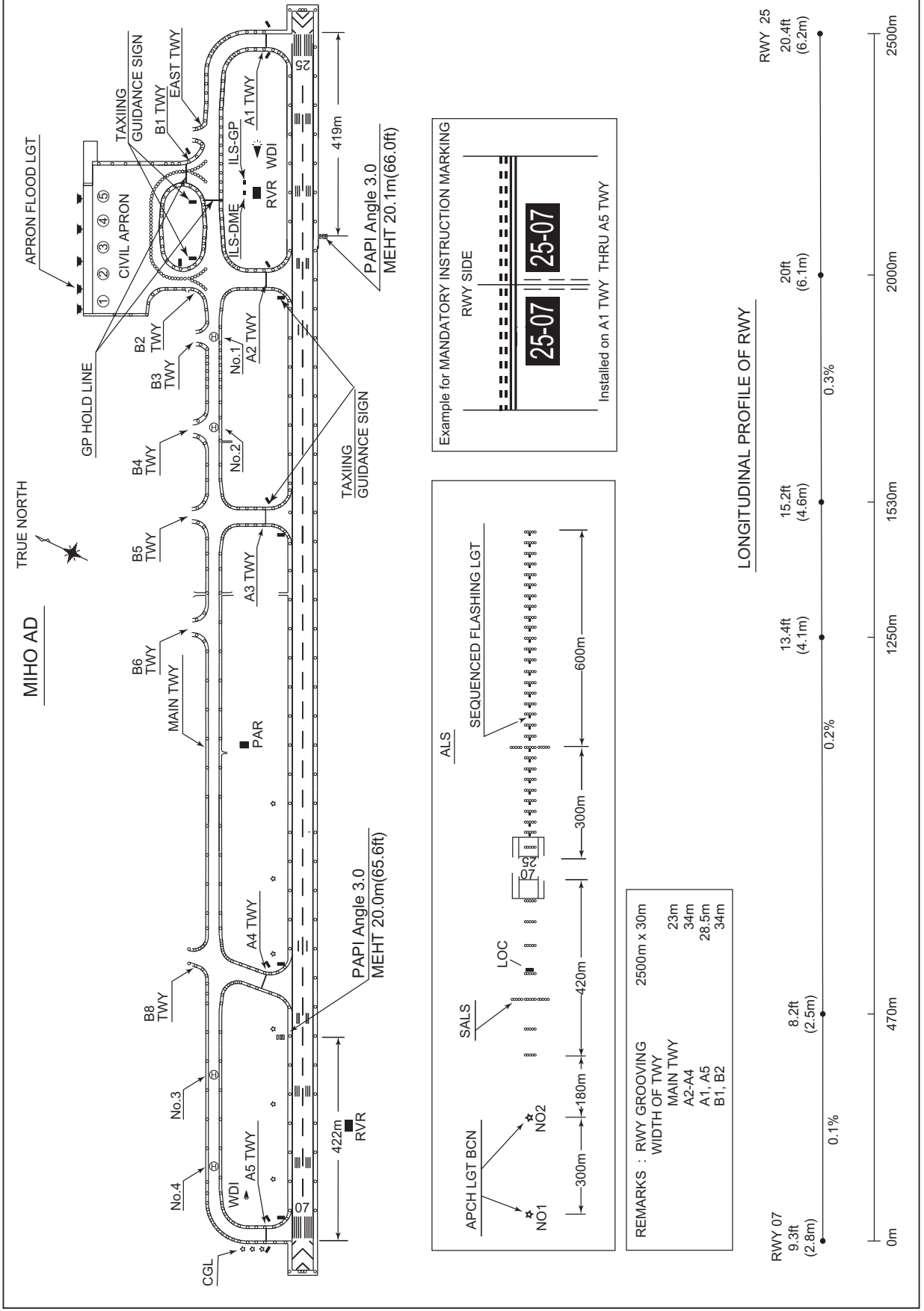

INSTRUMENT APPROACH CHART

RJOH / MIHO ILS Y or LOC Y RWY25

MIHO APP 120.1 – 125.4 258.2 – 317.8	ILS-LOC 108.95 IYV $\equiv\equiv$ -- ILS-GP 329.15 ILS-DME CH-26Y	MIHO TWR 236.8 - 126.2 275.8G	GCA AVBL CALL MIHO APP
--	--	-------------------------------------	------------------------------

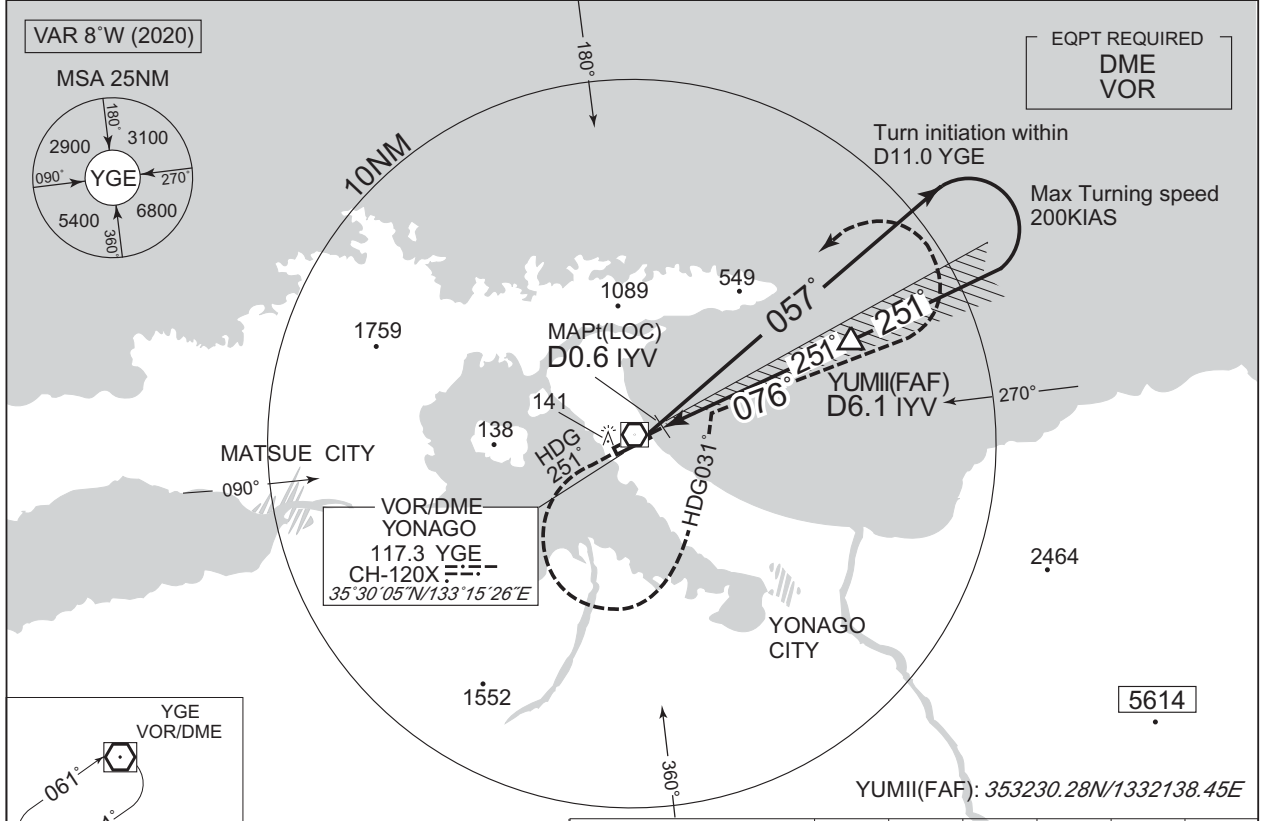

NM to IYV	MAPt	2	3	4	5	FAF
ALT (3.0° APCH Path)		652	970	1289	1607	1962

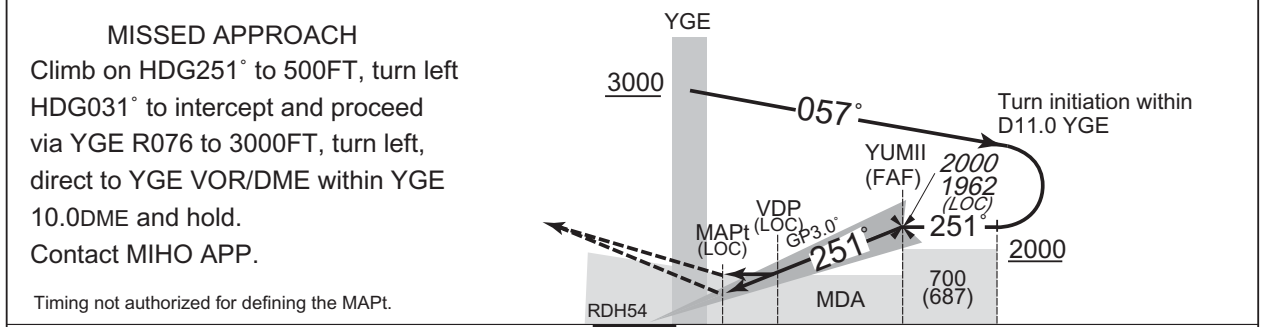

DME to IYV	0.2	0.6	1.0	6.1
NM to THR	0	0.4	0.9	5.9

Missed APCH climb gradient MNM 3.0%

MINIMA		THR elev. 20	AD elev. 13			
CAT	CAT I		LOC		CIRCLING	
	DA(H)	RVR/CMV	MDA(H)	RVR/CMV	MDA(H)	VIS
A	220 (200)	750	350 (337)	900	460 (447)	1600
B				1000	470 (457)	
C				1400	570 (557)	2400
D						3200

MINIMA with Missed APCH climb gradient of 2.5% are not established.

CHANGE : YONAGO VOR/DME. PROC course. YUMII established. VAR. MSA.

INSTRUMENT APPROACH CHART

RJOH / MIHO ILS X or LOC X RWY25

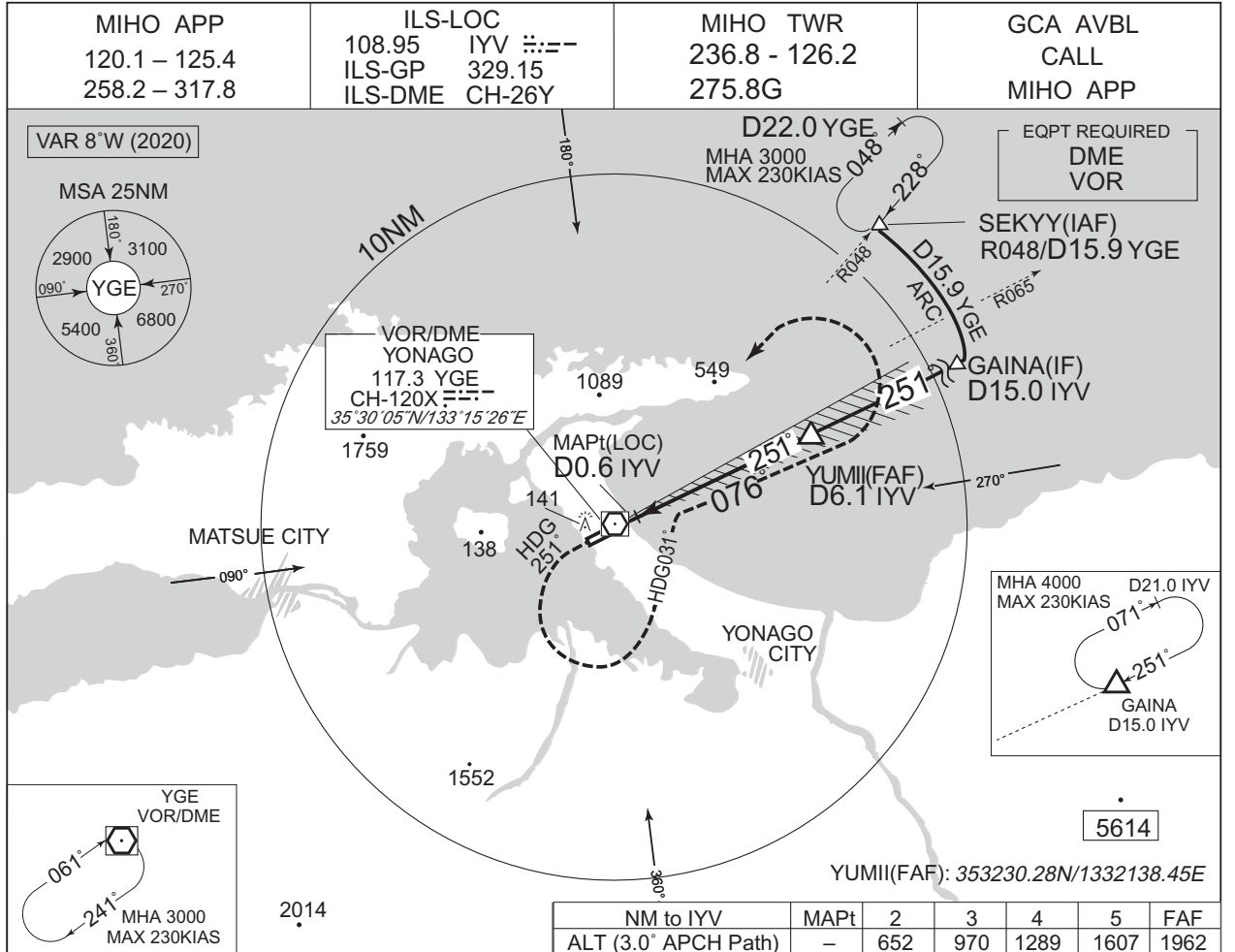

CHANGE : YONAGO VOR/DME. YUMII established. VAR. MSA.

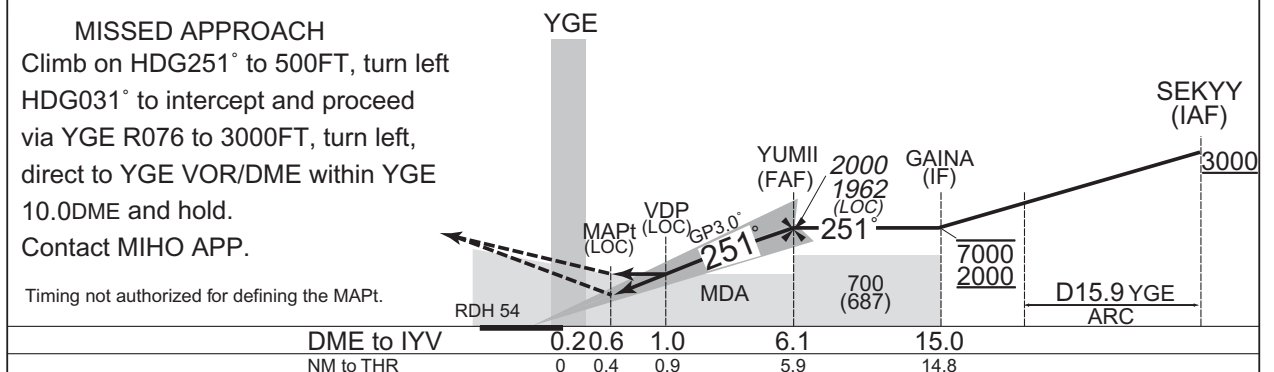

DME to IYV		0.2	0.6	1.0	6.1	15.0
NM to THR		0	0.4	0.9	5.9	14.8
Missed APCH climb gradient MNM 3.0%						
MINIMA		THR elev. 20		AD elev. 13		
CAT	CAT I		LOC		CIRCLING	
	DA(H)	RVR/CMV	MDA(H)	RVR/CMV	MDA(H)	VIS
A	220 (200)	750	350 (337)	900	460 (447)	1600
B				1000	470 (457)	
C				1400	570 (557)	2400
D						
MINIMA with Missed APCH climb gradient of 2.5% are not established.						

INSTRUMENT APPROACH CHART

RJOH / MIHO VOR RWY25

MIHO APP 120.1 – 125.4 258.2 – 317.8	YONAGO VOR/DME 117.3 YGE CH-120X $\equiv\equiv\equiv$ 35°30'05"N/133°15'26"E	MIHO TWR 236.8 - 126.2 275.8G	GCA AVBL CALL MIHO APP
--	---	-------------------------------------	------------------------------

VAR 8°W (2020)

EQPT REQUIRED
DME

YGE VOR/DME

NM to YGE	MAPt	1	2	3	4	FAF
ALT (3.0° APCH Path)	–	492	810	1129	1447	1766

MISSED APPROACH

Turn left HDG031° to intercept and proceed via YGE R076 to 3000FT, turn left, direct to YGE VOR/DME within YGE 10.0DME and hold. Contact MIHO APP.

Timing not authorized for defining the MAPt.

DME to/from YGE	0.3	0	0.8	5.0
NM to THR	0	0.3	1.1	5.3

MINIMA	THR elev. 20	AD elev. 13	
CAT	CIRCLING		
	MDA(H)	RVR/CMV	MDA(H) VIS
A	420 (407)	900	460 (447) 1600
B		1000	470 (457) 2400
C			570 (557) 3200
D	1400		

CHANGE : YONAGO VOR/DME. PROC renamed. PROC course. KOREI established. VAR. MSA.

INSTRUMENT APPROACH CHART

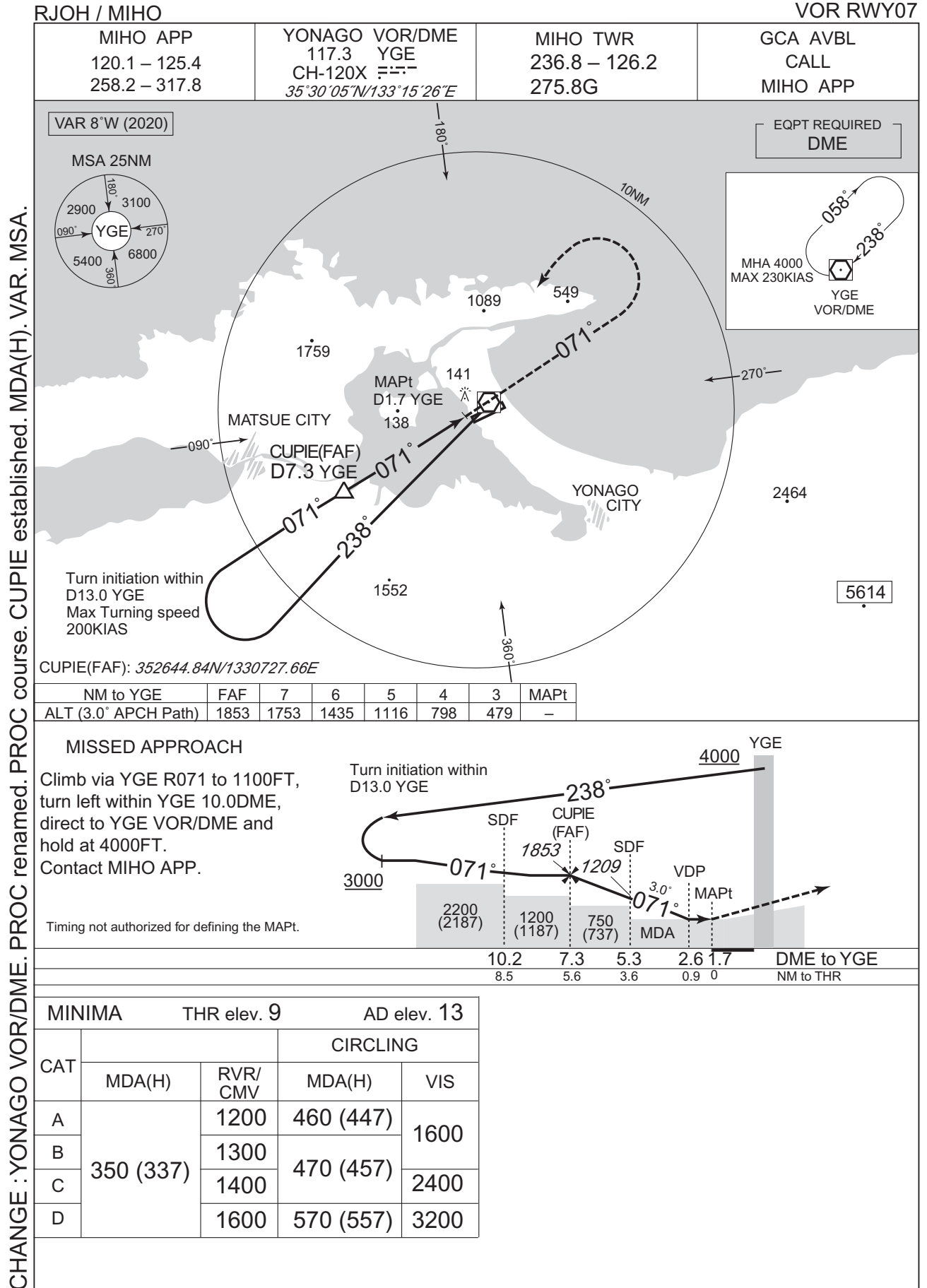

INSTRUMENT APPROACH CHART

RJOH / MIHO

TACAN A

MIHO APP 120.1 - 125.4 258.2 - 317.8	MIHO TACAN 1201 JET CH-114X 35°31'52"N/133°05'39"E	MIHO TWR 236.8 - 126.2 275.8G	GCA AVBL CALL MIHO APP
--	---	-------------------------------------	------------------------------

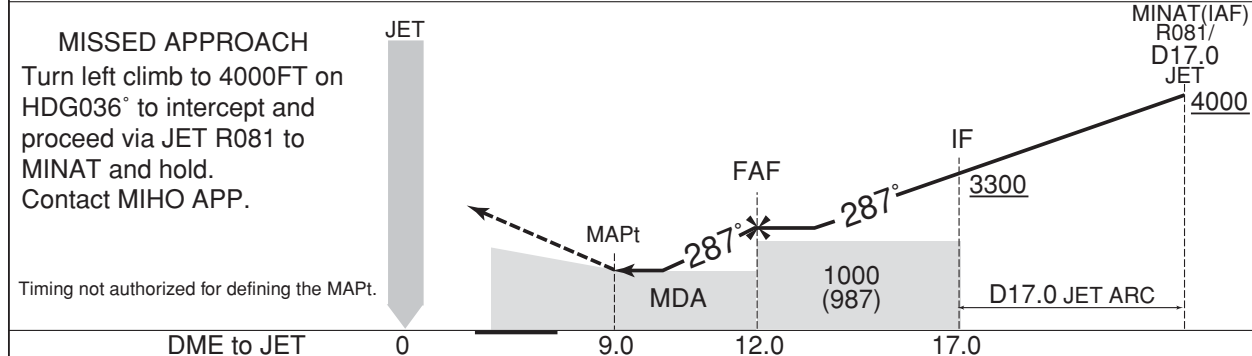
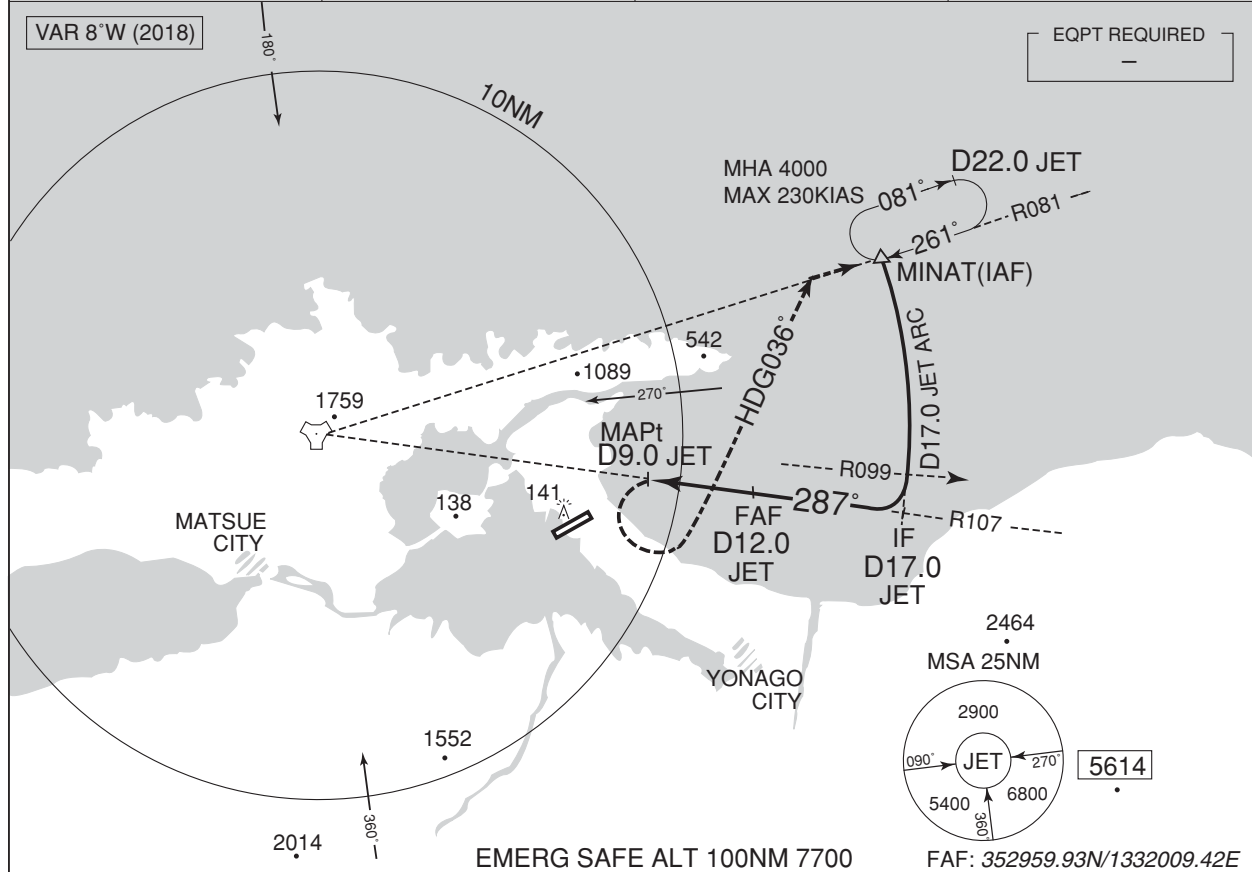

Missed APCH climb gradient MNM 5.0%

MINIMA		AD elev. 13
CAT	CIRCLING	
	MDA(H)	VIS
A	780 (767)	1600
B		2400
C		3200
D		

MINIMA with Missed APCH climb gradient of 2.5% are not established.

INSTRUMENT APPROACH CHART

RJOH / MIHO

RNAV(GNSS) RWY07

MIHO APP 120.1 – 125.4 258.2 – 317.8	1. DME/DME not authorized. 2. RADAR service required. 3. GNSS required.	MIHO TOWER 236.8 – 126.2 275.8G	GCA AVBL CALL MIHO APP
--	---	---------------------------------------	------------------------------

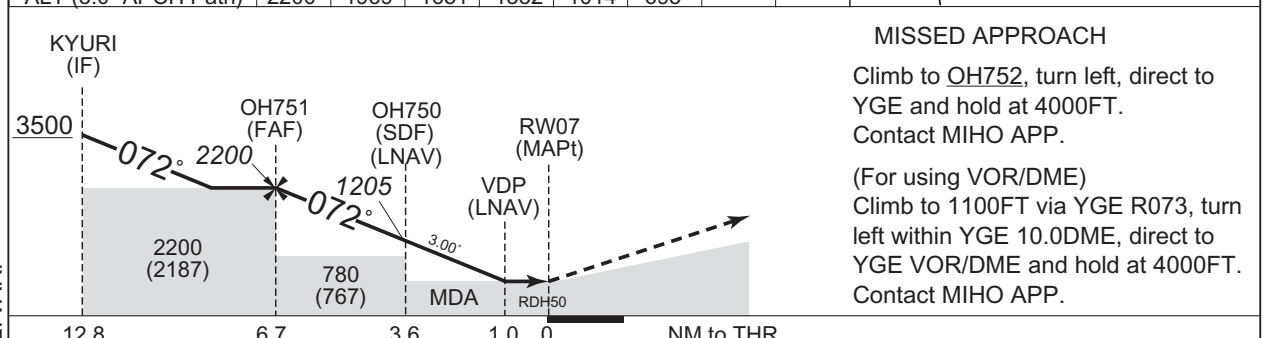
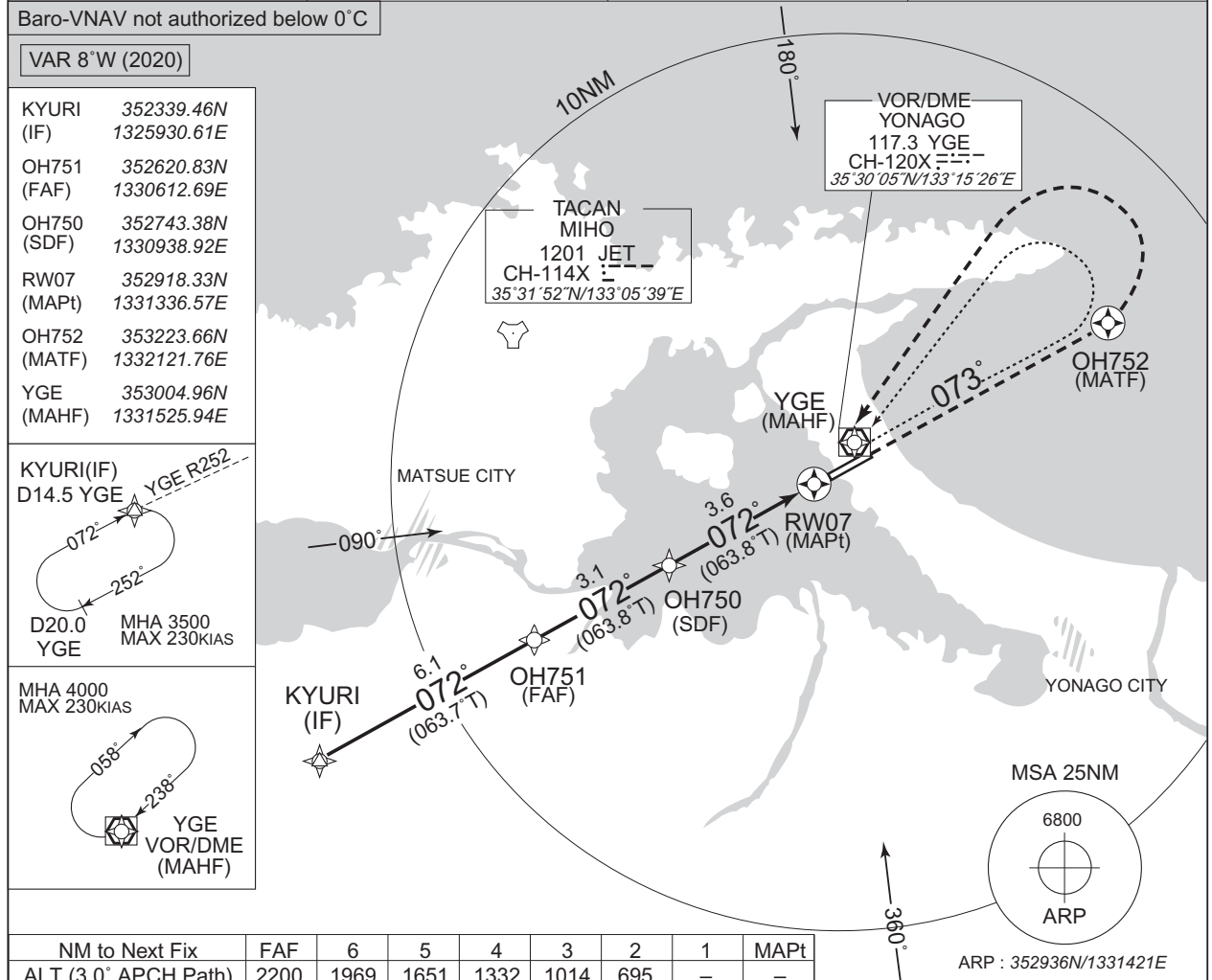

CHANGE : YONAGO VOR/DME. VAR.

MINIMA		THR elev. 9		AD elev. 13		
CAT	LNAV/VNAV		LNAV		CIRCLING	
	DA(H)	RVR/CMV	MDA(H)	RVR/CMV	MDA(H)	VIS
A	380 (371)	1200	380 (367)	1200	460 (447)	1600
B		1300		1300	470 (457)	
C		1400		1400		2400
D		1600		1600	570 (557)	3200

STANDARD DEPARTURE CHART - INSTRUMENT

RJOH / MIHO

SID

MIHO REVERSAL FIVE DEPARTURE

RWY 07 : Climb RWY HDG to 900FT, ...

RWY 25 : Climb RWY HDG to 500FT, ...

...turn left HDG026° to intercept and proceed via JET R071 to JET 23.0DME, turn left direct to JET TACAN.

Cross JET R071/19.0DME at or below 10000FT.

Note RWY25 : 5.0% climb gradient required up to 1200FT.

OBST ALT 1182FT located at 4.33NM 016° FM end of RWY25.

MIHO REVERSAL FIVE DEPARTURE

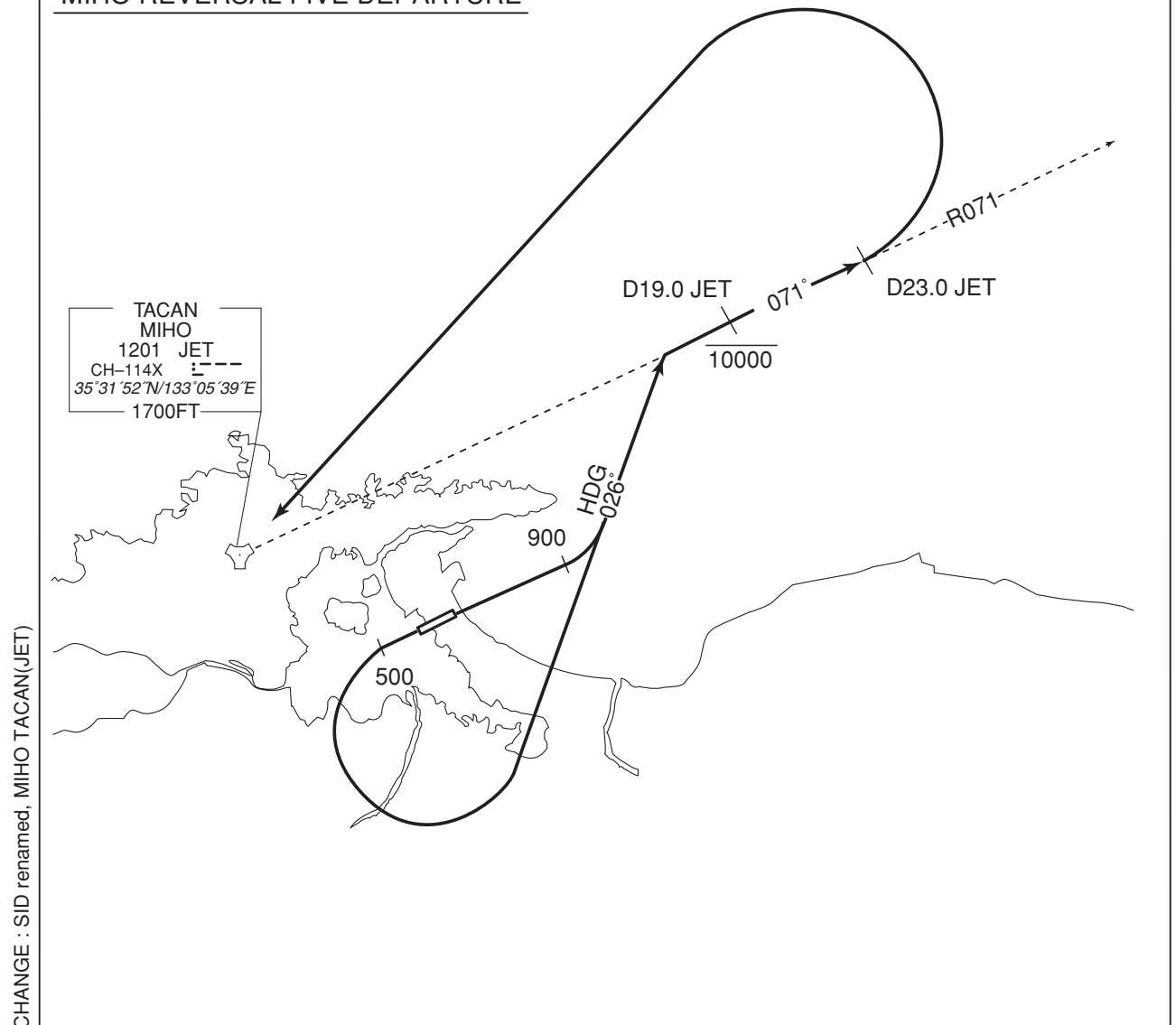

STANDARD DEPARTURE CHART - INSTRUMENT

RJOH / MIHO

RNAV SID

STAGE TWO DEPARTURE		RNAV1
Note 1) DME/DME/IRU or GNSS required. ※The aircraft equipped with only DME/DME/IRU must be able to update its position without delay at the starting point of take-off roll. 2) RADAR service required.	Critical DME	RWY07 : OIE : 12.6NM to STAGE - STAGE RWY25 : JET : 10.0NM to OH501 - 6.0NM to OH501 OIE : 6.0NM to OH501 -4.0NM to OH501 OH501 - OH701 12.6NM to STAGE - STAGE
	DME GAP	RWY07 :DER - 8.7NM to OH701 RWY25 :DER - 10.0NM to OH501
	Inappropriate Navaids	See AD1.1.6.10.3. Inappropriate NAVAIDs for RNAV1

VAR 8°W (2020)

STAGE TWO DEPARTURE

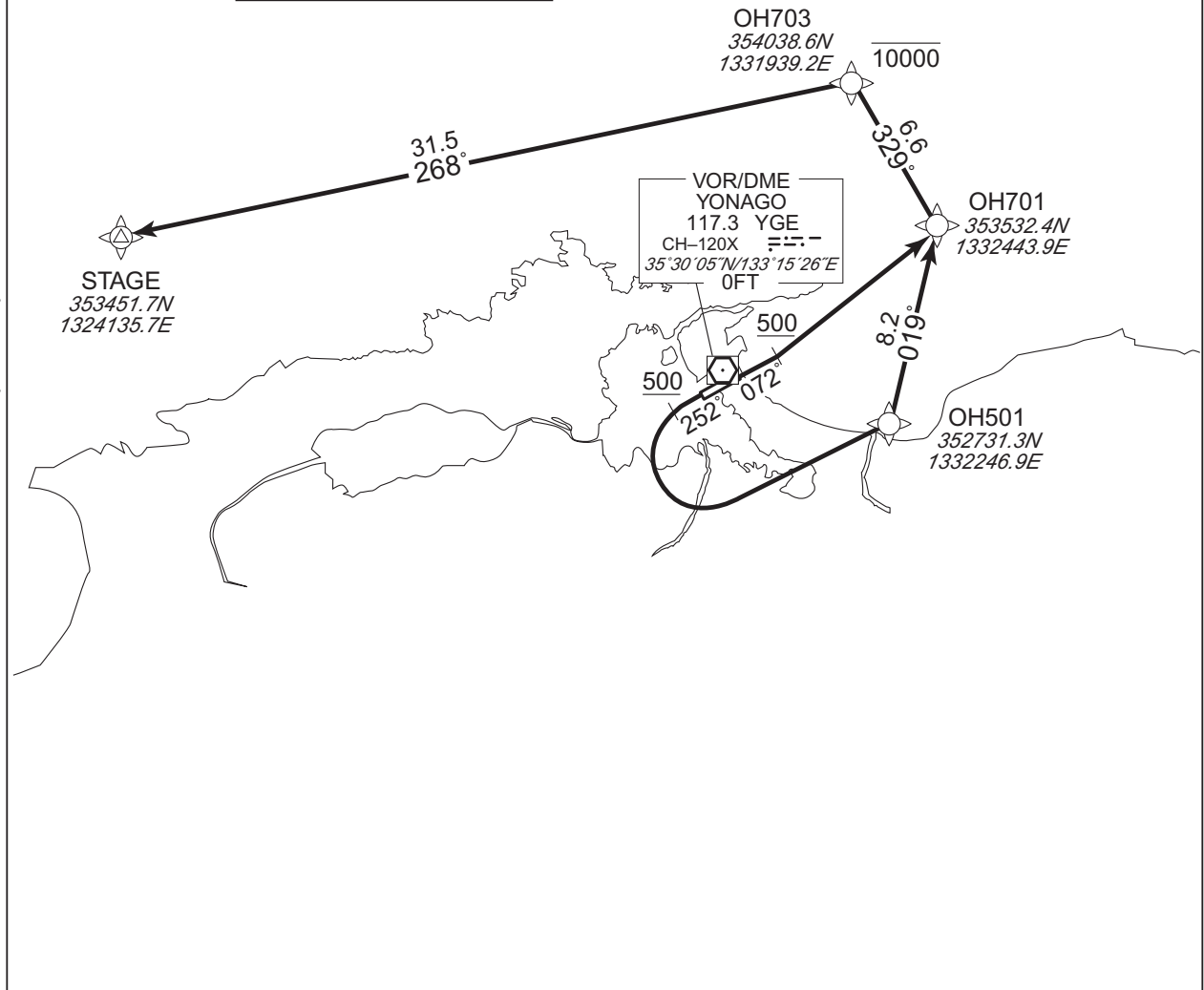

CHANGE : VAR. PROC renamed.PROC course. Note RWY25(OBST). YONAGO VOR/DME.

<u>STAGE TWO DEPARTURE</u>
RWY07 : Climb on HDG072° at or above 500FT, direct to OH701, to OH703 at or below 10000FT, to STAGE.
RWY25 : Climb on HDG252° at or above 500FT, turn left direct to OH501, to OH 701, to OH703 at or below 10000FT, to STAGE.
NOTE RWY25 : 5.0% climb gradient required up to 700FT. OBST ALT 1182FT located at 6.2NM 214° FM end of RWY25.

STANDARD DEPARTURE CHART - INSTRUMENT

RJOH / MIHO

RNAV SID

STAGE TWO DEPARTURE

RWY07

Serial Number	Path Descriptor	Waypoint Identifier	Fly Over	Course °M(°T)	Magnetic Variation	Distance (NM)	Turn Direction	Altitude (FT)	Speed (KIAS)	Vertical Angle	Navigation Specification
001	VA	—	—	072 (063.9)	-8.3	—	—	+500	—	—	RNAV1
002	DF	OH701	—	—	-8.3	—	—	—	—	—	RNAV1
003	TF	OH703	—	329 (321.1)	-8.3	6.6	—	-10000	—	—	RNAV1
004	TF	STAGE	—	268 (259.6)	-8.3	31.5	—	—	—	—	RNAV1

RWY25

Serial Number	Path Descriptor	Waypoint Identifier	Fly Over	Course °M(°T)	Magnetic Variation	Distance (NM)	Turn Direction	Altitude (FT)	Speed (KIAS)	Vertical Angle	Navigation Specification
001	VA	—	—	252 (243.9)	-8.3	—	—	+500	—	—	RNAV1
002	DF	OH501	—	—	-8.3	—	L	—	—	—	RNAV1
003	TF	OH701	—	019 (011.2)	-8.3	8.2	—	—	—	—	RNAV1
004	TF	OH703	—	329 (321.1)	-8.3	6.6	—	-10000	—	—	RNAV1
005	TF	STAGE	—	268 (259.6)	-8.3	31.5	—	—	—	—	RNAV1

CHANGE : VAR. PROC renamed, PROC course.

STANDARD DEPARTURE CHART - INSTRUMENT

RJOH / MIHO

RNAV SID

USAGI TWODEPARTURE

RNAV1

Note 1) DME/DME/IRU or GNSS required.
 ※The aircraft equipped with only DME/DME/IRU must be able to update its position without delay at the starting point of take-off roll.
 2) RADAR service required.

Critical DME

RWY25 :
 JET : 10.0NM to OH501 - 6.0NM to OH501
 OIE : 6.0NM to OH501 - 4.0NM to OH501
 OH501 - 6.0NM to YAPPA

DME GAP

RWY07 :DER - 8.7NM to OH701
 RWY25 :DER - 10.0NM to OH501

Inappropriate Nav aids

See AD1.1.6.10.3. Inappropriate NAV AIDs for RNAV1

VAR 8°W (2020)

USAGI TWO DEPARTURE

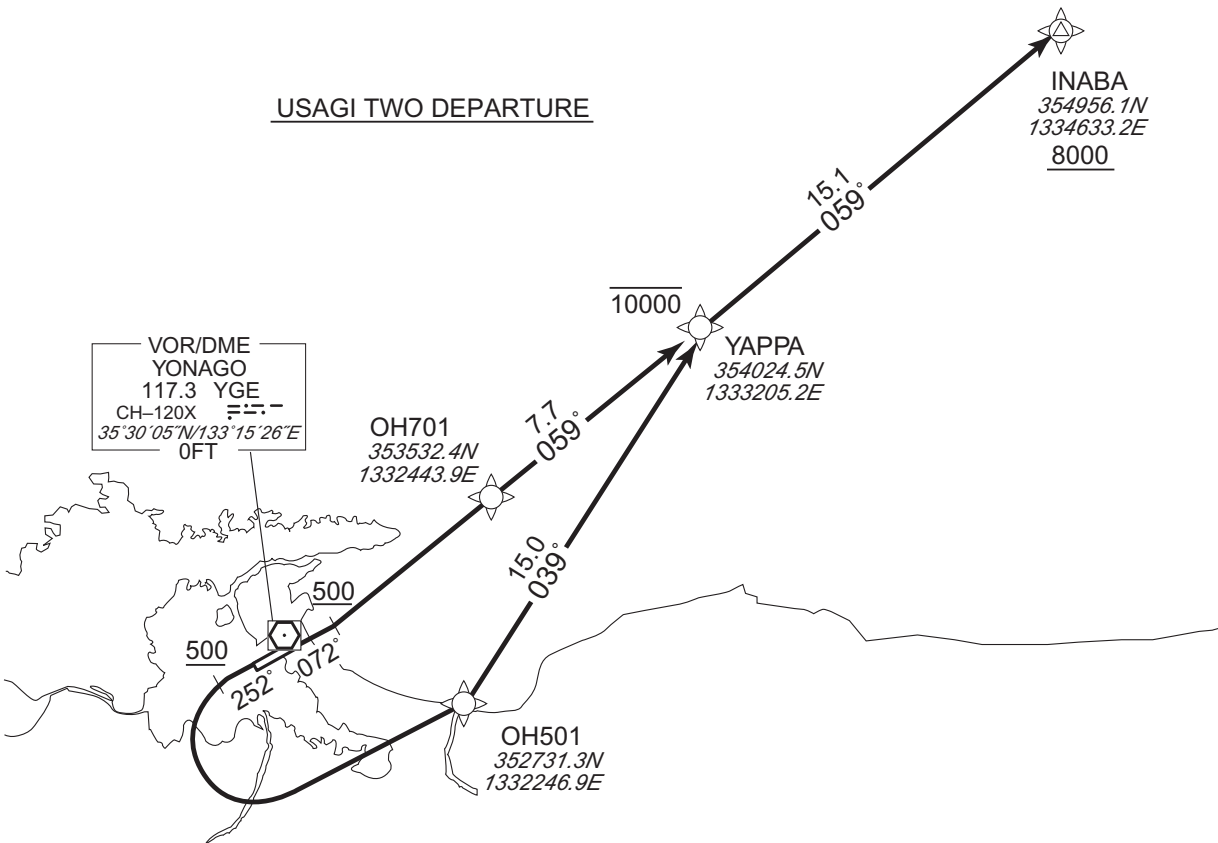

CHANGE : VAR. PROC renamed.PROC course. Note RWY25(OBST). YONAGO VOR/DME.

USAGI TWO DEPARTURE

RWY07 : Climb on HDG072° at or above 500FT, direct to OH701, to YAPPA at or below 10000FT, to INABA at or above 8000FT.

RWY25 : Climb on HDG252° at or above 500FT, turn left direct to OH501, to YAPPA at or below 10000FT, to INABA at or above 8000FT.

NOTE RWY25 : 5.0% climb gradient required up to 700FT.
 OBST ALT 1182FT located at 6.2NM 214° FM end of RWY25.

STANDARD DEPARTURE CHART - INSTRUMENT

RJOH / MIHO

RNAV SID

USAGI TWO DEPARTURE

RWY07

Serial Number	Path Descriptor	Waypoint Identifier	Fly Over	Course °M(°T)	Magnetic Variation	Distance (NM)	Turn Direction	Altitude (FT)	Speed (KIAS)	Vertical Angle	Navigation Specification
001	VA	—	—	072 (063.9)	-8.3	—	—	+500	—	—	RNAV1
002	DF	OH701	—	—	-8.3	—	—	—	—	—	RNAV1
003	TF	YAPPA	—	059 (050.8)	-8.3	7.7	—	-10000	—	—	RNAV1
004	TF	INABA	—	059 (050.9)	-8.3	15.1	—	+8000	—	—	RNAV1

RWY25

Serial Number	Path Descriptor	Waypoint Identifier	Fly Over	Course °M(°T)	Magnetic Variation	Distance (NM)	Turn Direction	Altitude (FT)	Speed (KIAS)	Vertical Angle	Navigation Specification
001	VA	—	—	252 (243.9)	-8.3	—	—	+500	—	—	RNAV1
002	DF	OH501	—	—	-8.3	—	L	—	—	—	RNAV1
003	TF	YAPPA	—	039 (030.4)	-8.3	15.0	—	-10000	—	—	RNAV1
004	TF	INABA	—	059 (050.9)	-8.3	15.1	—	+8000	—	—	RNAV1

CHANGE : VAR. PROC renamed. PROC course.

STANDARD DEPARTURE CHART - INSTRUMENT

RJOH / MIHO

RNAV TRANSITION

ALBINO TRANSITION		RNAV1
Note 1) DME/DME/IRU or GNSS required. 2) RADAR service required.	Critical DME	TRE : 42NM to MIYAZU - 40NM to MIYAZU OKT : 26NM to MIYAZU - 25NM to MIYAZU STD : 5NM to MIYAZU - 1NM to MIYAZU
	DME GAP	-
	Inappropriate NavAids	See AD1.1.6.10.3. Inappropriate NAVAIDs for RNAV1

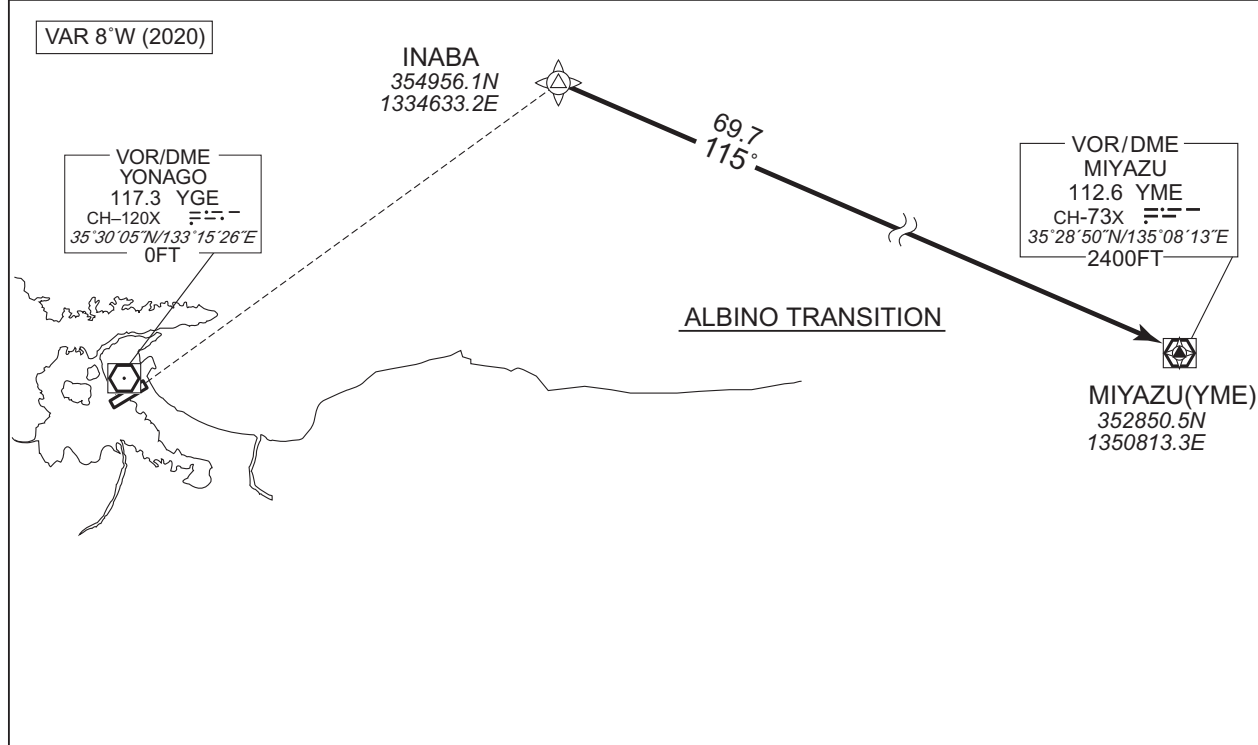

ALBINO TRANSITION
From INABA, to YME.

ALBINO TRANSITION

Serial Number	Path Descriptor	Waypoint Identifier	Fly Over	Course °M(°T)	Magnetic Variation	Distance (NM)	Turn Direction	Altitude (FT)	Speed (KIAS)	Vertical Angle	Navigation Specification
001	IF	INABA	-	-	-8.3	-	-	-	-	-	RNAV1
002	TF	YME	-	115 (107.2)	-8.3	69.7	-	-	-	-	RNAV1

CHANGE : VAR. YONAGO VOR/DME.

STANDARD DEPARTURE CHART - INSTRUMENT

RJOH / MIHO RNAV TRANSITION

KOMATSU TRANSITION		RNAV1
NOTE 1) DME/DME/IRU or GNSS required. 2) RADAR service required.	Critical DME	CBE : 3.0NM to KMC - KMC
	DME GAP	-
	Inappropriate Nav aids	See AD1.1.6.10.3. Inappropriate NAVAIDs for RNAV1

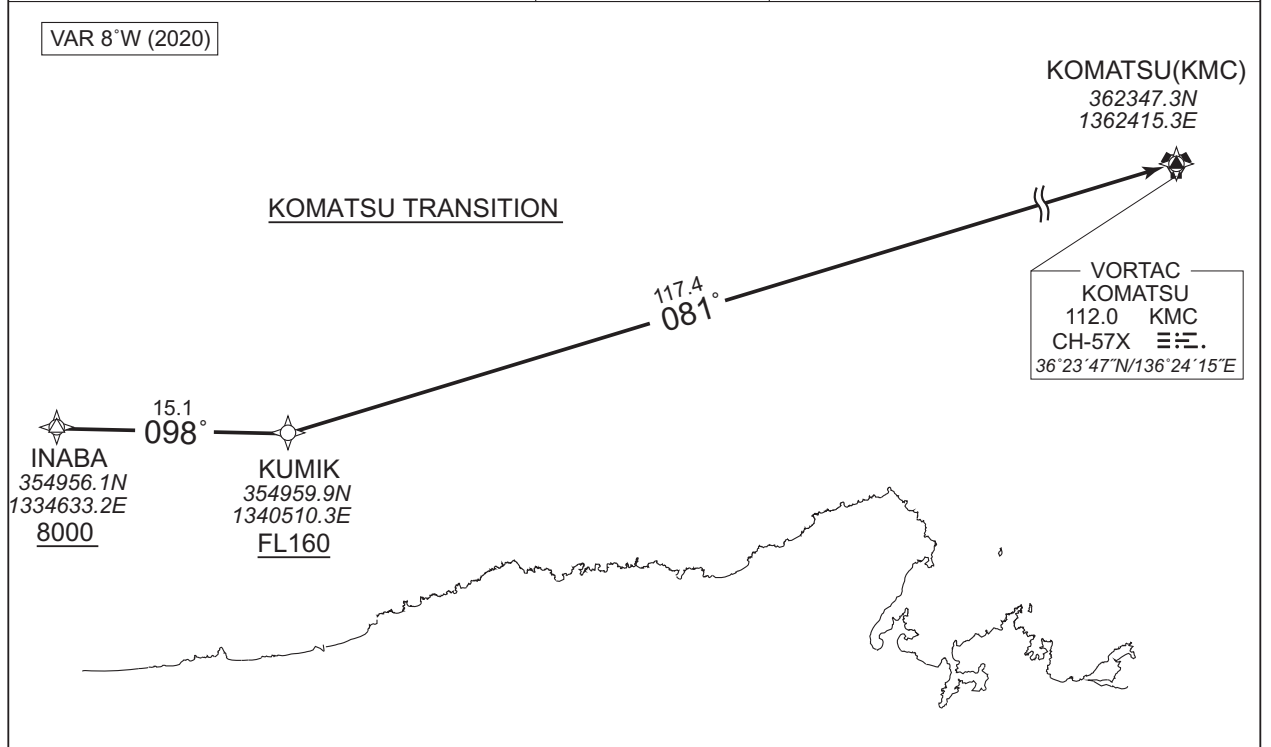

KOMATSU TRANSITION

From INABA at or above 8000FT, to KUMIK at or above FL160, to KMC.

Serial Number	Path Descriptor	Waypoint Identifier	Fly Over	Course °M(°T)	Magnetic Variation	Distance (NM)	Turn Direction	Altitude (FT)	Speed (KIAS)	Vertical Angle	Navigation Specification
001	IF	INABA	-	-	-8.3	-	-	+8000	-	-	RNAV1
002	TF	KUMIK	-	098 (089.7)	-8.3	15.1	-	+FL160	-	-	RNAV1
003	TF	KMC	-	081 (072.6)	-8.3	117.4	-	-	-	-	RNAV1

CHANGE : VAR.

STANDARD DEPARTURE CHART - INSTRUMENT

RJOH / MIHO

RNAV SID

KITARO TWO DEPARTURE		RNAV1
NOTE 1) DME/DME/IRU or GNSS required. ※The aircraft equipped with only DME/DME/IRU must be able to update its position without delay at the starting point of take-off roll. 2) RADAR service required.	Critical DME	RWY07 TRE : 1.0NM to OH703 – 7.0NM to MIHOU RWY25 JET : 10.0NM to OH501 – 6.0NM to OH501 OIE : 6.0NM to OH501 – 4.0NM to OH501 OH501 – OH701 TRE : 1.0NM to OH703 – 7.0NM to MIHOU
	DME GAP	RWY07 : DER – 8.7NM to OH701 RWY25 : DER – 10.0NM to OH501
	Inappropriate Nav aids	See AD1.1.6.10.3. Inappropriate NAVAIDs for RNAV1

VAR 8°W (2020)

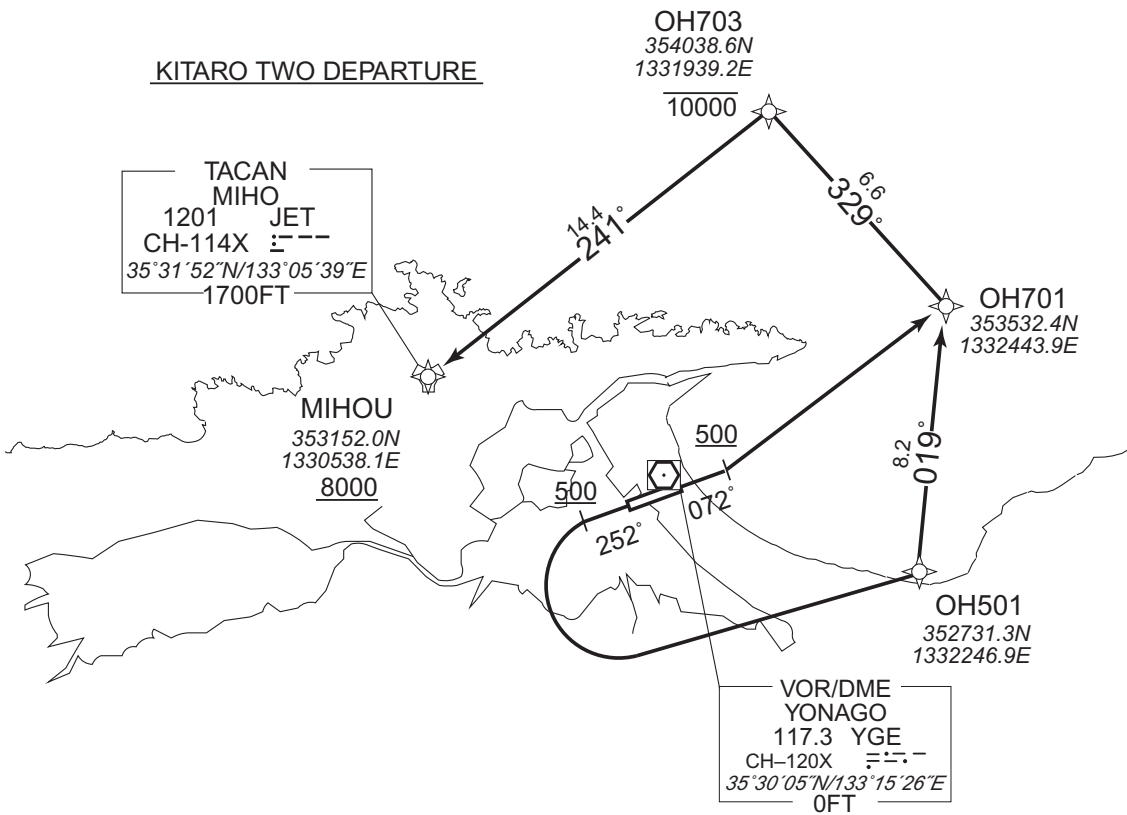

KITARO TWO DEPARTURE

RWY07 : Climb on HDG072° at or above 500FT, direct to OH701, to OH703 at or below 10000FT, to MIHOU at or above 8000FT.

RWY25 : Climb on HDG252° at or above 500FT, turn left direct to OH501, to OH701, to OH703 at or below 10000FT, to MIHOU at or above 8000FT.

NOTE RWY25 : 5.0% climb gradient required up to 700FT.

OBST ALT 1182FT located at 6.2NM 214° FM end of RWY25.

CHANGE: VAR. PROC renamed. Course FM OH703 to MIHOU. Note RWY25(OBST). YONAGO VOR/DME.

STANDARD DEPARTURE CHART - INSTRUMENT

RJOH / MIHO

RNAV SID

KITARO TWO DEPARTURE

RWY07

Serial Number	Path Descriptor	Waypoint Identifier	Fly Over	Course °M(°T)	Magnetic Variation	Distance (NM)	Turn Direction	Altitude (FT)	Speed (KIAS)	Vertical Angle	Navigation Specification
001	VA	-	-	072 (063.9)	-8.3	-	-	+500	-	-	RNAV1
002	DF	OH701	-	-	-8.3	-	-	-	-	-	RNAV1
003	TF	OH703	-	329 (321.1)	-8.3	6.6	-	-10000	-	-	RNAV1
004	TF	MIHOU	-	241 (232.5)	-8.3	14.4	-	+8000	-	-	RNAV1

RWY25

Serial Number	Path Descriptor	Waypoint Identifier	Fly Over	Course °M(°T)	Magnetic Variation	Distance (NM)	Turn Direction	Altitude (FT)	Speed (KIAS)	Vertical Angle	Navigation Specification
001	VA	-	-	252 (243.9)	-8.3	-	-	+500	-	-	RNAV1
002	DF	OH501	-	-	-8.3	-	L	-	-	-	RNAV1
003	TF	OH701	-	019 (011.2)	-8.3	8.2	-	-	-	-	RNAV1
004	TF	OH703	-	329 (321.1)	-8.3	6.6	-	-10000	-	-	RNAV1
005	TF	MIHOU	-	241 (232.5)	-8.3	14.4	-	+8000	-	-	RNAV1

CHANGE : VAR. PROC renamed. Course FM OH703 to MIHOU.

STANDARD ARRIVAL CHART - INSTRUMENT

RJOH / MIHO

RNAV STAR RWY25

GAINA EAST ARRIVAL

RNAV1

Note 1) DME/DME/IRU or GNSS required.
2) RADAR service required.

VAR 8°W (2020)

VOR/DME
YONAGO
117.3 YGE
CH-120X
35°30'05"N/133°15'26"E
0FT

GAINA
353623.5N
1333126.6E

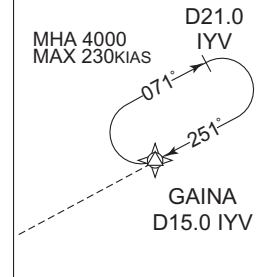

4000

7.7
321°

RAKDA
353110.1N
1333824.3E

GAINA EAST ARRIVAL

GAINA EAST ARRIVAL

From RAKDA, to GAINA at or above 4000FT.

Critical DME	OIE : RAKDA - 5.7NM to GAINA 3.7NM to GAINA - 1.7NM to GAINA
DME GAP	-
Inappropriate Nav aids	See AD1.1.6.10.3. Inappropriate NAVAIDs for RNAV1

CHANGE : VAR. Course FM RAKDA to GAINA. YONAGO VOR/DME.

Serial Number	Path Descriptor	Waypoint Identifier	Fly Over	Course °M(°T)	Magnetic Variation	Distance (NM)	Turn Direction	Altitude (FT)	Speed (KIAS)	Vertical Angle	Navigation Specification
001	IF	RAKDA	-	-	-8.3	-	-	-	-	-	RNAV1
002	TF	GAINA	-	321 (312.7)	-8.3	7.7	-	+4000	-	-	RNAV1

STANDARD ARRIVAL CHART - INSTRUMENT

RJOH / MIHO

RNAV STAR RWY25

GAINA WEST ARRIVAL

RNAV1

Note 1) DME/DME/IRU or GNSS required.
2) RADAR service required.

VAR 8°W (2020)

GAINA WEST ARRIVAL

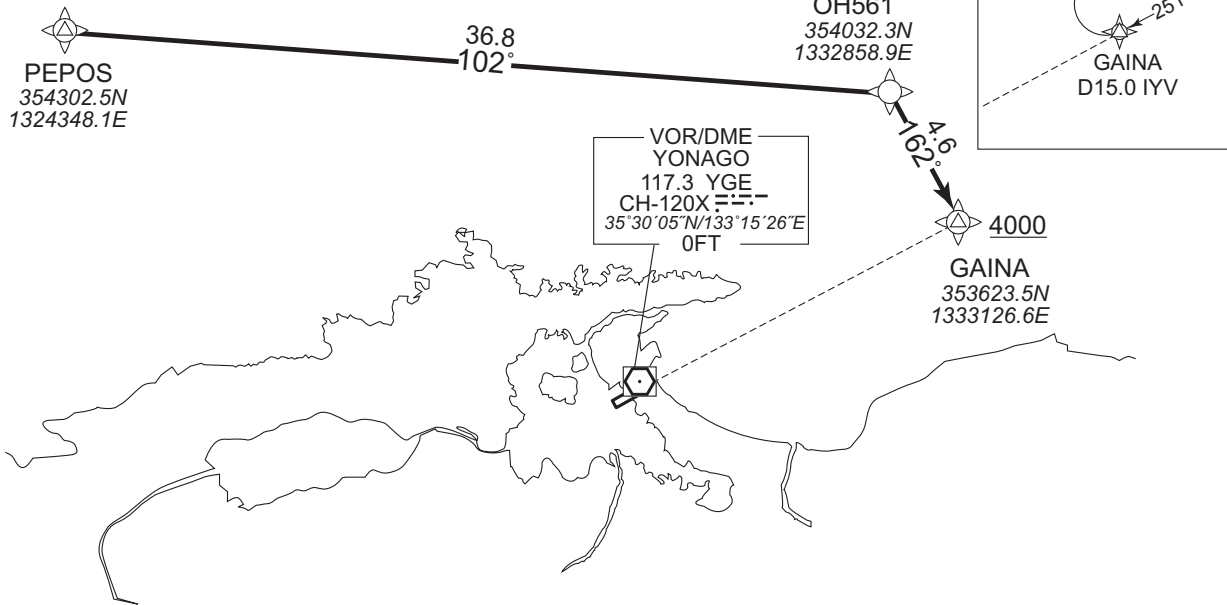

GAINA WEST ARRIVAL

From PEPOS, to OH561, to GAINA at or above 4000FT.

Critical DME	OIE : PEPOS - 32NM to OH561
DME GAP	-
Inappropriate Nav aids	See AD1.1.6.10.3. Inappropriate NAVAIDs for RNAV1

Serial Number	Path Descriptor	Waypoint Identifier	Fly Over	Course °M(°T)	Magnetic Variation	Distance (NM)	Turn Direction	Altitude (FT)	Speed (KIAS)	Vertical Angle	Navigation Specification
001	IF	PEPOS	-	-	-8.3	-	-	-	-	-	RNAV1
002	TF	OH561	-	102 (093.7)	-8.3	36.8	-	-	-	-	RNAV1
003	TF	GAINA	-	162 (154.2)	-8.3	4.6	-	+4000	-	-	RNAV1

CHANGE : VAR. Course FM PEPOS to OH561. YONAGO VOR/DME.

STANDARD ARRIVAL CHART - INSTRUMENT

RJOH / MIHO

RNAV STAR RWY07

KYURI EAST ARRIVAL

RNAV1

Note 1) DME/DME/IRU or GNSS required.
2) RADAR service required.

VAR 8°W (2020)

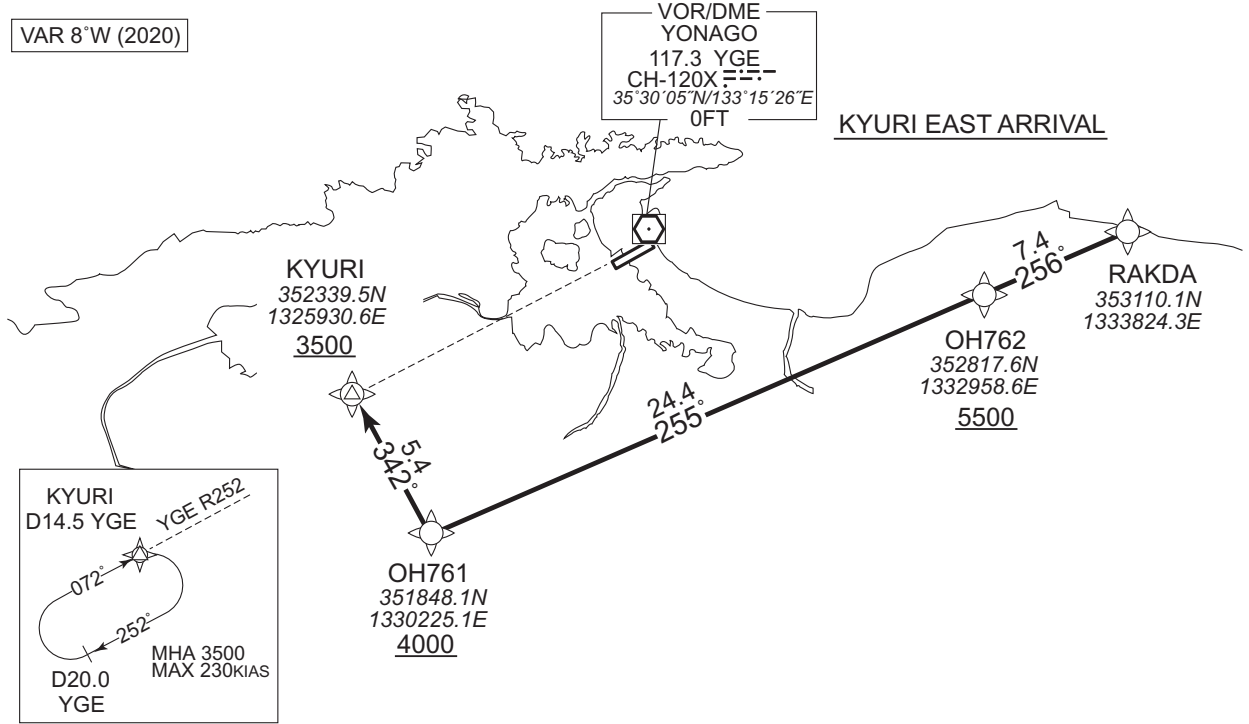

CHANGE : VAR. Course FM RAKDA to OH762. HLDG Pattern. Critical DME. DME GAP. YONAGO VOR/DME.

KYURI EAST ARRIVAL

From RAKDA, to OH762 at or above 5500FT, to OH761 at or above 4000FT, to KYURI at or above 3500FT.

Critical DME	—
DME GAP	—
Inappropriate Nav aids	See AD1.1.6.10.3. Inappropriate NAVAIDs for RNAV1

Serial Number	Path Descriptor	Waypoint Identifier	Fly Over	Course °M(°T)	Magnetic Variation	Distance (NM)	Turn Direction	Altitude (FT)	Speed (KIAS)	Vertical Angle	Navigation Specification
001	IF	RAKDA	—	—	-8.3	—	—	—	—	—	RNAV1
002	TF	OH762	—	256 (247.3)	-8.3	7.4	—	+5500	—	—	RNAV1
003	TF	OH761	—	255 (247.2)	-8.3	24.4	—	+4000	—	—	RNAV1
004	TF	KYURI	—	342 (334.0)	-8.3	5.4	—	+3500	—	—	RNAV1

STANDARD ARRIVAL CHART - INSTRUMENT

RJOH / MIHO

RNAV STAR RWY07

KYURI WEST ARRIVAL

RNAV1

Note 1) DME/DME/IRU or GNSS required.
2) RADAR service required.

VAR 8°W (2020)

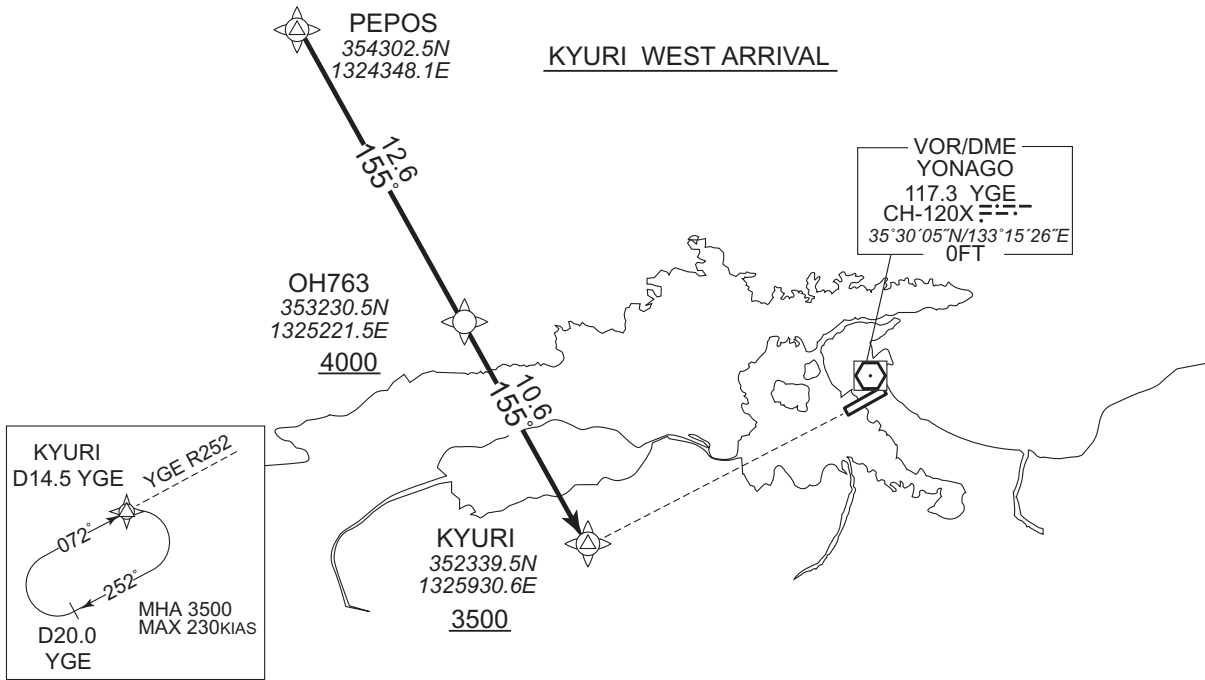

KYURI WEST ARRIVAL

From PEPOS, to OH763 at or above 4000FT, to KYURI at or above 3500FT.

Critical DME	OIE : 3NM to KYURI - 2NM to KYURI
DME GAP	-
Inappropriate Nav aids	See AD1.1.6.10.3. Inappropriate NAV AIDs for RNAV1

Serial Number	Path Descriptor	Waypoint Identifier	Fly Over	Course °M(T)	Magnetic Variation	Distance (NM)	Turn Direction	Altitude (FT)	Speed (KIAS)	Vertical Angle	Navigation Specification
001	IF	PEPOS	-	-	-8.3	-	-	-	-	-	RNAV1
002	TF	OH763	-	155 (146.5)	-8.3	12.6	-	+4000	-	-	RNAV1
003	TF	KYURI	-	155 (146.6)	-8.3	10.6	-	+3500	-	-	RNAV1

CHANGE : VAR, PROC course, HLDG Pattern, Critical DME, YONAGO VOR/DME.

RJOH / MIHO

Minimum Vectoring Altitude CHART

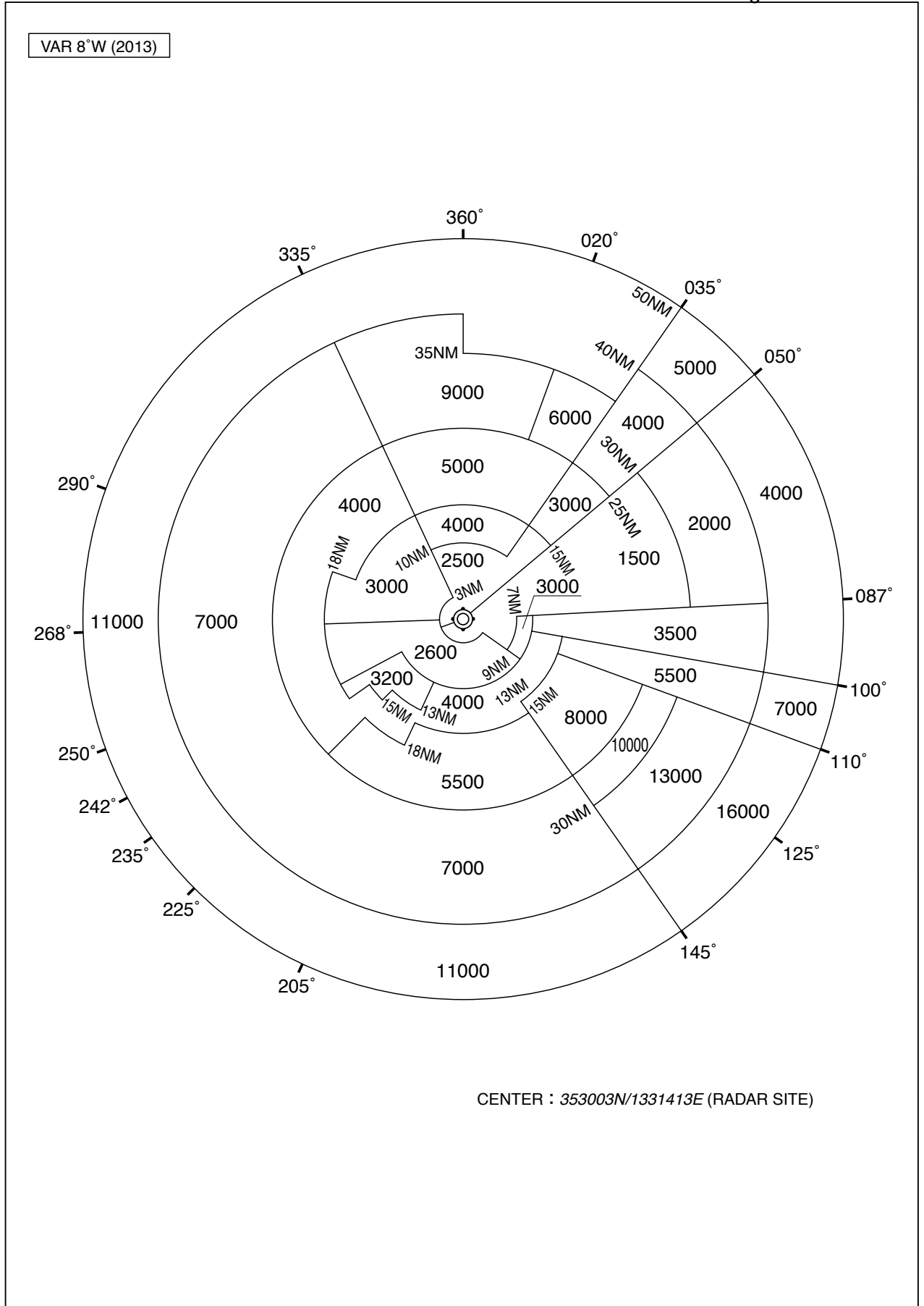

STANDARD DEPARTURE CHART - INSTRUMENT

RJOH / MIHO

SID

YONAGO REVERSAL SEVEN DEPARTURE

RWY 07 : Climb RWY HDG to 900FT, turn left ...

RWY 25 : Climb RWY HDG to 500FT, turn left HDG015° ...

... to intercept and proceed via YGE R060 to YGE 18.0DME, turn left direct to YGE VOR/DME.

Cross YGE R060/18.0DME at or below 10000FT.

Note RWY25 : 5.0% climb gradient required up to 700FT.

OBST ALT 1116FT located at 6.1NM 213° FM end of RWY25.

CHANGE : PROC renamed.PROC course. Note RWY25(OBST). YONAGO VOR/DME.

YONAGO REVERSAL SEVEN DEPARTURE

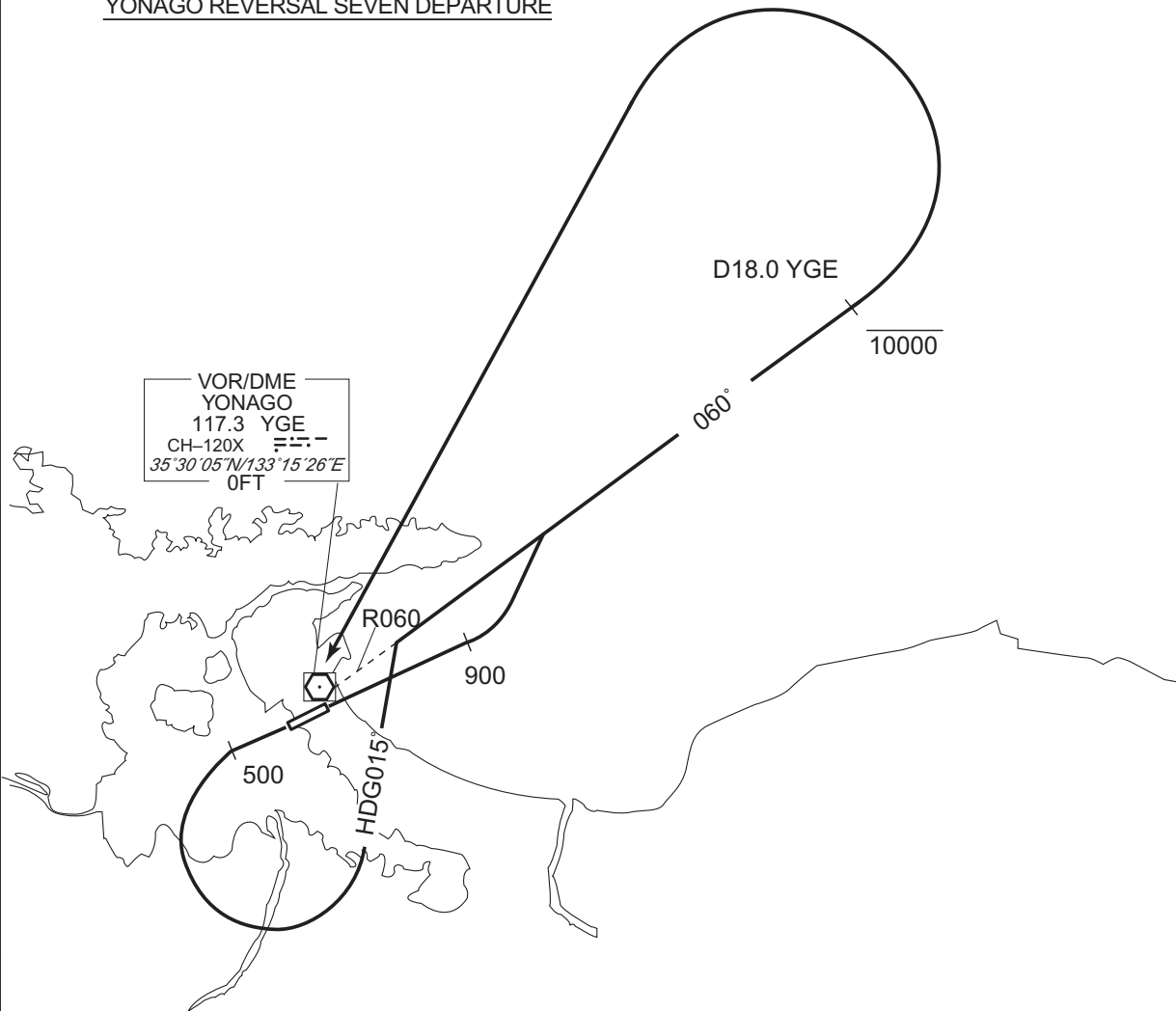

STANDARD DEPARTURE CHART -INSTRUMENT

RJOH / MIHO

SID and TRANSITION

INABA FIVE DEPARTURE

RWY07 : Climb RWY HDG to 900FT, turn left ...

RWY25 : Climb RWY HDG to 500FT, turn left HDG015° ...

... to intercept and proceed via YGE R060 to INABA.

Cross YGE R060/18.0DME (TRE R295) at or below 10000FT.

Cross INABA at or above 8000FT.

Note RWY25 : 5.0% climb gradient required up to 700FT.

OBST ALT 1116FT located at 6.1NM 213° FM end of RWY25.

TOZAN TRANSITION

From over INABA, proceed via TRE R322 to TRE VOR/DME, via TRE R142 to TOZAN.

MIYAZU TRANSITION

From over INABA, proceed via YME R296 to YME VOR/DME.

CHANGE : SID. Note RWY25(OBST). YONAGO VOR/DME.

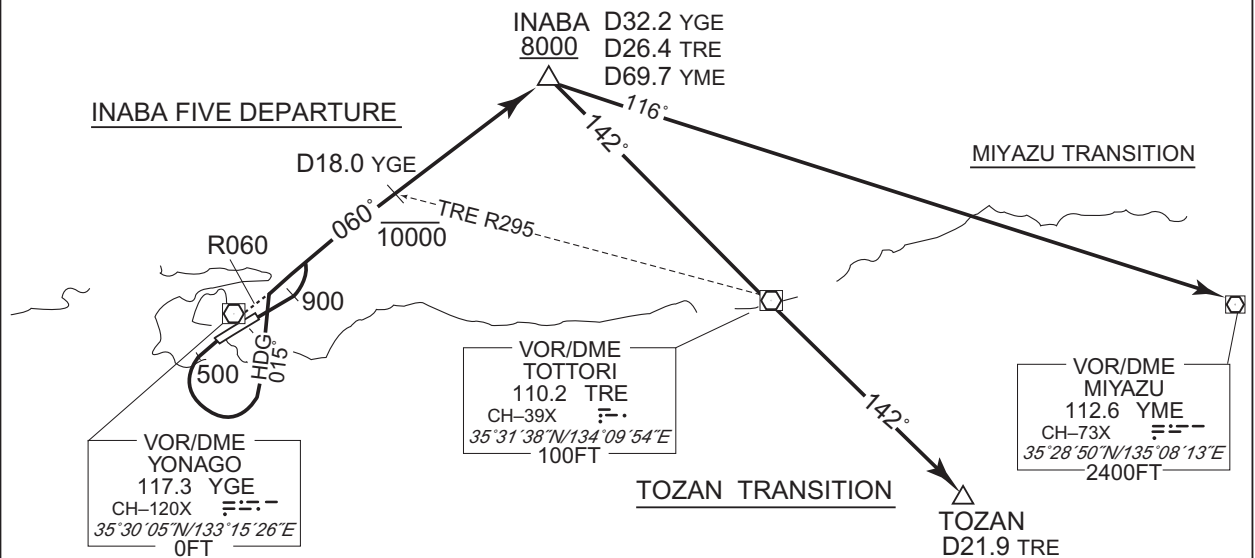

STANDARD DEPARTURE CHART - INSTRUMENT

RJOH / MIHO

SID and TRANSITON

SOUTH EIGHT DEPARTURE

RWY07 : Climb RWY HDG to 500FT, turn right HDG220° ...

RWY25 : Climb RWY HDG to 500FT, turn left HDG130° ...

... to intercept and proceed via YGE R175 to NIIMI.

Cross YGE R175/12.5DME at or below 10000FT,

Cross NIIMI at or above 6000FT.

Note RWY25 : 5.0% climb gradient required up to 700FT.

OBST ALT 1116FT located at 6.1NM 213° FM end of RWY25.

MIYOS TRANSITION

From over NIIMI, proceed via YGE 20.4DME clockwise ARC to intercept and proceed via YGE R218 to MIYOS.

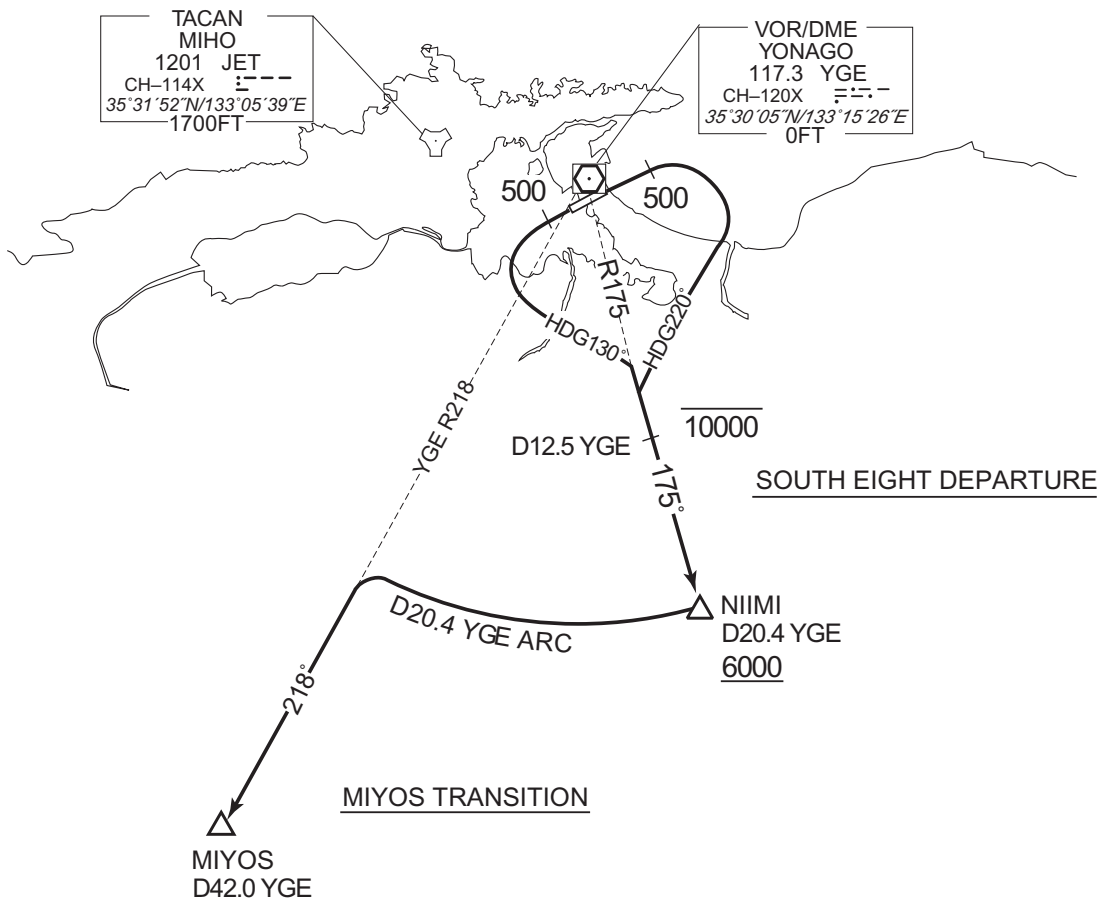

CHANGE : SID. Note RWY25(OBST). TRANSITION. YONAGO VOR/DME.

STANDARD DEPARTURE CHART - INSTRUMENT

RJOH / MIHO

SID

DOZEN SIX DEPARTURE

RWY 07 : Climb RWY HDG to 1000FT, turn left HDG322°...

RWY 25 : Climb RWY HDG to 500FT, turn left ...

... to intercept and proceed via YGE R007 to DOZEN.

Cross YGE R007/11.0DME between 6000FT and 10000FT.

Note RWY25 : 5.0% climb gradient required up to 1000FT.

OBST ALT 1182FT located at 4.3NM 016° FM end of RWY25.

CHANGE : PROC. Note RWY25. YONAGO VOR/DME.

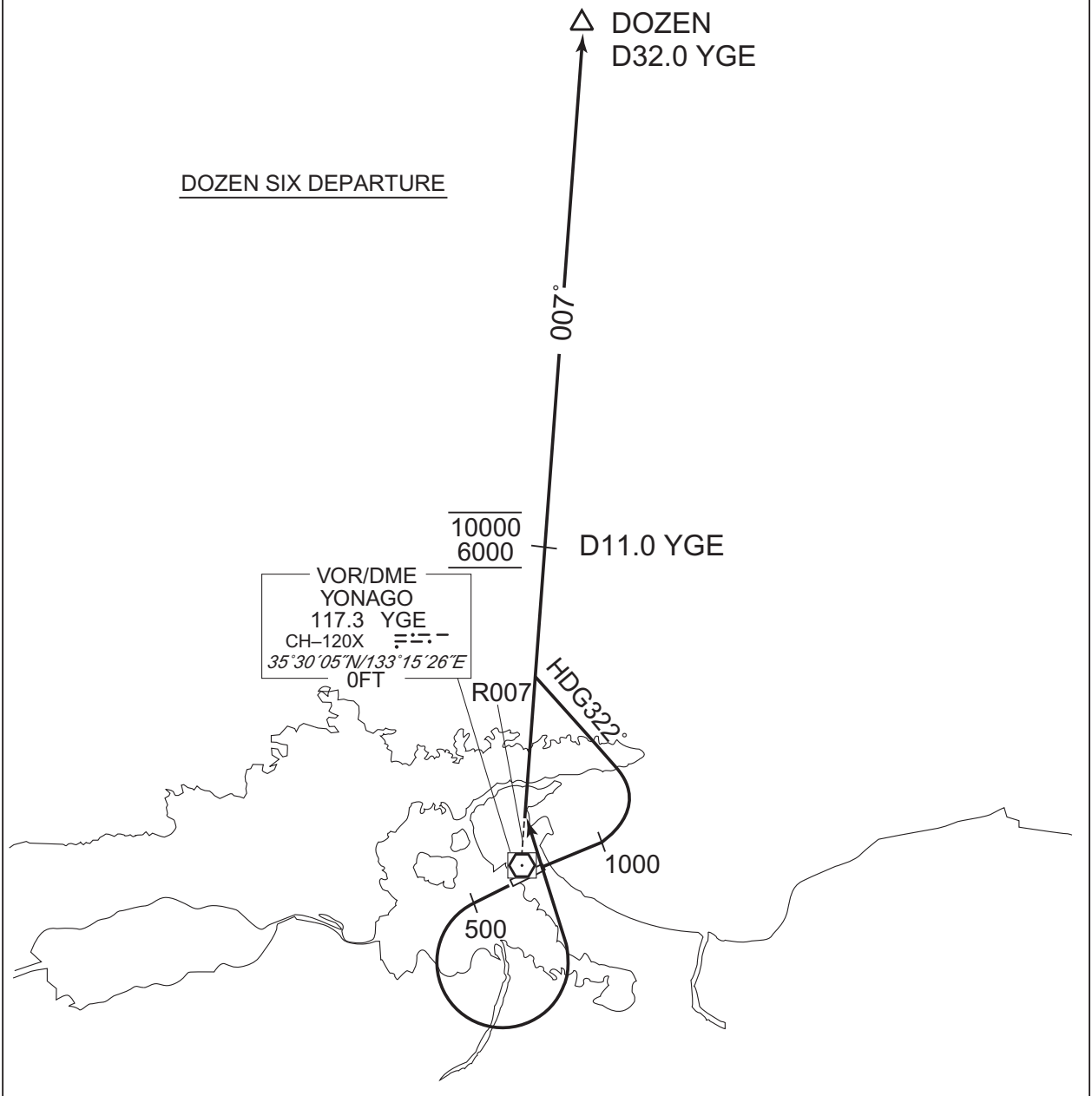

INSTRUMENT APPROACH CHART

RJOH / MIHO ILS Z or LOC Z RWY25

MIHO APP 120.1 - 125.4 258.2 - 317.8	ILS-LOC 108.95 IYV $\equiv\equiv\equiv$ ILS-GP 329.15 ILS-DME CH-26Y	MIHO TWR 236.8 - 126.2 275.8G	GCA AVBL CALL MIHO APP
--	---	-------------------------------------	------------------------------

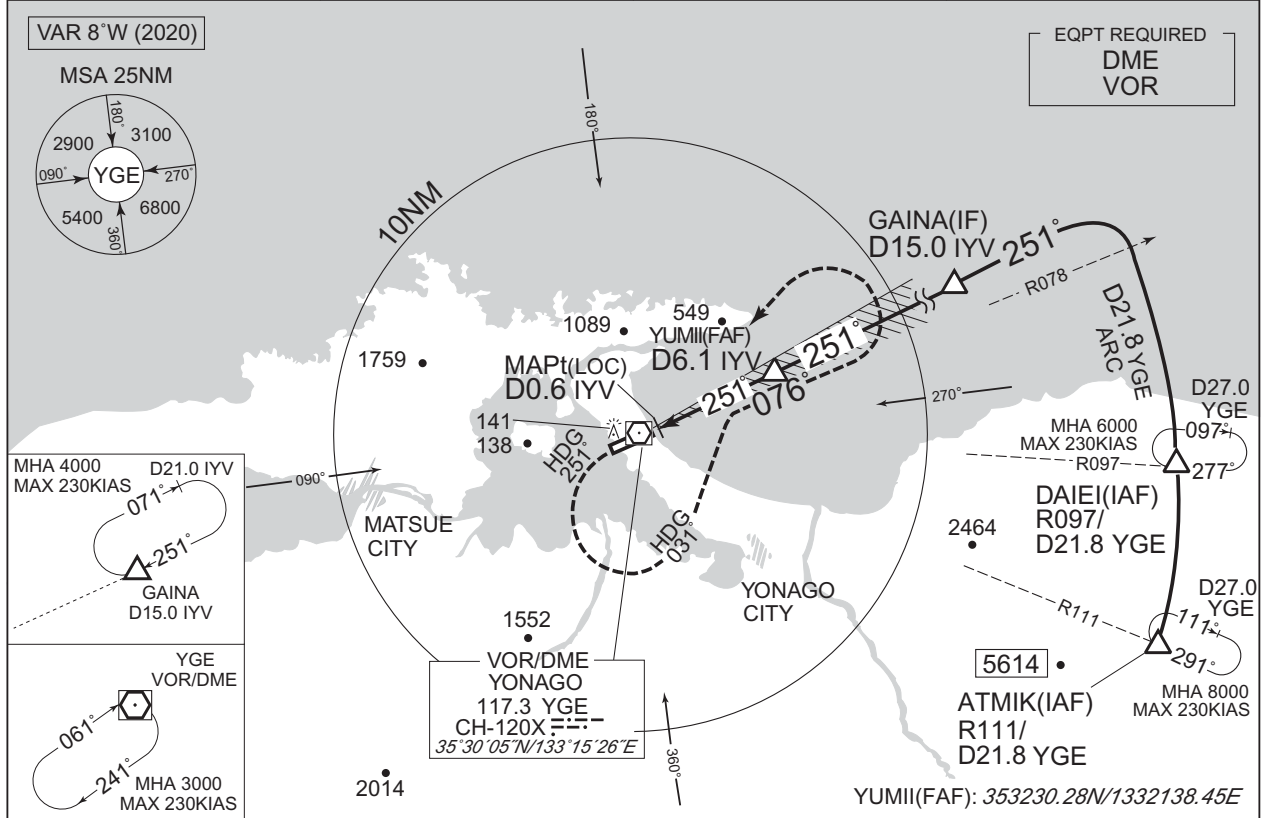

CHANGE : YONAGO VOR/DME. IAF (KRAYO) → ATMIK. YUMII established. VAR. MSA.

NM to IYV	MAPt	2	3	4	5	FAF
ALT (3.0° APCH Path)	-	652	970	1289	1607	1962

MISSED APPROACH
Climb on HDG251° to 500FT, turn left HDG031° to intercept and proceed via YGE R076 to 3000FT, turn left, direct to YGE VOR/DME within YGE 10.0DME and hold.
Contact MIHO APP.
Timing not authorized for defining the MAPt.

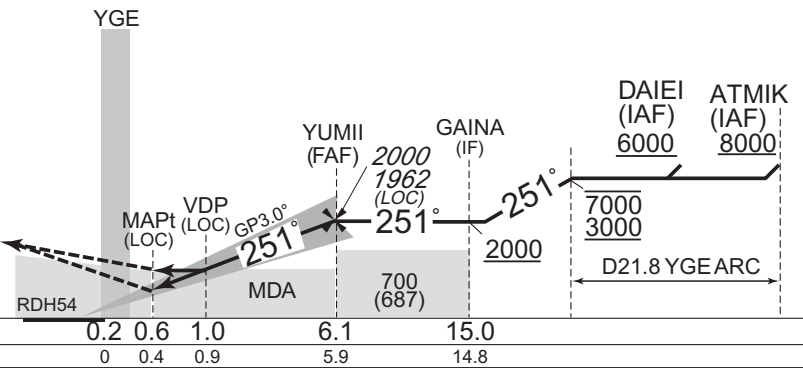

Missed APCH climb gradient MNM 3.0%

CAT	CAT I		LOC		CIRCLING	
	DA(H)	RVR/CMV	MDA(H)	RVR/CMV	MDA(H)	VIS
A	220 (200)	750	350 (337)	1000	900	1600
B					460 (447)	
C					470 (457)	2400
D					570 (557)	

MINIMA with Missed APCH climb gradient of 2.5% are not established.

Airspace for the advisory service concerning low level wind shear

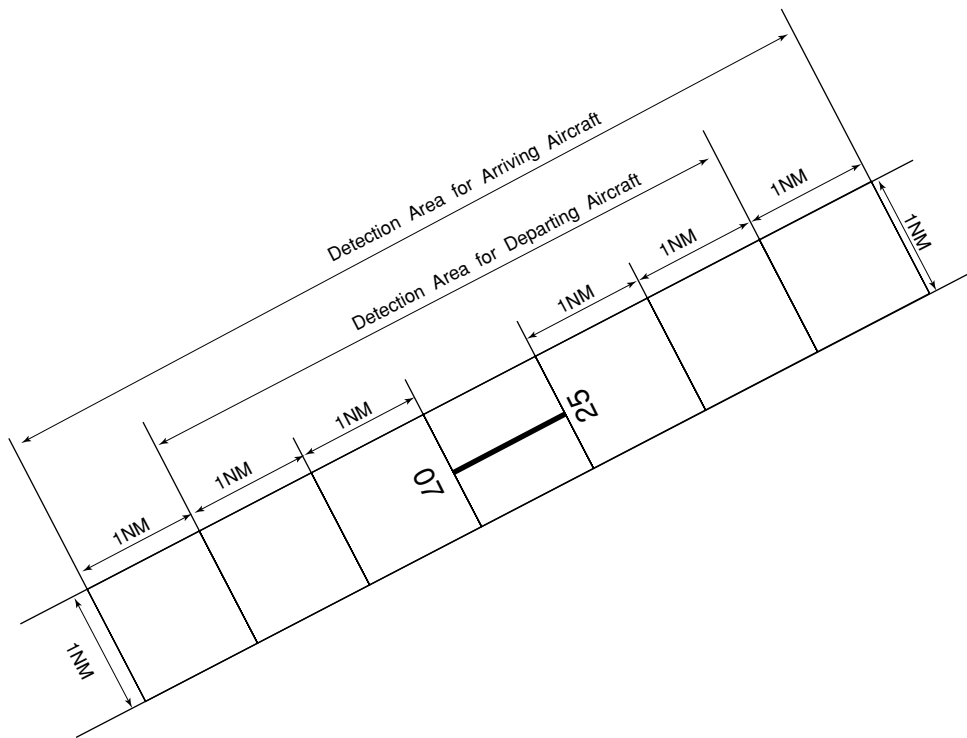

UPPER LIMIT : 1600ft above FIELD ELEV LEVEL

LOWER LIMIT : FIELD ELEV LEVEL

美保進入管制区
Miho Approach Control Area

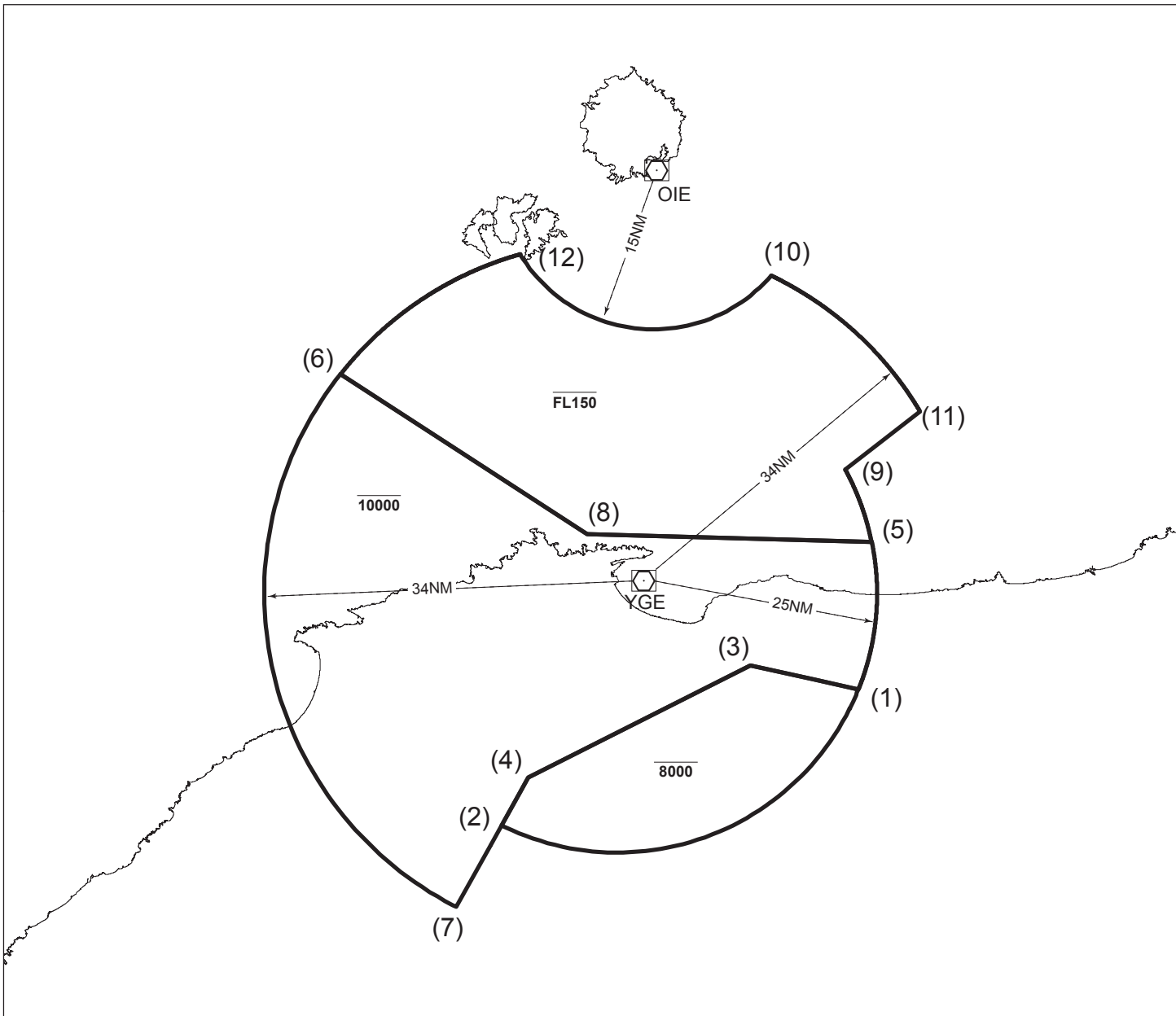

Point list

- | | |
|---------------------|----------------------|
| (1) 352053N1334353E | (7) 345939N1325649E |
| (2) 350734N1330203E | (8) 353546N1331150E |
| (3) 352311N1333110E | (9) 354209N1334218E |
| (4) 351212N1330506E | (10) 360049N1333325E |
| (5) 353507N1334527E | (11) 354745N1335107E |
| (6) 355055N1324226E | (12) 360244N1330336E |

ILS

MIHO AERODROME

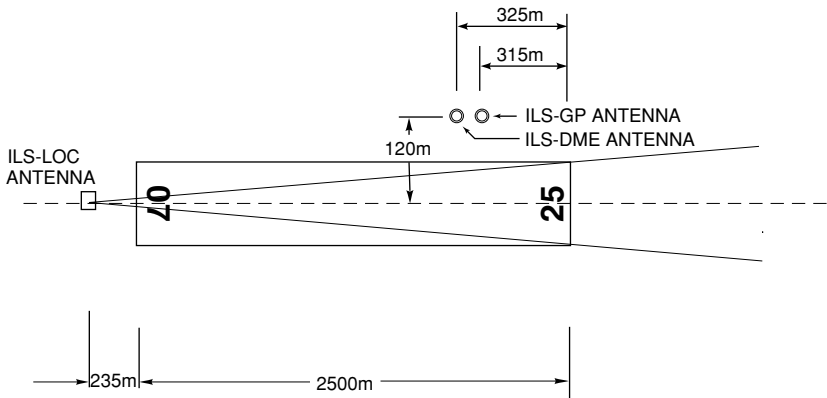

REMARKS :	1. LOC beam BRG (MAG)	251°
	2. HGT of ILS REF datum	16.5m(54ft)
	3. GP Angle	3.0°
	4. ELEV of ILS-DME	9.6m(32ft)