

AD 2 AERODROMES

RJNA AD 2.1 AERODROME LOCATION INDICATOR AND NAME

RJNA - NAGOYA

RJNA AD 2.2 AERODROME GEOGRAPHICAL AND ADMINISTRATIVE DATA

1	ARP coordinates and site at AD	351518N/1365528E 153°/1.42km FM RWY 16 THR
2	Direction and distance from (city)	10km NE FM Nagoya City (Nagoya Station)
3	Elevation/ Reference temperature	46ft / 34.3°C(2000-2004)
4	Geoid undulation at AD ELEV PSN	126ft
5	MAG VAR/ Annual change	7° W(2006) /Annual Change 0.7° W
6	AD Administration, address, telephone, telefax, telex, AFS, e-mail and/or Web-site addresses	Aichi Pref. Public AP Nagoya Airport Administration Office Toyoba, Toyoyamacho, Nishikasugaigun, Aichi Pref. Tel: 0568-29-1785 , Fax: 0568-29-1806 Web: http://www.pref.aichi.jp/0000005859.html
7	Types of traffic permitted(IFR/VFR)	IFR/VFR
8	Remarks	Nil

RJNA AD 2.3 OPERATIONAL HOURS

1	AD Administration	2200 - 1300
2	Customs and immigration	On request Customs: 052-398-4225 Immigration: 052-559-2150
3	Health and sanitation	On request Quarantine(human): 052-661-4131 Quarantine(animal): 052-651-0334, 0569-38-8577 Quarantine(plant): 052-651-0112
4	AIS Briefing Office	Nil
5	ATS Reporting Office(ARO)	Nil
6	MET Briefing Office	Nil
7	ATS	H24 by JSDF-A
8	Fuelling	2100 - 1200
9	Handling	Ask AD Administration
10	Security	Ask AD Administration
11	De-icing	Nil
12	Remarks	Nil

RJNA AD 2.4 HANDLING SERVICES AND FACILITIES

1	Cargo-handling facilities	Nil
2	Fuel/ oil types	Fuel grades : 100, JET A-1 Oil grades : W80,W100, ASTO/500,ASTO/555
3	Fuelling facilities/ capacity	Fuel truck refueling / Ask AD Administration
4	De-icing facilities	Nil
5	Hangar space for visiting aircraft	Nil
6	Repair facilities for visiting aircraft	Nil
7	Remarks	Nil

RJNA AD 2.5 PASSENGER FACILITIES

1	Hotels	Hotels in Nagoya city
2	Restaurants	Around Airport
3	Transportation	Busses and Taxis
4	Medical facilities	Around Airport]
5	Bank and Post Office	Around Airport
6	Tourist Office	Nil
7	Remarks	Nil

RJNA AD 2.6 RESCUE AND FIRE FIGHTING SERVICES

1	AD category for fire fighting	CAT 6
2	Rescue equipment	Chemical fire fighting truck × 2 Emergency medical equipment conveyance truck Lighting power supply truck
3	Capability for removal of disabled aircraft	Nil
4	Remarks	Nil

RJNA AD 2.7 SEASONAL AVAILABILITY-CLEARING

1	Types of clearing equipment	Snow remove equipments:Motor graders
2	Clearance priorities	Nil
3	Remarks	Seasonal availability:All seasons

RJNA AD 2.8 APRONS, TAXIWAYS AND CHECK LOCATIONS DATA

1	Apron surface and strength	<p>All Apron : Surface: asphalt-concrete and cement-concrete Strength:</p> <p>Spot NR1, 2A-2L, 3A-3H, 4A, 4A1, 4A2, 4B, 4C, 4D, 4D1, 4D2, 4E, 4F, 5A-5H, 6A-6H PCN 69/R/C/W/T</p> <p>Spot NR7A-7H, 8A-8I PCN 55/F/D/X/T</p> <p>Spot NR9A-9H, 12A-12H PCN 51/R/A/X/T</p> <p>Spot NR13, 13A, 14, 14A-14E, 15A-15C, other apron taxiways PCN 69/R/C/X/T</p> <p>Compass setting apron PCN 46/F/C/X/U</p>
2	Taxiway width, surface and strength	<p>All TWY Surface: asphalt concrete and cement-concrete</p> <p>TWY WP1: Width: 23m, Strength: PCN 69/R/C/W/T</p> <p>TWY WP2, WP3, WP4, WP5 : Width: 23m, Strength: PCN 83/F/C/X/T</p> <p>TWY W1 : Width: 26.5m, Strength: PCN 83/F/C/X/T</p> <p>TWY W9 : Width: 28.5m, Strength: PCN 83/F/C/X/T</p> <p>TWY W2, W4, W6,W7, W8: Width: 30.0m, Strength: PCN 83/F/C/X/T</p> <p>TWY W3 : Width: 30m, Strength: PCN 97/F/D/W/T</p> <p>TWY W5 : Width: 30m, Strength: PCN 97/F/D/Z/T</p> <p>M1 TWY : Width: 23m, Strength: PCN 54/R/C/X/T</p> <p>M2 TWY : Width: 30m, Strength: PCN 69/R/C/X/T</p> <p>M3 TWY : Width: 23m, Strength: PCN 65/R/C/X/T</p> <p>J TWY : Width: 18m, Strength: PCN 32/F/C/X/T</p>
3	ACL and elevation	Not available
4	VOR checkpoints	Not available
5	INS checkpoints	<p>Spot NR</p> <p>1: 351453.04N 1365531.62E</p> <p>9A: 351510.82N 1365522.27E</p> <p>9B: 351510.30N 1365521.06E</p> <p>9C: 351509.78N 1365519.85E</p> <p>12A: 351515.48N 1365518.50E</p> <p>12B: 351514.34N 1365516.90E</p> <p>12C: 351513.74N 1365515.54E</p> <p>12D: 351512.97N 1365520.90E</p> <p>12E: 351512.45N 1365519.69E</p> <p>12F: 351511.93N 1365518.48E</p> <p>13: 351516.34N 1365517.53E</p> <p>13A: 351516.26N 1365518.21E</p> <p>14: 351516.50N 1365516.93E</p> <p>14A: 351515.88N 1365515.92E</p> <p>14B: 351515.30N 1365514.55E</p> <p>14C: 351519.74N 1365516.08E</p> <p>14D: 351518.92N 1365514.15E</p> <p>14E: 351518.09N 1365512.23E</p> <p>15A: 351522.05N 1365514.62E</p> <p>15B: 351521.22N 1365512.69E</p> <p>15C: 351520.39N 1365510.76E</p>
6	Remarks	Nil

RJNA AD 2.9 SURFACE MOVEMENT GUIDANCE AND CONTROL SYSTEM AND MARKINGS

1	Use of aircraft stand ID signs, TWY guide lines and Visual docking/ parking guidance system of aircraft stands	Nil
2	RWY and TWY markings and LGT	<p>RWY: RWY16/34 (Marking) RWY designation, RWY CL, RWY THR, Aiming point, TDZ, RWY side stripe. (LGT) RCLL, REDL, RTHL, RENL, RTZL(RWY34), WBAR(RWY34), RWY DIST marker LGT</p> <p>TWY: All TWY (Marking) TWY CL, RWY HLDG PSN, TWY side stripe (LGT) TWY edge LGT, TWY CL LGT, Taxiing guidance sign</p>
3	Stop bars	Nil
4	Remarks	<p>(Marking) Overrun area (LGT) Apron flood LGT</p>

RJNA AD 2.10 AERODROME OBSTACLES

■ In Area2 See Obstacle data

■ In Area3 To be developed

RJNA AD 2.11 METEOROLOGICAL INFORMATION PROVIDED

1	Associated MET Office	Aichi Pref.
2	Hours of service MET Office outside hours	Nil
3	Office responsible for TAF preparation Periods of validity	Nil
4	Trend forecast Interval of issuance	Nil
5	Briefing/ consultation provided	Nil
6	Flight documentation Language(s) used	C En
7	Charts and other information available for briefing or consultation	Nil
8	Supplementary equipment available for providing information	Nil
9	ATS units provided with information	TWR
10	Additional information(limitation of service, etc.)	Meteorological charts (S ₆ , U ₈₅ , U ₇ , U ₅ , U ₃ , P _S , P ₅ , P _{SW} , U ₂ /T _r , C) are displayed, while briefing is not provided.

Airspace for the advisory service concerning low level wind shear

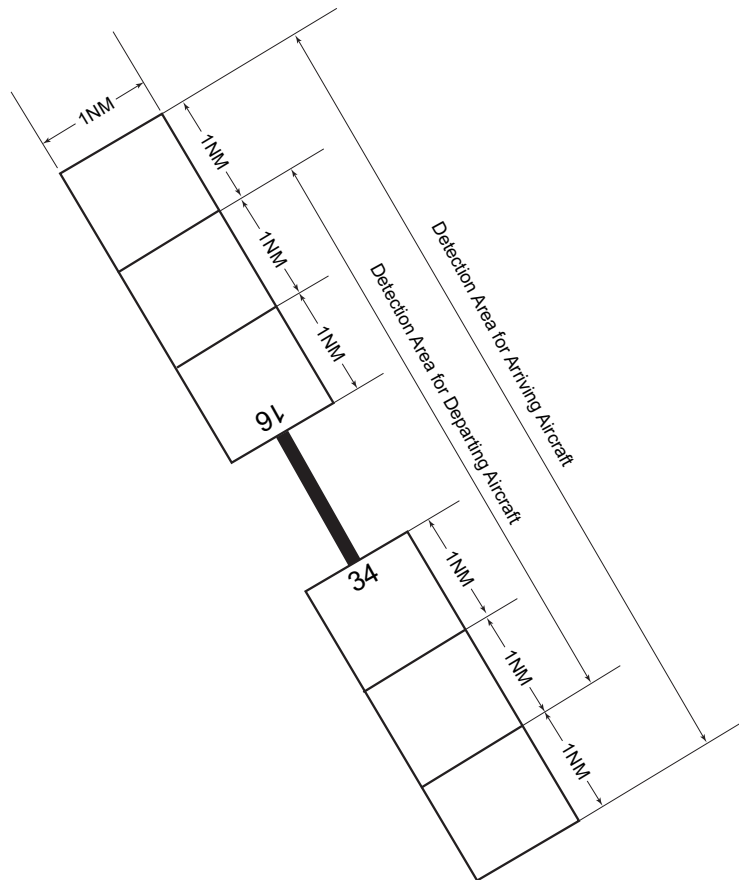

UPPER LIMIT : 1600ft above FIELD ELEV LEVEL
LOWER LIMIT : FIELD ELEV LEVEL

RJNA AD 2.12 RUNWAY PHYSICAL CHARACTERISTICS

Designations RWY NR	TRUE BRG	Dimensions of RWY(M)	Strength(PCN) and surface of RWY	THR coordinates THR geoid undulation	THR elevation and highest elevation of TDZ of precision APP RWY
1	2	3	4	5	6
16	152.42°	2740x45	PCN63/F/B/X/T Asphalt Concrete	351559.16N 1365502.69E 125ft	THR ELEV:52ft TDZ ELEV:52ft
34	332.42°	2740x45	PCN63/F/B/X/T Asphalt Concrete	351440.36N 1365552.86E 126ft	THR ELEV:50.0ft TDZ ELEV:52ft

Slope of RWY	Strip Dimensions(M)	RESA(Overrun) Dimensions(M)	Remarks
7	10	11	14
See Below Chart	2860x300	240x(MNM:197 MAX:341)*	RWY grooving : 2740m x 30m Overrun barrier(type net) 75m outside from THR, Arresting gear 17m outside from THR.
See Below Chart	2860x300	240x(MNM:200 MAX:300)* *For detail, ask airport administrator	RWY grooving : 2740m x 30m Overrun barrier(type net) 42m outside from THR, Arresting gear at THR

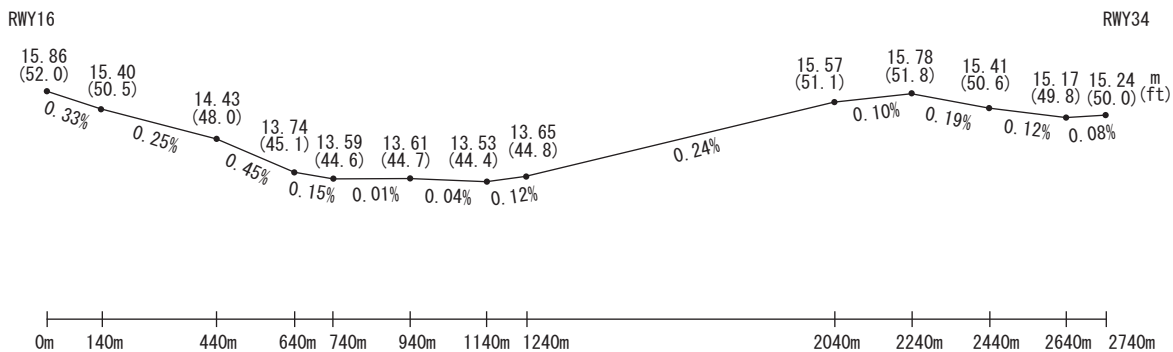

RJNA AD 2.13 DECLARED DISTANCES

RWY Designator	TORA (m)	TODA (m)	ASDA (m)	LDA (m)	Remarks
1	2	3	4	5	6
16	2740	2740	2740	2740	Nil
34	2740	2740	2740	2740	Nil

RJNA AD 2.14 APPROACH AND RUNWAY LIGHTING

RWY Designator	APCH LGT type LEN INTST	RTHL Color WBAR	PAPI (VASIS) Angle DIST FM THR MEHT	RTZL LEN	RCLL LEN Spacing Color INTST	REDL LEN Spacing Color INTST	RENL Color WBAR	STWL LEN Color
1	2	3	4	5	6	7	8	9
16	PALS 480m LIH	Green -	PAPI 3.0°/LEFT 437m 64ft	-	2,740m 30m Coded color (White/Red) LIH	2,740m 60m Coded color (White/Yellow) LIH	Red	Nil (*1)
34	PALS (CAT I) 450m LIH	Green Green	PAPI 3.0°/LEFT 419m 67.3ft	900m	2,740m 30m Coded color (White/Red) LIH	2,740m 60m Coded color (White/Yellow) LIH	Red	Nil (*1)
Remarks								
10								
Overrun area edge LGT(LEN:60m Color:Red)(*1)								

RJNA AD 2.15 OTHER LIGHTING, SECONDARY POWER SUPPLY

1	ABN/IBN location, characteristics and hours of operation	ABN: 351508N/1365516E, White/Green EV4.3sec, HO
2	LDI location and LGT Anemometer location and LGT	LDI : Nil Anemometer : RWY16 : 350m FM RWY16 THR, LGTD RWY34 : 390m FM RWY34 THR, LGTD
3	TWY edge and centerline lighting	TWY edge LGT: Blue TWY CL LGT: ALTN Green/Yellow FM RWY leaving report point, other green
4	Secondary power supply/ switch-over time	Within 1 sec: REDL, RENL, RTHL, WBAR, RCLL and Overrun area edge LGT Within 15 sec: Other lights
6	Remarks	WDI LGT

RJNA AD 2.16 HELICOPTER LANDING AREA

Nil

RJNA AD 2.17 ATS AIRSPACE

Designation and lateral limits		Vertical limits (ft)	Airspace classification	ATS unit call sign Language	Remarks
1		2	3	4	6
NAGOYA CTR	Area defined as follows. (1) Area within a radius of 5NM of NAGOYA ARP (3515N/13655E) (2) Area within a line connecting 3515N13659E, 3511N13701E, 3509N13657E, 3513N13654E and 3515N13659E in consecutive order.	3000	D	NAGOYA TWR En	
NAGOYA PCA	1. The airspace bounded by the lines connecting the following points. (1) 351103N/1370057E, (2) 350913N/1365637E, (3) 350633N/1365818E, (4) 350824N/1370238E thence to point(1).	4000 800	C	CENTRAIR APP CENTRAIR RADAR CENTRAIR DEP EN	
	2. The airspace bounded by the lines connecting the following points. (4) 350824N/1370238E, (3) 350633N/1365818E, (5) 350338N/1370008E, (6) 350531N/1370426E thence to point(4). The line connecting point(5) to point(6) is the minor arc with a radius of 13NM from Nagoya VORTAC(KCC).	5000 1300			
CHUBU ACA	See RJGG AD2.17		E	CENTRAIR APP/DEP/ RADAR En	
CHUBU TCA	See RJGG AD2.17		E	CENTRAIR TCA En	

名古屋特別管制区
Nagoya Positive Control Area

NAME	LATERAL LIMITS	UPPER LIMIT (AMSL)	UNIT PROVIDING SERVICE	REMARKS
		LOWER LIMIT (AMSL) M(ft)		
1	2	3	4	5
名古屋 NAGOYA	下記に示される区域 The area shown below		Primary Centrair APP 121.05 119.175 228.4 245.3 Centrair Radar 125.55 Secondary Nagoya TWR 118.7 236.8 122.7 305.7	当該空域を飛行しようとする航空機は、Centrairアプローチ（Centrairレーダー）又は名古屋タワーに連絡し、現在位置、高度及び意図を通報し指示を受けること。 Pilot of aircraft operating in this area shall contact Centrair APP(RADAR) or Nagoya TWR, for ATC instructions giving informations on aircraft identification, position, altitude and pilot's intention.

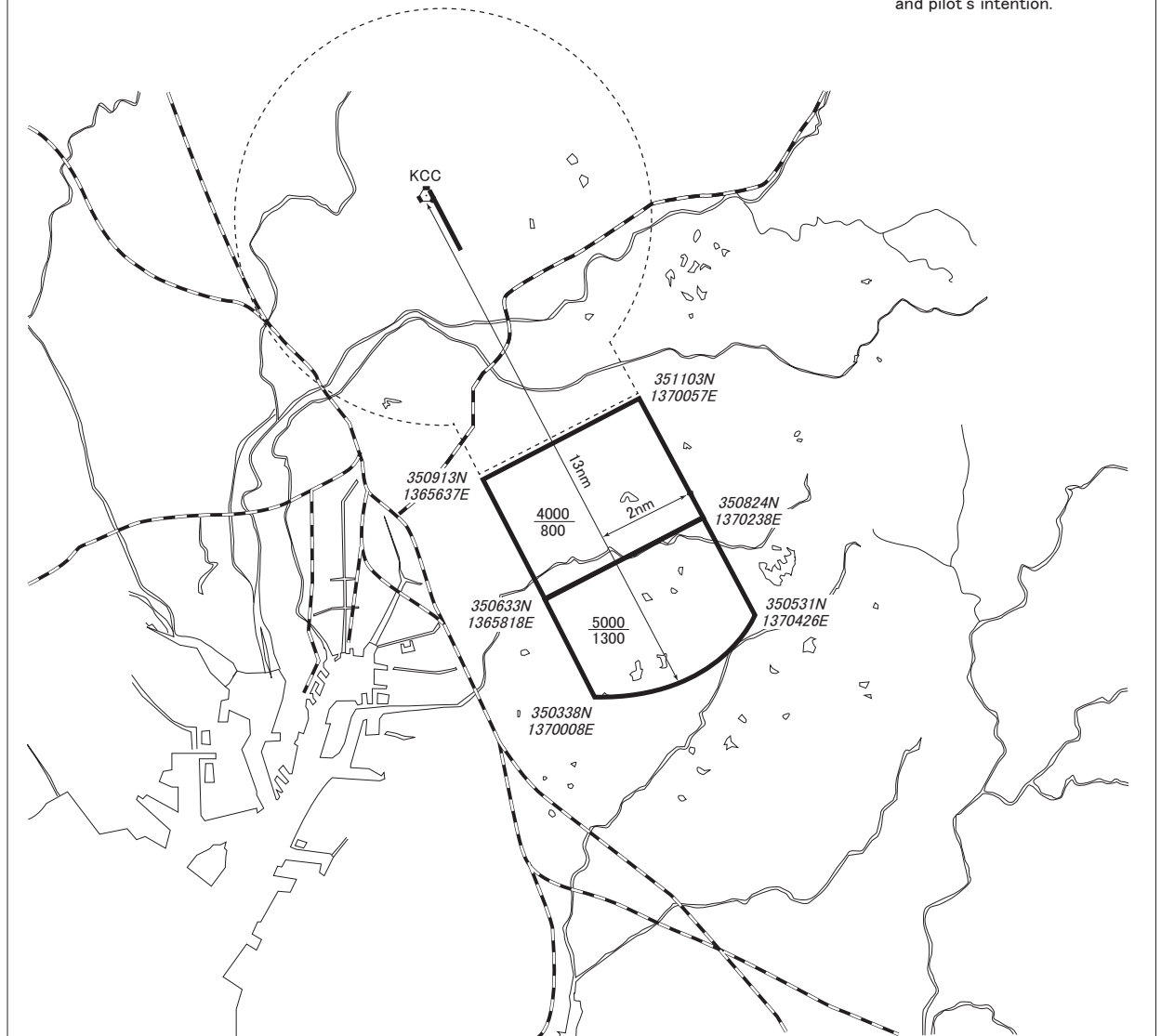

RJNA AD 2.18 ATS COMMUNICATION FACILITIES

Service designation	Call sign	Frequency	Hours of operation	Remarks
1	2	3	4	5
APP	Centrair Approach	119.175 MHz (1) 245.3 MHz (1) 121.05 MHz 228.4 MHz 121.5 MHz (E) 243.0 MHz (E)	H24	(1) Primary
RADAR	Centrair Radar	121.225 MHz 227.2 MHz 125.55 MHz 121.5 MHz (E) 243.0 MHz (E)	H24	
DEP	Centrair Departure	121.225 MHz 227.2 MHz 119.175 MHz 245.3 MHz 121.5 MHz (E) 243.0 MHz (E)	H24	
TCA	Centrair TCA	119.25 MHz 321.2 MHz 121.175 MHz 318.0 MHz	2330 - 1100	
TWR	Nagoya Tower	236.8 MHz 305.7 MHz 118.7 MHz 122.7 MHz 247.0 MHz (1) 138.05 MHz (1) 123.1 MHz (1) 243.0 MHz (E) 121.5 MHz (E)	H24	(1) For rescue only
GND	Nagoya Ground	275.7 MHz 121.7 MHz	H24	
DLVRY	Nagoya Delivery	258.9 MHz 121.75 MHz	H24	
GCA-ASR -PAR	Nagoya GCA	270.8 MHz 335.6 MHz 239.3 MHz 134.1 MHz 119.9 MHz 120.3 MHz 243.0 MHz(E) 121.5 MHz(E)	H24	See AD2.22 "FLIGHT PROCEDURES"

RJNA AD 2.19 RADIO NAVIGATION AND LANDING AIDS

Type of aid (VOR declination)	ID	Frequency	Hours of operation	Position of transmitting antenna coordinates	Elevation of DME transmitting antenna	Remarks
1	2	3	4	5	6	7
VOR (8°W / 2017)	KCC	114.2MHz	H24	351554.96N 1365453.73E		VOR Unusable: 200°-210° beyond 35nm BLW 5000ft. 260°-270° beyond 30nm BLW 7000ft. 320°-340° beyond 20nm BLW 8000ft.
TACAN	KCC	1176MHz (CH-89X)	H24	351555.75N 1365452.23E	83ft	TACAN DME unusable: 200°-210° beyond 35nm BLW 5000ft. TACAN AZM unusable: 160°-180° beyond 35nm BLW 5000ft. 180°-200° beyond 30nm BLW 5000ft. 200°-210° beyond 25nm BLW 5000ft. 260°-270° beyond 35nm BLW 7000ft.
ILS-LOC34	IKC	108.9MHz	2200-1300	351611.06N 1365455.11E		BRG (MAG) 341° 414m away FM RWY16 THR
ILS-GP34		329.3MHz	2200-1300	351448.37N 1365542.42E		GP angle 3.0° HGT of ILS Ref datum 55ft 341m inside FM RWY34 THR 120m SW of RCL
ILS-DME34	IKC	987MHz (CH-26X)	2200-1300	351448.41N 1365542.23E	63.8ft	344m inside FM RWY34 THR 124m SW of RCL
MSAS		1575.42MHz	H24			Transmitting antennas are satellite based

NAGOYA AIRPORT

ILS for RWY 34

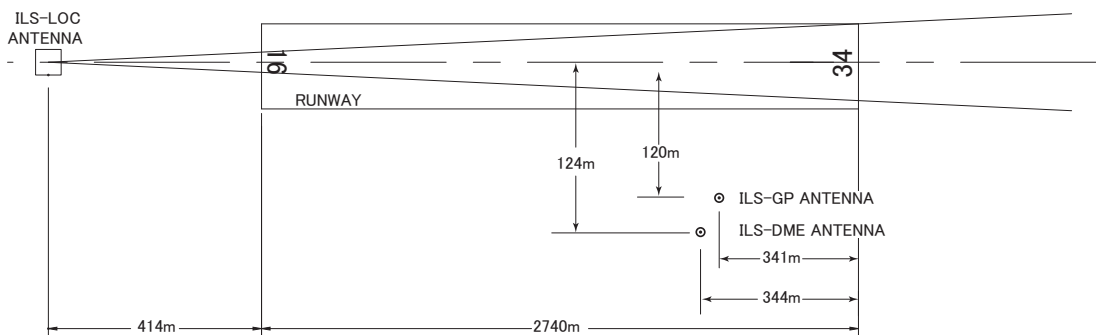

- REMARKS:
- 1. LOC beam BRG(MAG) 341°
 - 2. HGT of ILS REF datum 16.8m (55ft)
 - 3. GP Angle 3.0°
 - 4. ELEV of ILS-DME 19.5m (63.8ft)

RJNA AD 2.20 LOCAL TRAFFIC REGULATIONS

1. Airport regulations

1.1 空港の使用について、航空機の運航者はあらかじめ愛知県に届け出ること。	1.1 On use of NAGOYA airport , aircraft operator is required to notify Aichi Pref in advance.
1.2 訓練飛行を行うときは、愛知県の承認を得ること。	1.2 Training flight is subject to the approval of Aichi Pref.

2. Taxiing to and from stands

Nil

3. Parking area for small aircraft(General aviation)

Nil

4. Parking area for helicopters

Nil

5. Apron - taxiing during winter conditions

Nil

6. Taxiing - limitations

6.1 誘導路交差点の翼端クリアランス

(AD1.1.6.8 参照)

誘導路上の停止位置に待機中の航空機と後方の誘導路を走行する航空機の翼端クリアランスは以下のとおりである。

(1) When B773 holding at the stop marking on TWY W2 or W8

Wing Span (WS) of aircraft taxiing on WP1 - Apron TWY or WP3 - WP4	WS ≤ 15.2m	15.2m < WS ≤ 32.2m	WS > 32.2m
Wing tip clearance	*A	*B	*C

(2) When A333 holding at the stop marking on TWY W7

Wing Span (WS) of aircraft taxiing on WP2 - WP3	WS ≤ 12.9m	WS > 12.9m
Wing tip clearance	*B	*C

Legend:

*A : wing tip clearance ≥ 15m

*B : 6.5m ≤ wing tip clearance < 15m

*C : wing tip clearance < 6.5m

6.2 B773 のための誘導路運用ガイダンス

B773 の操縦士は、誘導路 W2、W4、W5、W6、W7、W8 のコーナーには特に注意を払うこと。

6.2 TWY operational guidance for B773

The pilots of B773 are required to pay special attention at the corner section TWY W2, W4, W5, W6, W7 and W8.

7. School and training flights - technical test flights - use of runways

Nil

8. Helicopter traffic - limitation

Nil

9. Removal of disabled aircraft from runways

Nil

RJNA AD 2.21 NOISE ABATEMENT PROCEDURES

<p>1. 騒音軽減運航方式</p> <p>すべてのジェット機に対して、空港周辺における航空機騒音軽減のため、運航の安全に支障のない範囲で、以下の方式が適用される。ただし、これらの方式によることができない航空機は実効的にこれらと同等と認められる代替方式を実施するものとする。</p> <p>(1) 離陸について (滑走路 16/34) 急上昇方式</p> <p>(2) 着陸について (滑走路 16/34) ディレイド・フラップ進入方式及び低フラップ角着陸方式</p> <p>(3) リバース・スラストについて なし</p> <p>2. 優先滑走路方式 なし</p> <p>3. 優先飛行経路</p> <p>すべてのジェット機に対して、航行の安全確保及び飛行の目的に支障がない範囲において適用される。</p> <p>(1) 滑走路 34 から離陸する場合 名古屋 VORTAC から 2 海里の地点を通過するまで直線飛行する。</p> <p>(2) 滑走路 16 から離陸する場合 名古屋 VORTAC から 3 海里の地点を通過するまで直線飛行する。</p> <p style="text-align: right;">AD 1.1.6.5 参照</p>	<p>1. Noise Abatement Operating Procedures</p> <p>For all jet aircraft, in order to reduce aircraft noise in the vicinity of the airport, the following procedures shall be applied unless compliance of the procedures adversely affects the safety of aircraft operations. In case that the aircraft is unable to take these procedures, pilots should execute alternative procedures which are considered to be practically equivalent.</p> <p>(1) For take-off from RWY 16/34 Steepest Climb Procedure</p> <p>(2) For landing to RWY 16/34 Delayed Flap Approach Procedure and Reduced Flap Setting Procedure</p> <p>(3) Reverse Thrust Nil</p> <p>2. Preferential Runways Procedures Nil</p> <p>3. Noise Preferential Routes</p> <p>For all jet aircraft, the following noise preferential routes are adopted, as long as flight safety is not jeopardized or purpose of flight is not hindered.</p> <p>(1) For take-off from RWY 34 Pilots are requested to strictly follow extended runway centerline until passing 2NM from Nagoya VORTAC.</p> <p>(2) For take-off to RWY 16 Pilots are requested to strictly follow extended runway centerline until passing 3NM from Nagoya VORTAC.</p> <p style="text-align: right;">See : AD1.1.6.5</p>
---	--

RJNA AD 2.22 FLIGHT PROCEDURES

1. TAKE OFF MINIMA

	RWY	ACFT CAT	REDL & RCLL		REDL or RCLL or RCL Marking		NIL (DAYTIME ONLY)	
			RVR	VIS	RVR	VIS	RVR	VIS
Multi-Engine ACFT with TKOF ALTN AP FILED	16	A, B, C, D	400m	400m	400m	400m	-	500m
	34							
OTHER	16	A, B, C, D	AVBL LDG MINIMA					
	34							

2. WX MINIMA CONCERNING PAR/ASR APCH PROCEDURE

PAR RWY 16

MINIMA	THR ELEV:52		AD ELEV: 46	
	PAR		CIRCLING	
	DA(H)	RVR/CMV	MDA(H)	VIS
A	252(200)	750	680(634)	1600
B				2400
C			860(814)	
D				

PAR RWY 34

MINIMA	THR ELEV:50		AD ELEV: 46	
	PAR		CIRCLING	
	DA(H)	RVR/CMV	MDA(H)	VIS
A	252(202)	700	680(634)	1600
B				2400
C			860(814)	
D				

ASR RWY 16

MINIMA	THR ELEV:52		AD ELEV: 46	
			CIRCLING	
	MDA(H)	RVR/CMV	MDA(H)	VIS
A	680(634)	1400	680(634)	1600
B		1500		
C		1600	860(814)	2400
D		1800		3200

ASR RWY 34

MINIMA	THR ELEV:50		AD ELEV: 46	
			CIRCLING	
	MDA(H)	RVR/CMV	MDA(H)	VIS
A	540(494)	1400	680(634)	1600
B		1500		
C		1600	860(814)	2400
D		1800		3200

3. Lost communication procedures for arrival aircraft under radar navigational guidance

If radio communications with Centrair Approach/Radar or NAGOYA GCA are lost for 1 minute, or 5 seconds(PAR)/15 seconds(ASR) on final approach, squawk Mode A/3 Code 7600 and;

- (I)
1. Contact Nagoya Tower.
 2. If unable, proceed in accordance with Visual Flight Rules.
 3. If unable,
 - a) Proceed to Nagoya VORTAC at last assigned altitude or 3,000FT whichever is higher and execute Instrument Approach.
 - b) Proceed to SHATI via Nagoya VORTAC at last assigned altitude or 5,000FT whichever is higher and execute TACAN A Approach.
- (II) Procedures other than above will be issued when situation required.

4. Automated Radar Terminal System(ARTS)

セントレアアプローチの指示のもとに、中部進入管制区を飛行する航空機は、モード A/3 の二次レーダー個別コード及びモード C による応答を指示される。

二次レーダー個別コードを搭載していない航空機が当該コードによる応答を指示された場合は、管制官に対し、その旨通報すること。

Aircraft flying under control of "Centrair Approach" in the Chubu approach control area will be instructed to reply with discrete code on Mode A/3 and Mode C.

If an aircraft with non-discrete code capability be instructed to reply with the discrete code, it shall report a controller accordingly.

5. PAR 進入 滑走路 16 / 34
グライドパス 3.0°

5. PAR RWY16/34
Glide path 3.0°

6. 場周経路を飛行する際の高度

場周経路を飛行する際の高度は以下のとおり。

- (1) 固定翼航空機
- 1) ジェット 2,000 フィート
 - 2) プロペラ

単発機	1,000 フィート
多発機	1,200 フィート (4 発機を除く。)
4 発機	1,500 フィート
 - (2) 回転翼航空機 800 フィート

6. Altitude at Traffic Pattern as follows

Traffic Pattern Altitude as follows.

- (1) Fixed aircraft
- a) Jet 2,000ft
 - b) Propeller

Single engine	1,000ft
Multi engine	1,200ft(except 4 engines)
4 engines	1,500ft
 - (2) Rotor craft 800ft

RJNA AD 2.23 ADDITIONAL INFORMATION

1. Extensive military jet aircraft and military rescue helicopter activities in NAGOYA and GIFU CTZ.
1. 名古屋及び岐阜管制圏内で、軍用ジェット機及び軍用救難ヘリコプターが大規模に活動している。
2. Building(See below chart) 建築物

建築物 / Building

建築物

1. 位置 : $35^{\circ}12'58''/136^{\circ}54'47''$ (名古屋空港標点から南4.4km)
- See LDG CHART
2. 高さ : 552FT (168m) MSL
525FT (160m) AGL
3. 備考 : 中光度及び低光度航空障害灯が下図のとおり設置されている。

Building

1. Position : $35^{\circ}12'58''/136^{\circ}54'47''$ (4.4km S from NAGOYA ARP)
- See LDG CHART
2. Height : 552FT (168m) MSL
525FT (160m) AGL
3. Remarks : Medium-intensity and low-intensity obstacle lights are installed on this tower as shown in below figure.

- ☆ 中光度航空障害灯
Medium-intensity obstacle lights
- ★ 低光度航空障害灯
Low-intensity obstacle lights

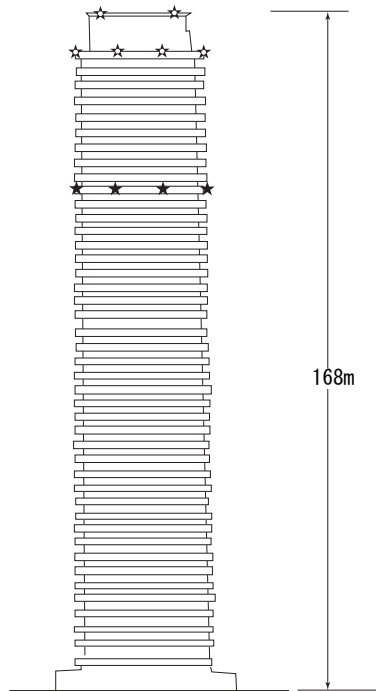

RJNA AD 2.24 CHARTS RELATED TO AN AERODROME

Aerodrome/Heliport Chart
Aircraft Parking/Docking Chart
Standard Departure Chart - Instrument (IBUKI)
Standard Departure Chart - Instrument (HOUBA)
Standard Departure Chart - Instrument (MORIZ)
Standard Departure Chart - Instrument (NAGOYA)
Standard Departure Chart - Instrument (TALMI)
Standard Departure Chart - Instrument (TRANSITION-RNAV)
Standard Arrival Chart - Instrument (EXPOH)

Standard Arrival Chart - Instrument (ORIBE EAST/SOUTH, SHINO-RNAV)
Instrument Approach Chart (ILS Z or LOC Z RWY34)
Instrument Approach Chart (ILS Y or LOC Y RWY34)
Instrument Approach Chart (VOR RWY34)
Instrument Approach Chart (VOR A)
Instrument Approach Chart (TACAN A)
Instrument Approach Chart (RNAV(GNSS) RWY16)
Other Chart (Visual REP)
Other Chart (LDG CHART)
Other Chart (MVA CHART)

INTENTIONALLY LEFT BLANK

RJNA / NAGOYA

AD CHART

CHANGE: CEILOMETER, RVR relocated. WIND SPEED METER added.

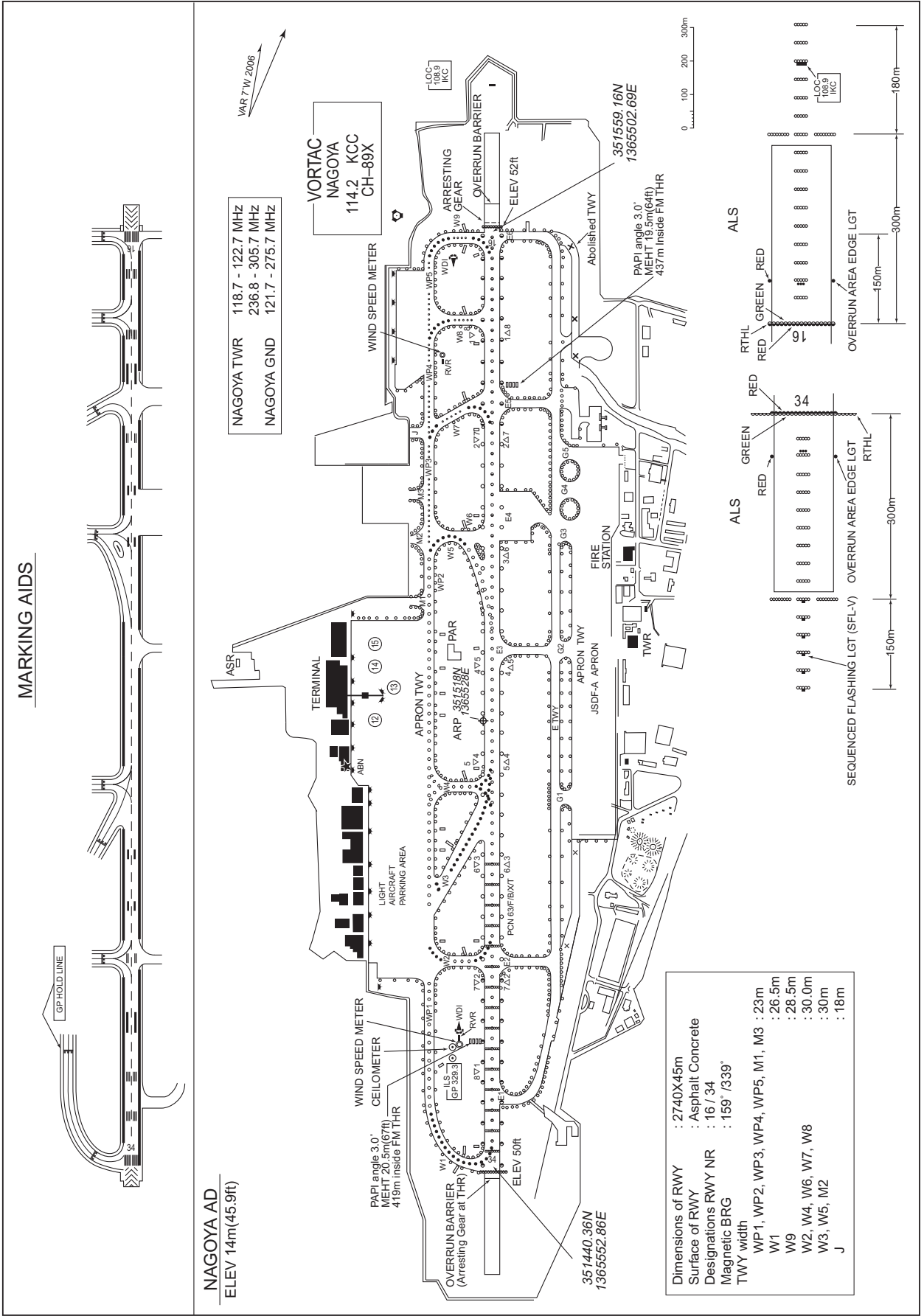

STANDARD ARRIVAL CHART -INSTRUMENT

RJNA / NAGOYA

RNAV STAR

ORIBE EAST ARRIVAL
SHINO ARRIVAL

RNAV1

Note 1) DME/DME/IRU or GNSS required.
2) RADAR service required.

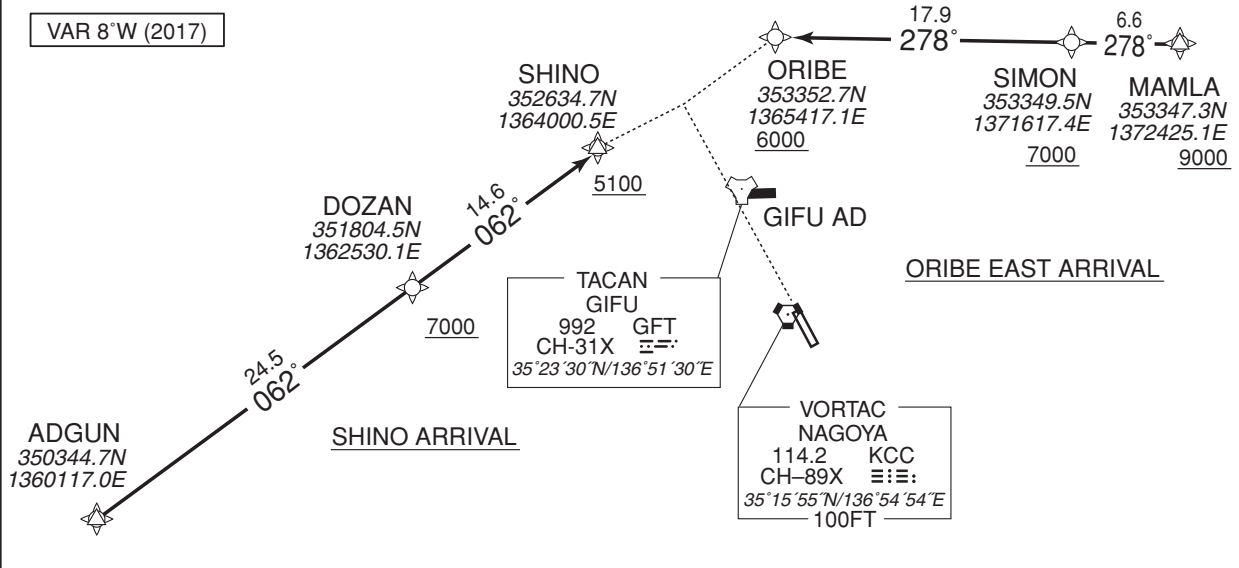

ORIBE EAST ARRIVAL

From MAMLA, at or above 9000FT, to SIMON at or above 7000FT, to ORIBE at or above 6000FT.

Critical DME	GFT : 5.0NM to SIMON - 4.0NM to ORIBE YME : 4.0NM to ORIBE - ORIBE
DME GAP	-
Inappropriate Nav aids	See AD1.1.6.10.3. Inappropriate NAVAIDS for RNAV1

Serial Number	Path Descriptor	Waypoint Identifier	Fly Over	Course °M(°T)	Magnetic Variation	Distance (NM)	Turn Direction	Altitude (FT)	Speed (KIAS)	Vertical Angle	Navigation Specification
001	IF	MAMLA	-	-	-7.7	-	-	+9000	-	-	RNAV1
002	TF	SIMON	-	278 (270.4)	-7.7	6.6	-	+7000	-	-	RNAV1
003	TF	ORIBE	-	278 (270.3)	-7.7	17.9	-	+6000	-	-	RNAV1

SHINO ARRIVAL

From ADGUN, to DOZAN at or above 7000FT, to SHINO at or above 5100FT.

Critical DME	-
DME GAP	-
Inappropriate Nav aids	See AD1.1.6.10.3. Inappropriate NAVAIDS for RNAV1

Serial Number	Path Descriptor	Waypoint Identifier	Fly Over	Course °M(°T)	Magnetic Variation	Distance (NM)	Turn Direction	Altitude (FT)	Speed (KIAS)	Vertical Angle	Navigation Specification
001	IF	ADGUN	-	-	-7.7	-	-	-	-	-	RNAV1
002	TF	DOZAN	-	062 (054.0)	-7.7	24.5	-	+7000	-	-	RNAV1
003	TF	SHINO	-	062 (054.2)	-7.7	14.6	-	+5100	-	-	RNAV1

CHANGE : GIFU TACAN(GFT)

STANDARD ARRIVAL CHART -INSTRUMENT

RJNA / NAGOYA

RNAV STAR

ORIBE SOUTH ARRIVAL

RNAV1

Note 1) DME/DME/IRU or GNSS required.
2) RADAR service required.

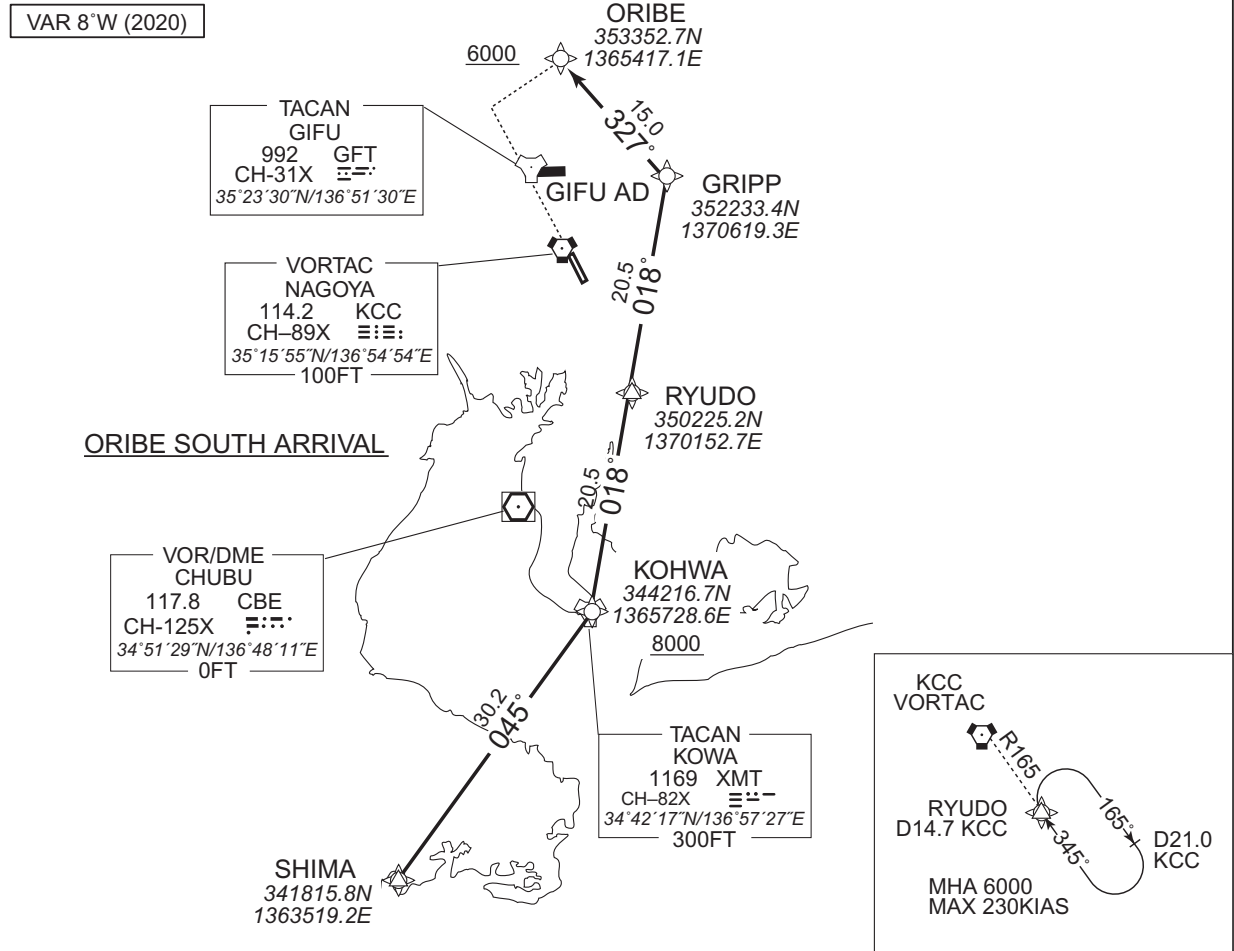

ORIBE SOUTH ARRIVAL

From SHIMA, to KOHWA at or above 8000FT, to RYUDO, to GRIPP, to ORIBE at or above 6000FT.

Critical DME	GFT : 11.0NM to ORIBE - 6.0NM to ORIBE YME : 2.0NM to ORIBE - ORIBE
DME GAP	3.0NM to ORIBE - 2.0NM to ORIBE
Inappropriate Nav aids	See AD1.1.6.10.3. Inappropriate NAVAIDS for RNAV1

CHANGE : VAR. Critical DME. DME GAP.

Serial Number	Path Descriptor	Waypoint Identifier	Fly Over	Course °M(°T)	Magnetic Variation	Distance (NM)	Turn Direction	Altitude (FT)	Speed (KIAS)	Vertical Angle	Navigation Specification
001	IF	SHIMA	-	-	-7.9	-	-	-	-	-	RNAV1
002	TF	KOHWA	-	045 (037.1)	-7.9	30.2	-	+8000	-	-	RNAV1
003	TF	RYUDO	-	018 (010.1)	-7.9	20.5	-	-	-	-	RNAV1
004	TF	GRIPP	-	018 (010.2)	-7.9	20.5	-	-	-	-	RNAV1
005	TF	ORIBE	-	327 (319.2)	-7.9	15.0	-	+6000	-	-	RNAV1

INSTRUMENT APPROACH CHART

RJNA / NAGOYA

ILS Z or LOC Z RWY34

CENTRAIR APP 121.05 – 119.175 228.4 – 245.3	ILS – LOC 108.9 IKC ≡≡≡ ILS–GP 329.3 ILS–DME CH–26X	NAGOYA TOWER 118.7 - 122.7 236.8 - 305.7	RADAR AVBL CALL CENTRAIR RADAR
---	--	--	-----------------------------------

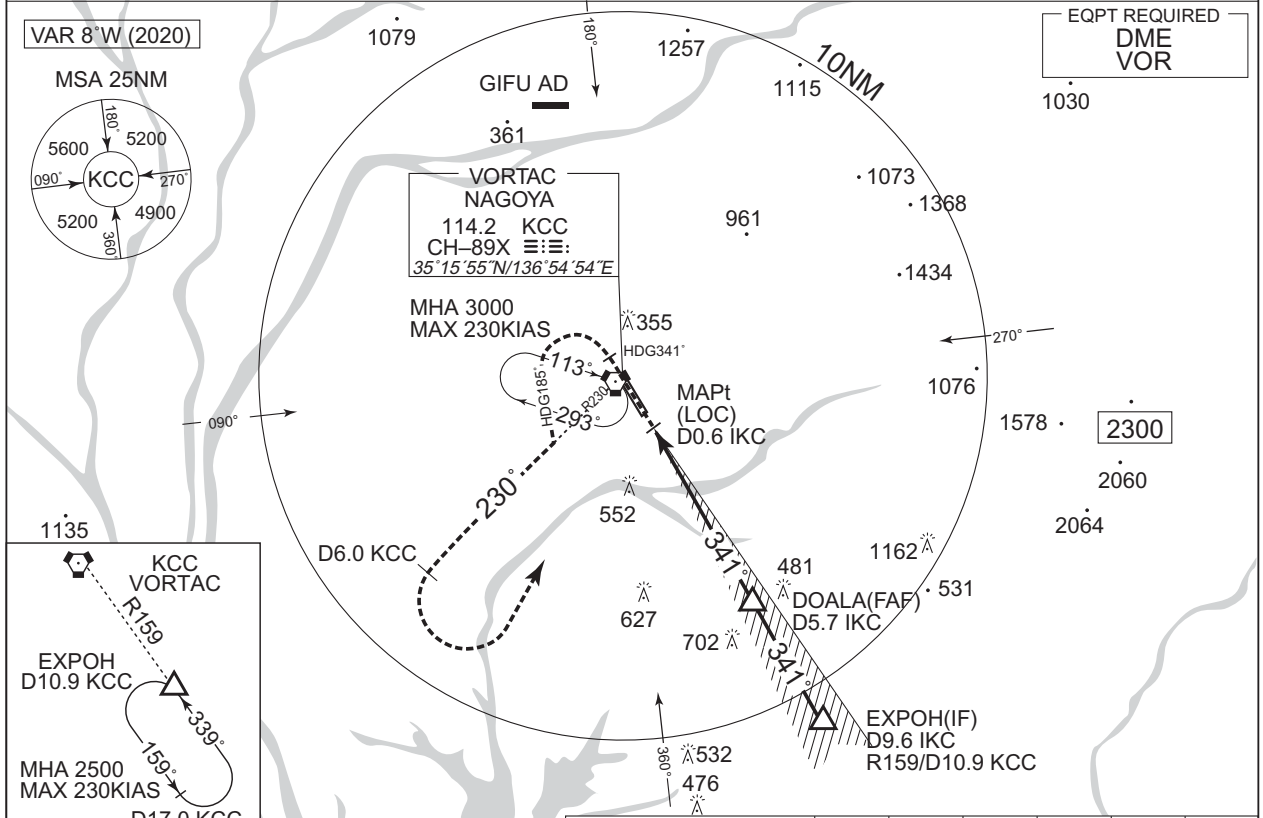

NM to IKC	MAPt	2	3	4	5	FAF
ALT (3.0° APCH Path)	-	677	996	1314	1633	1867

CHANGE : VAR. Course on Final. HDG after MAPt. DME to IKC.

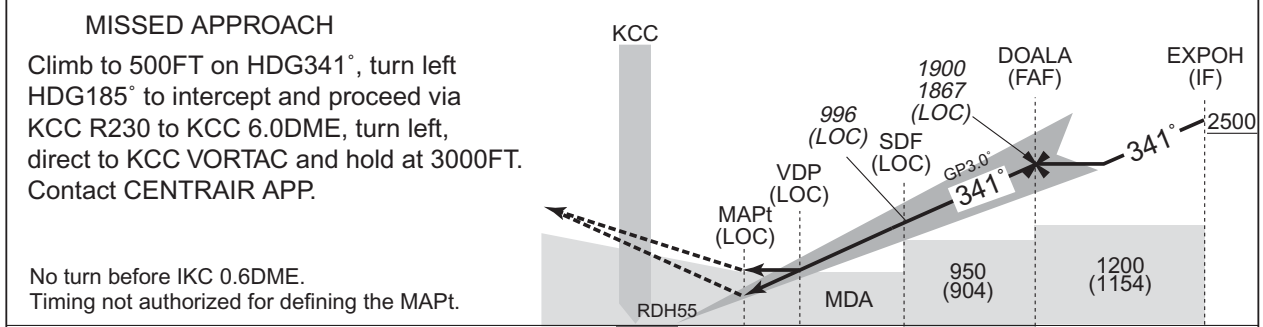

DME to IKC	0.2	0.6	1.5	3.0	5.7	9.6
NM to THR	0	0.5	1.3	2.8	5.6	9.4

Missed APCH climb gradient MNM 4.0%

MINIMA		THR elev. 50		AD elev. 46		
CAT	CAT I	LOC		CIRCLING		
	DA(H)	RVR/CMV	MDA(H)	RVR/CMV	MDA(H) VIS	
A	250 (200)	700	490 (444)	1200	650 (604)	1600
B				1300		
C				1400	850 (804)	2400
D				1600		

MINIMA with Missed APCH climb gradient of 2.5% are not established.

INSTRUMENT APPROACH CHART

RJNA / NAGOYA

ILS Y or LOC Y RWY34

CENTRAIR APP 121.05 – 119.175 228.4 – 245.3	ILS – LOC 108.9 IKC ≡≡≡ ILS-GP 329.3 ILS-DME CH-26X	NAGOYA TOWER 118.7 - 122.7 236.8 - 305.7	RADAR AVBL CALL CENTRAIR RADAR
---	--	--	-----------------------------------

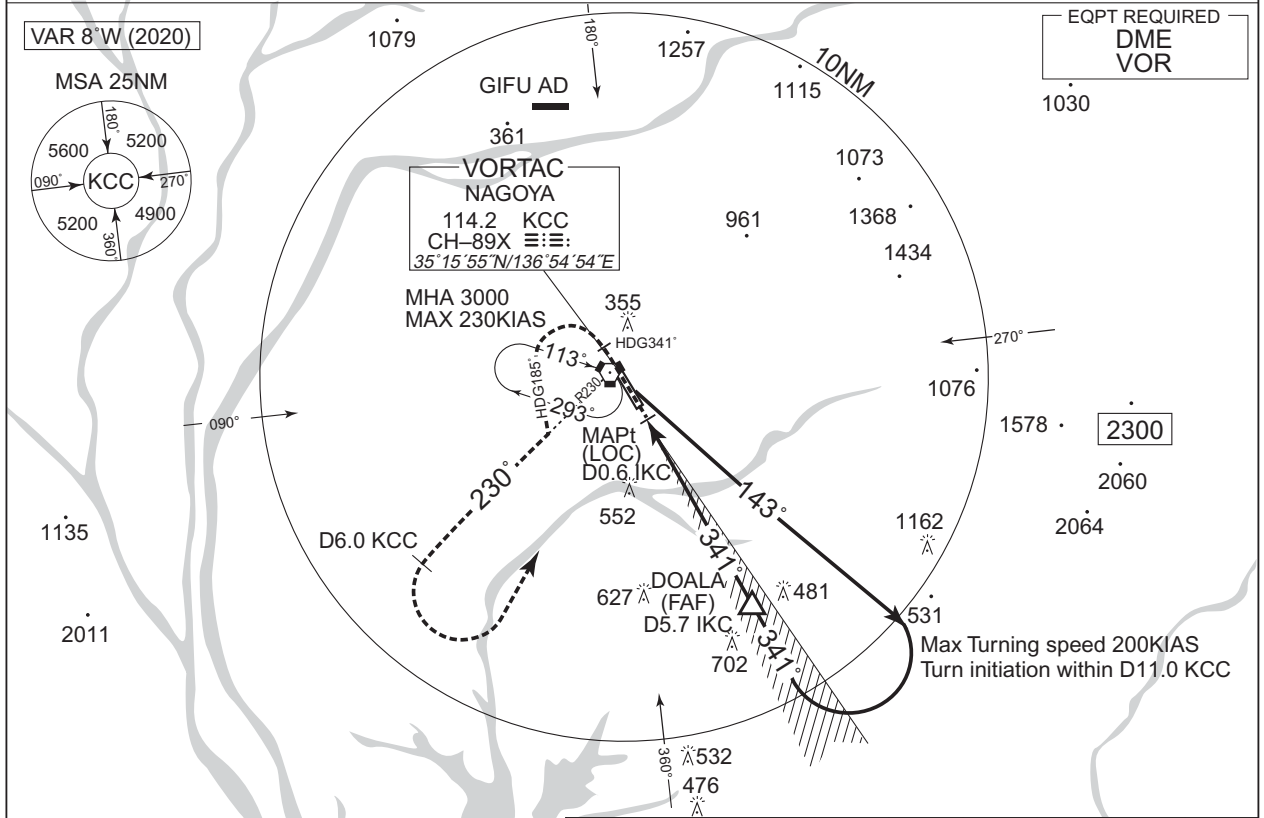

DOALA(FAF) : 350944.64N/1365900.87E	NM to IKC	MAPt	2	3	4	5	FAF
	ALT (3.0° APCH Path)	-	677	996	1314	1633	1867

CHANGE : VAR. Course on Final. HDG after MAPt. DME to IKC.

MISSED APPROACH

Climb to 500FT on HDG341°, turn left HDG185° to intercept and proceed via KCC R230 to KCC 6.0DME, turn left, direct to KCC VORTAC and hold at 3000FT. Contact CENTRAIR APP.

No turn before IKC 0.6DME.
Timing not authorized for defining the MAPt.

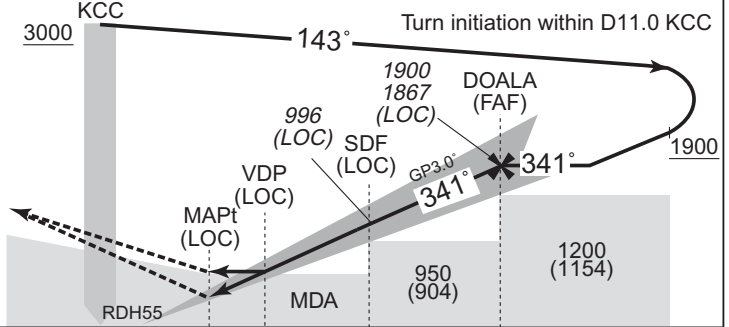

DME to IKC	0.2	0.6	1.5	3.0	5.7
NM to THR	0	0.5	1.3	2.8	5.6

Missed APCH climb gradient MNM 4.0%

MINIMA		THR elev. 50		AD elev. 46		
CAT	CAT I		LOC		CIRCLING	
	DA(H)	RVR/CMV	MDA(H)	RVR/CMV	MDA(H)	VIS
A	250 (200)	700	490 (444)	1200	650 (604)	1600
B				1300		
C				1400	850 (804)	2400
D				1600		

MINIMA with Missed APCH climb gradient of 2.5% are not established.

INSTRUMENT APPROACH CHART

RJNA / NAGOYA

VOR RWY34

CENTRAIR APP 121.05 – 119.175 228.4 – 245.3	NAGOYA VORTAC 114.2 KCC CH-89X ☺☺☺ 35°15'55"N/136°54'54"E	NAGOYA TOWER 118.7 - 122.7 236.8 - 305.7	RADAR AVBL CALL CENTRAIR RADAR
---	--	--	-----------------------------------

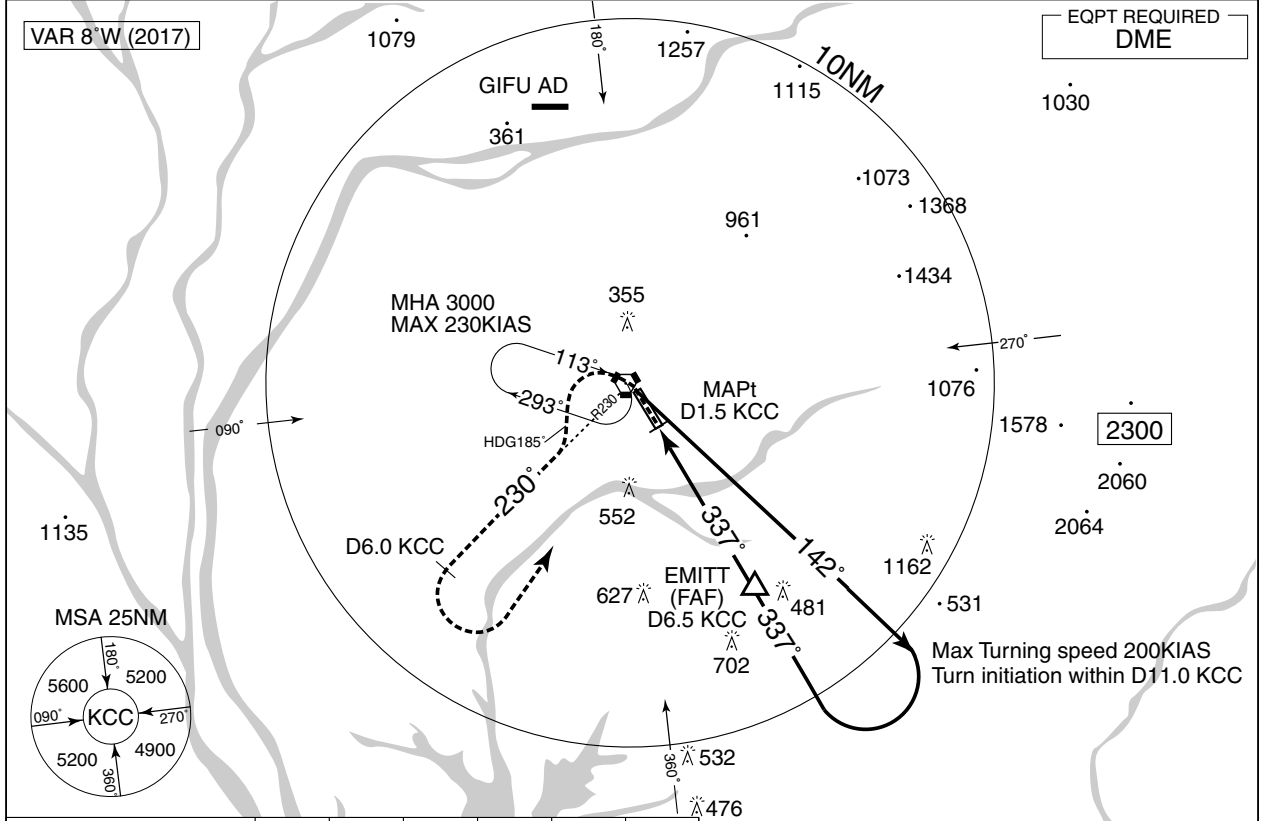

NM to KCC	MAPt	3	4	5	6	FAF
ALT (3.0° APCH Path)	-	584	902	1221	1539	1698

EMITT(FAF) : 351020.74N/1365900.12E

MISSED APPROACH

Turn left HDG185° to intercept and proceed via KCC R230 to KCC 6.0DME, turn left, direct to KCC VORTAC and hold at 3000FT. Contact CENTRAIR APP.

No turn before MAPt.
Timing not authorized for defining the MAPt.

DME to KCC	1.5	2.8	4.0	6.5
NM to THR	0	1.3	2.5	5.0

MINIMA		THR elev. 50	AD elev. 46	
CAT			CIRCLING	
	MDA(H)	RVR/CMV	MDA(H)	VIS
A	490 (444)	1200	650 (604)	1600
B		1300		
C		1400	850 (804)	2400
D		1600		

INSTRUMENT APPROACH CHART

RJNA / NAGOYA

VOR A

CENTRAIR APP 121.05 – 119.175 228.4 – 245.3	NAGOYA VORTAC 114.2 KCC CH-89X ≡≡≡ 35°15'55"N/136°54'54"E	NAGOYA TOWER 118.7 - 122.7 236.8 - 305.7	RADAR AVBL CALL CENTRAIR RADAR
---	--	--	-----------------------------------

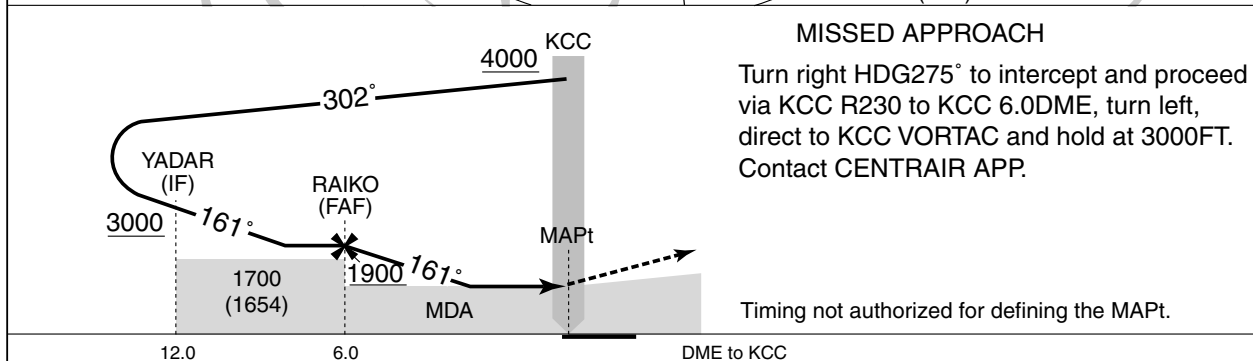
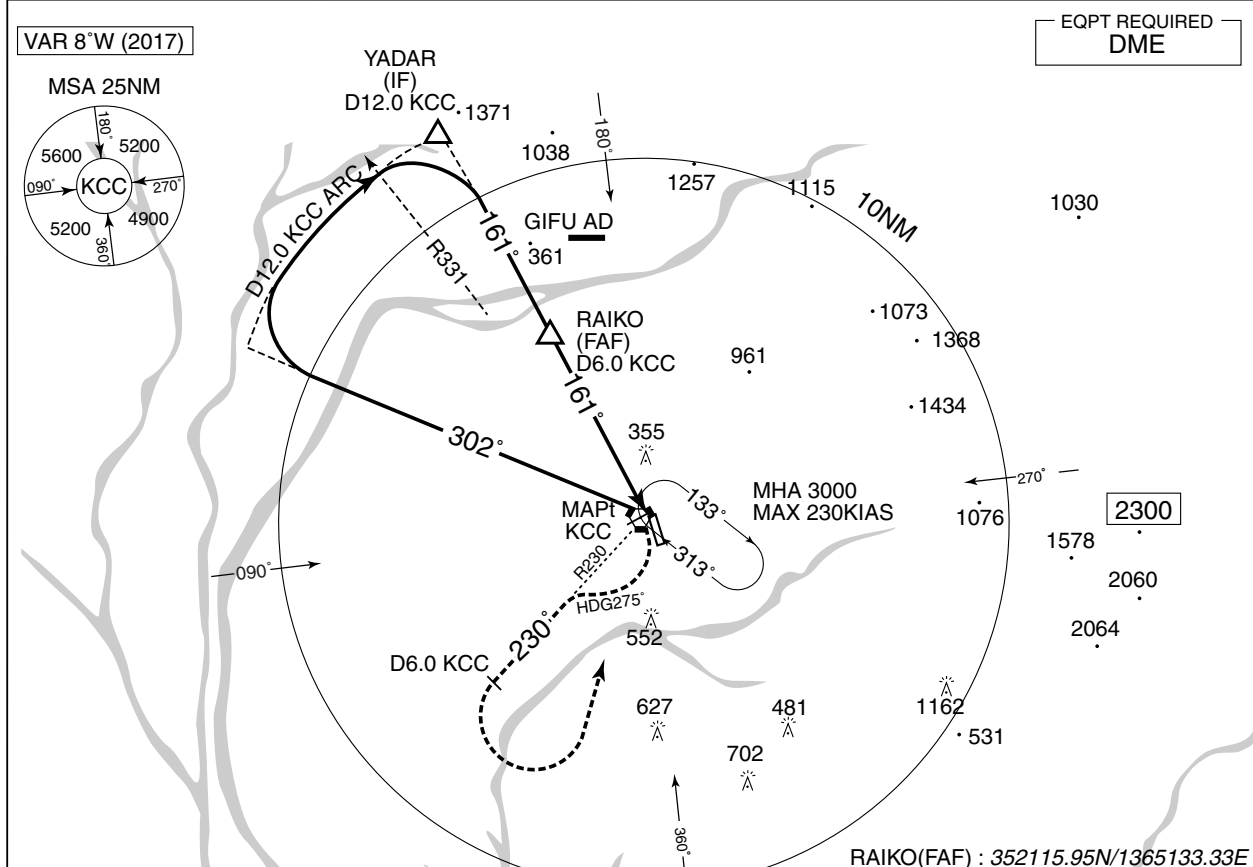

MINIMA		AD elev. 46
CAT	CIRCLING	
	MDA(H)	VIS
A	650 (604)	1600
B		2400
C		3200
D	690 (644)	

Circling to EAST side of RWY only.

INSTRUMENT APPROACH CHART

RJNA / NAGOYA

TACAN A

CENTRAIR APP 121.05 – 119.175 228.4 – 245.3	NAGOYA VORTAC 114.2 KCC CH-89X ≡≡≡: 35°15'55" N/136°54'54" E	NAGOYA TOWER 118.7 - 122.7 236.8 - 305.7	RADAR AVBL CALL CENTRAIR RADAR
---	---	--	-----------------------------------

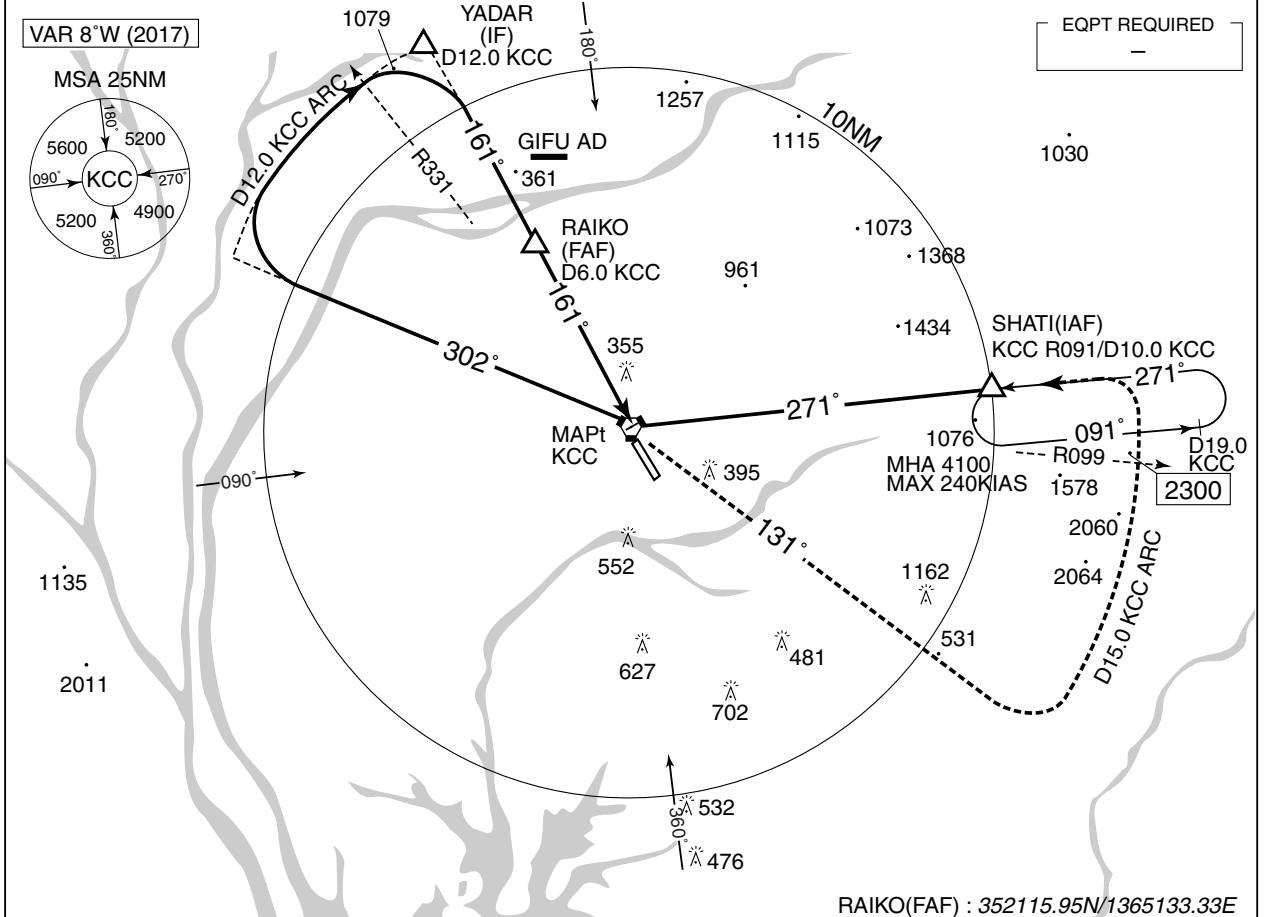

RAIKO(FAF) : 352115.95N/1365133.33E

MISSED APPROACH

Turn left, climb to 4100FT via KCC R131, turn left, via KCC 15.0DME counterclockwise ARC, turn left, via KCC R091 to SHATI and hold.
Contact CENTRAIR APP.

Timing not authorized for defining the MAPt.

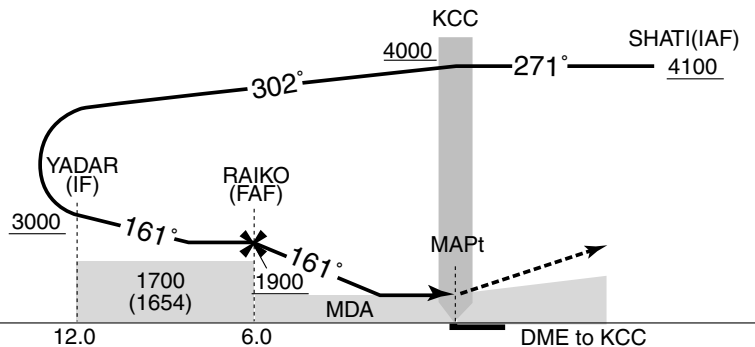

MINIMA		AD elev. 46	
CAT	CIRCLING		
	MDA(H)	VIS	
A	650 (604)	1600	
B		2400	
C	690 (644)	3200	
D			

Circling to EAST side of RWY only.

RJNA / NAGOYA

Visual REP

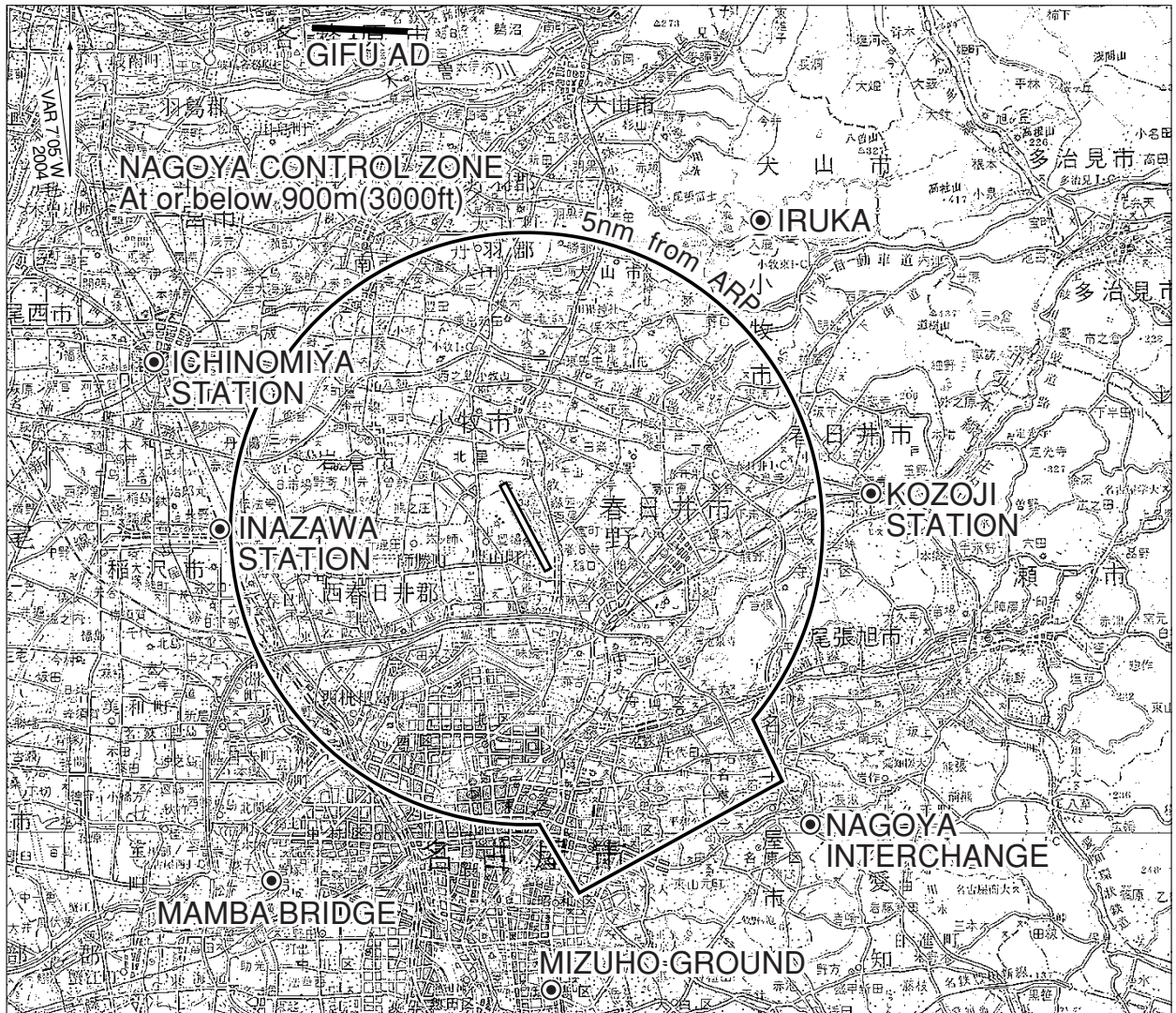

Call sign	BRG/DIST from ARP	Remarks
高蔵寺ステーション Kozoji Station	091° / 5.9NM	JR高蔵寺駅 Station
入鹿 Iruka	041° / 6.3NM	池 Pond
一宮ステーション Ichinomiya Station	301° / 6.8NM	JR 尾張一宮駅 Station
稲沢ステーション Inazawa Station	276° / 5.1NM	JR 稲沢駅 Station
万場大橋 Mamba Bridge	223° / 7.3NM	庄内川と名古屋高速5号万場線との交点 Bridge
*名古屋インターチェンジ Nagoya Interchange	143° / 6.9NM	東名高速道路のインターチェンジ Interchange
*瑞穂グラウンド Mizuho Ground	180° / 8NM	総合陸上競技場 Ground

注：*は特別管制空域に係る飛行の許可及び指示を受けるため、また、その他必要に応じて当該空域に係る位置通報等に供される目視位置通報点である。

Note : The asterisk (*) indicates the visual reporting point where a pilot is to request ATC clearance regarding to PCA and to make position report as required.

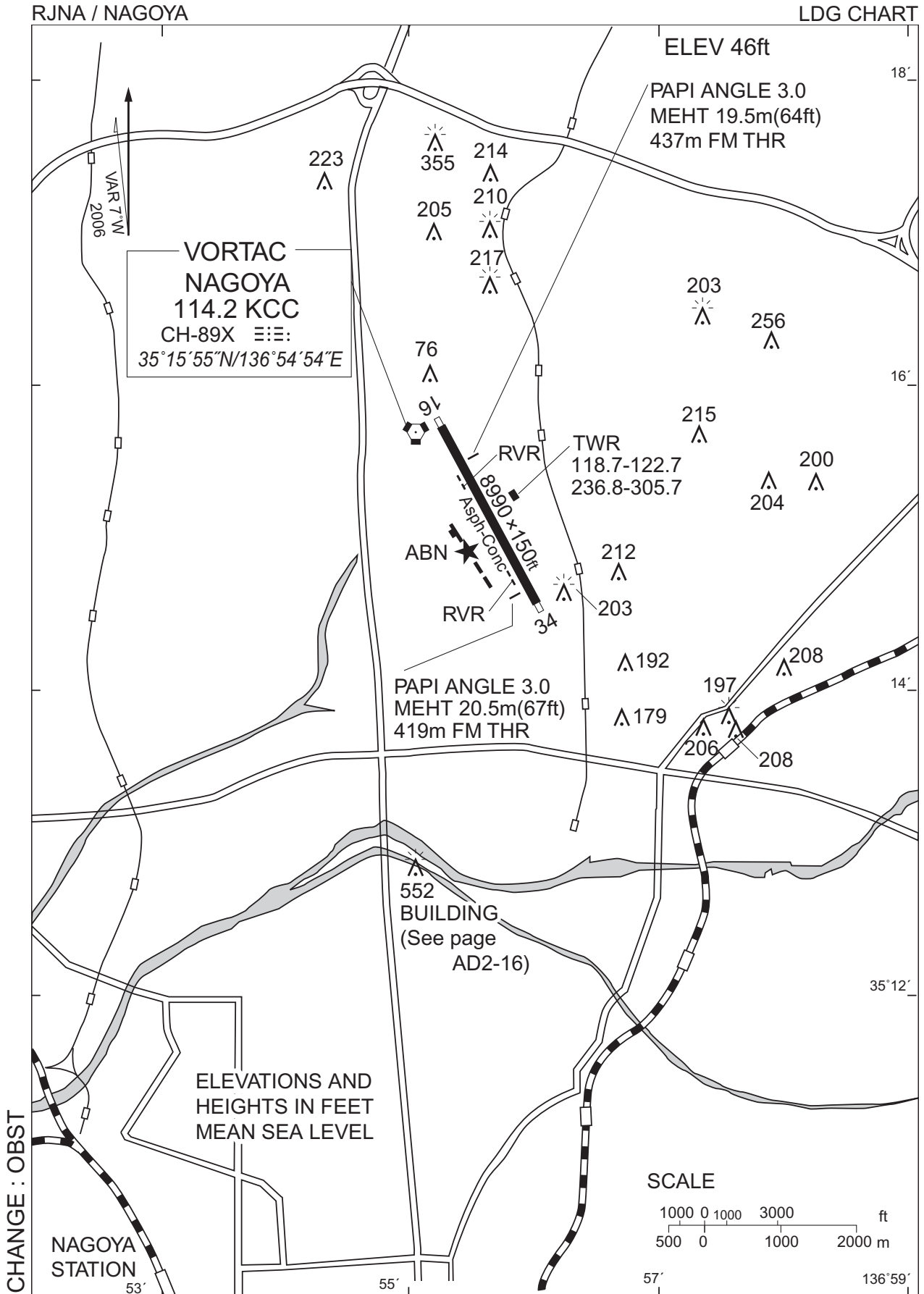

RJNA / NAGOYA

AIRCRAFT PARKING CHART

CHANGE: Spot 13A,14 installed

MARKING AIDS PARKING AREA

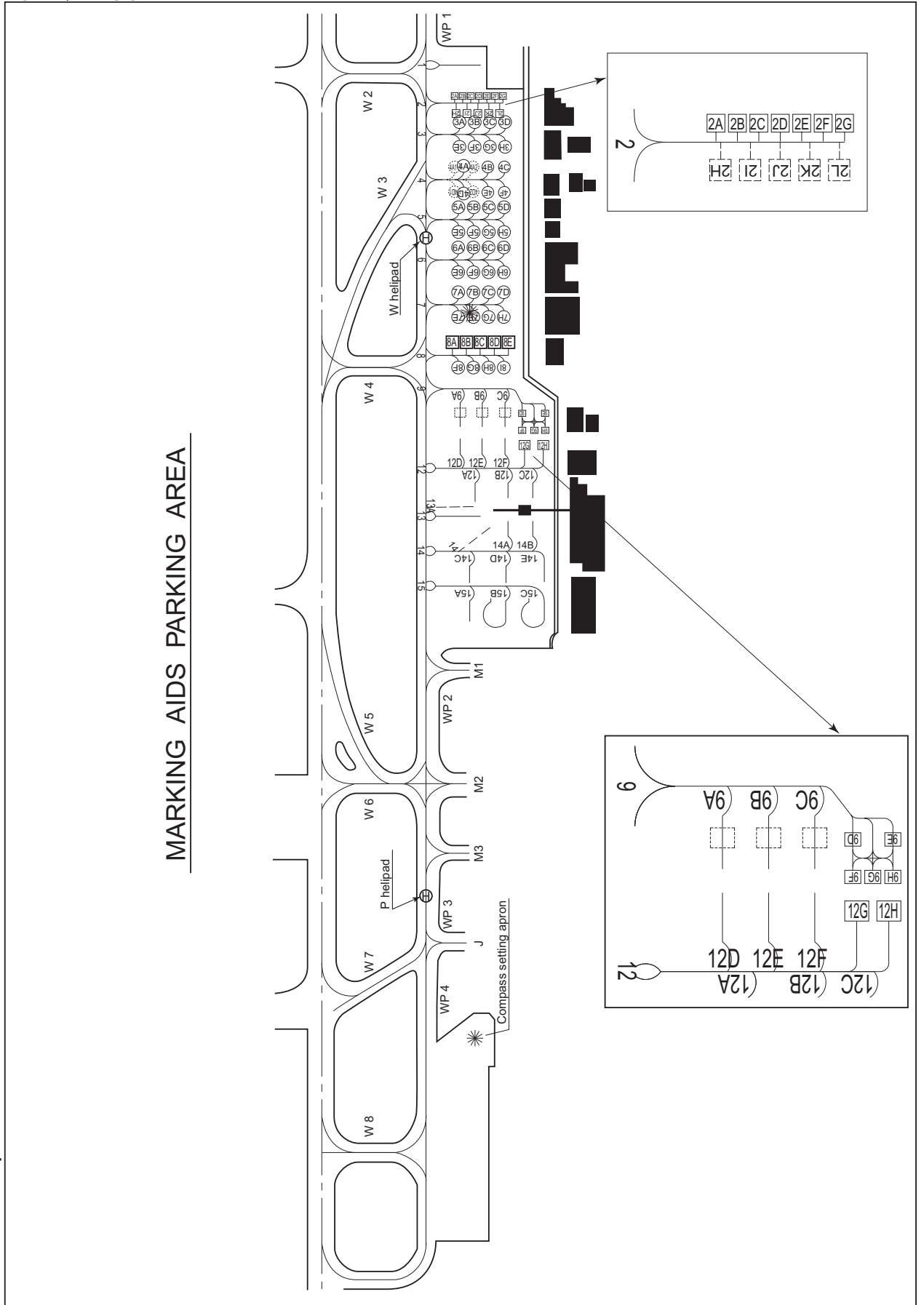

STANDARD DEPARTURE CHART -INSTRUMENT

RJNA / NAGOYA

SID

TALMI FOUR DEPARTURE

RWY16 : Climb RWY HDG to KCC 3.5DME, turn right HDG004°...

RWY34 : Climb RWY HDG to 700FT, turn left within 4NM from RWY end/KCC 4.0DME,...

...to intercept and proceed via KCC R319 to TALMI.

Cross TALMI at or above 7000FT.

Note RWY16 : 5.0% climb gradient required up to 700FT.

OBST ALT 551FT located at 1.9NM 215° FM end of RWY16.

RWY34 : 5.0% climb gradient required up to 700FT.

TALMI FOUR DEPARTURE

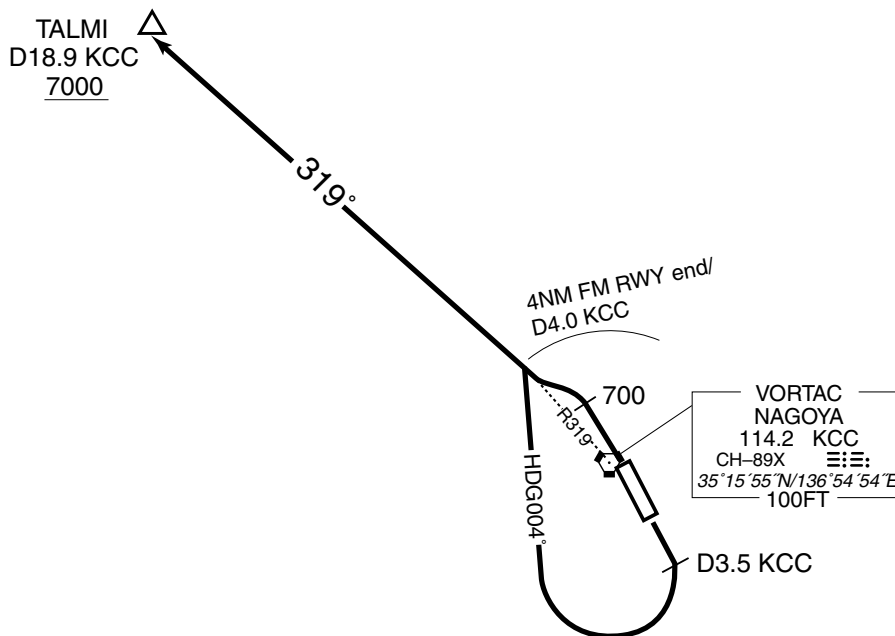

STANDARD DEPARTURE CHART -INSTRUMENT

RJNA / NAGOYA

RNAV TRANSITION

PIONE TRANSITION / WAKIT TRANSITION / KAMMY TRANSITION		RNAV 1
Note 1) DME/DME/IRU or GNSS required. 2) RADAR service required.	Critical DME	TZT : 10.0NM to PIONE - PIONE
	DME GAP	-
	Inappropriate Navaids	See AD1.1.6.10.3. Inappropriate NAVAIDS for RNAV1

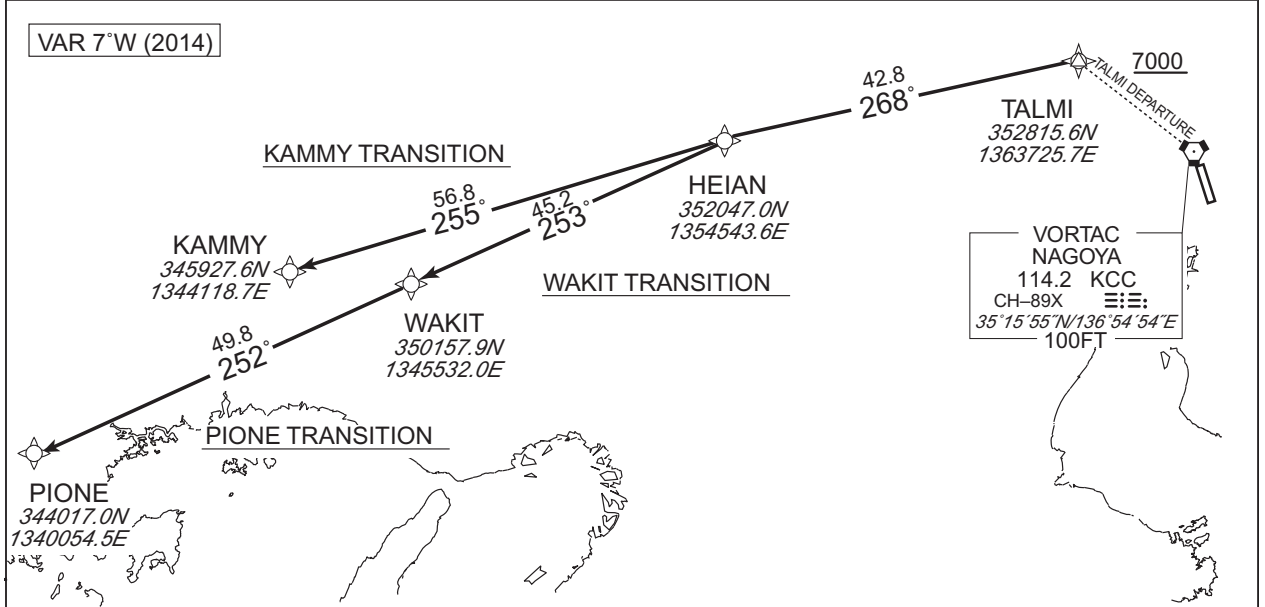

PIONE TRANSITION

From TALMI at or above 7000FT, to HEIAN, to WAKIT, to PIONE.

Serial Number	Path Descriptor	Waypoint Identifier	Fly Over	Course °M(°T)	Magnetic Variation	Distance (NM)	Turn Direction	Altitude (FT)	Speed (KIAS)	Vertical Angle	Navigation Specification
001	IF	TALMI	-	-	-7.3	-	-	+7000	-	-	RNAV1
002	TF	HEIAN	-	268 (260.2)	-7.3	42.8	-	-	-	-	RNAV1
003	TF	WAKIT	-	253 (245.6)	-7.3	45.2	-	-	-	-	RNAV1
004	TF	PIONE	-	252 (244.4)	-7.3	49.8	-	-	-	-	RNAV1

WAKIT TRANSITION

From TALMI at or above 7000FT, to HEIAN, to WAKIT.

Serial Number	Path Descriptor	Waypoint Identifier	Fly Over	Course °M(°T)	Magnetic Variation	Distance (NM)	Turn Direction	Altitude (FT)	Speed (KIAS)	Vertical Angle	Navigation Specification
001	IF	TALMI	-	-	-7.3	-	-	+7000	-	-	RNAV1
002	TF	HEIAN	-	268 (260.2)	-7.3	42.8	-	-	-	-	RNAV1
003	TF	WAKIT	-	253 (245.6)	-7.3	45.2	-	-	-	-	RNAV1

KAMMY TRANSITION

From TALMI at or above 7000FT, to HEIAN, to KAMMY.

Serial Number	Path Descriptor	Waypoint Identifier	Fly Over	Course °M(°T)	Magnetic Variation	Distance (NM)	Turn Direction	Altitude (FT)	Speed (KIAS)	Vertical Angle	Navigation Specification
001	IF	TALMI	-	-	-7.3	-	-	+7000	-	-	RNAV1
002	TF	HEIAN	-	268 (260.2)	-7.3	42.8	-	-	-	-	RNAV1
003	TF	KAMMY	-	255 (248.3)	-7.3	56.8	-	-	-	-	RNAV1

INTENTIONALLY LEFT BLANK

RJNA / NAGOYA

Minimum Vectoring Altitude CHART

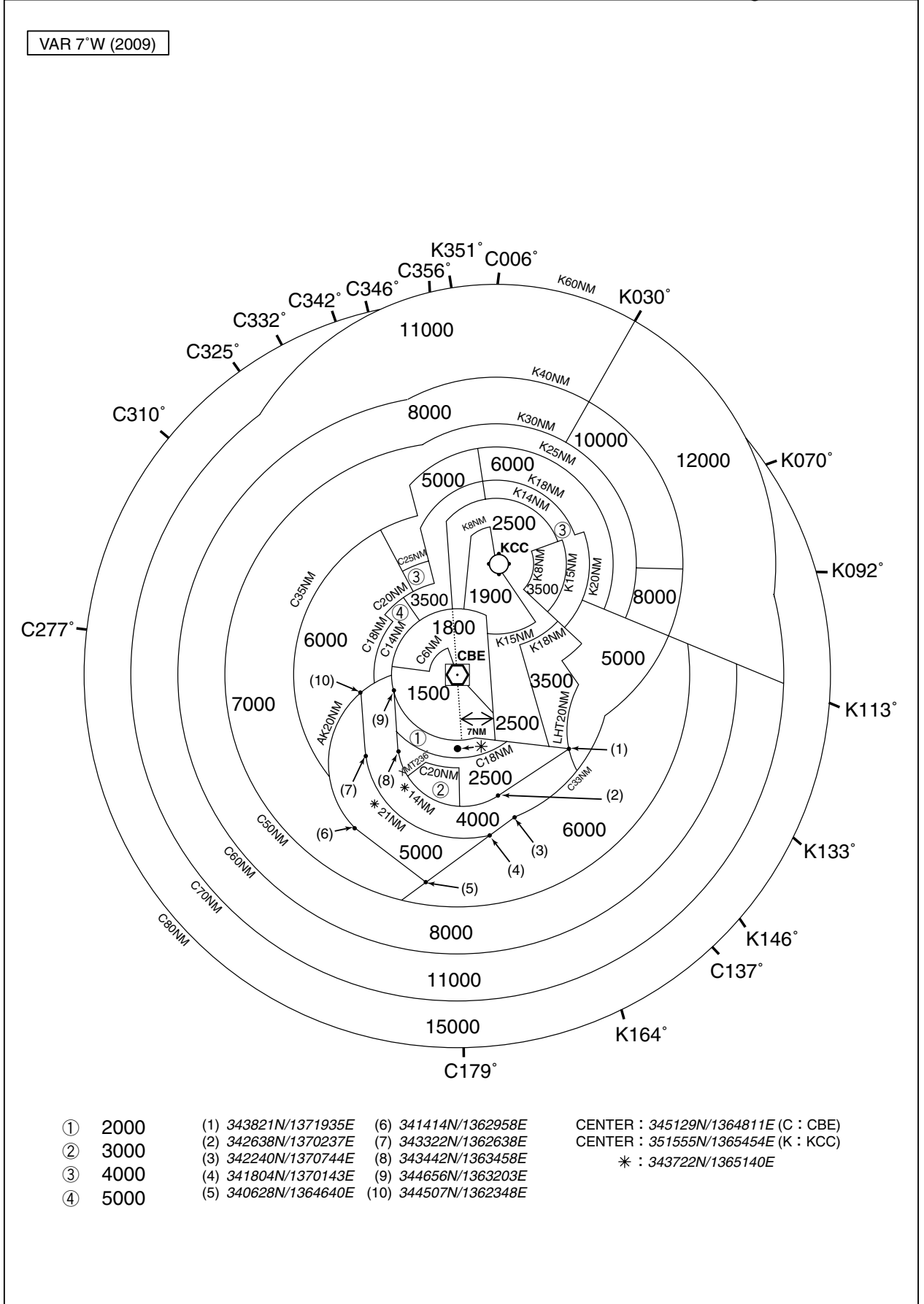

INSTRUMENT APPROACH CHART

RJNA / NAGOYA

RNAV(GNSS) RWY16

CENTRAIR APP 121.05 - 119.175 228.4 - 245.3	1.DME/DME not authorized. 2.RADAR service required. 3.GNSS required.	NAGOYA TOWER 118.7 - 122.7 236.8 - 305.7	RADAR AVBL CALL CENTRAIR RADAR
---	--	--	-----------------------------------

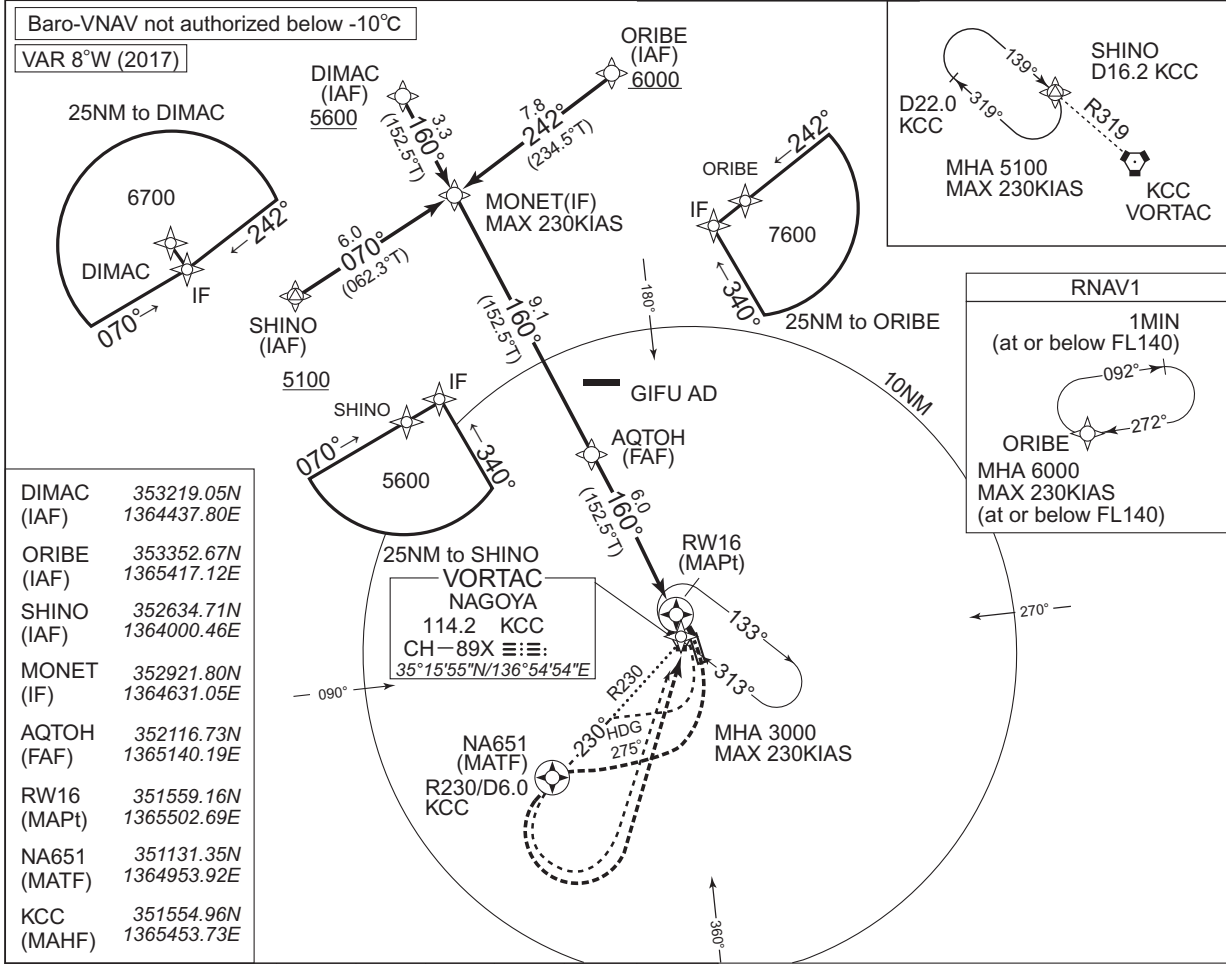

DIMAC (IAF)	353219.05N 1364437.80E
ORIBE (IAF)	353352.67N 1365417.12E
SHINO (IAF)	352634.71N 1364000.46E
MONET (IF)	352921.80N 1364631.05E
AQTOH (FAF)	352116.73N 1365140.19E
RW16 (MAPt)	351559.16N 1365502.69E
NA651 (MATF)	351131.35N 1364953.92E
KCC (MAHF)	351554.96N 1365453.73E

NM to Next Fix	FAF	5	4	3	2	MAPt
ALT (3.0° APCH Path)	2000	1693	1375	1057	738	-

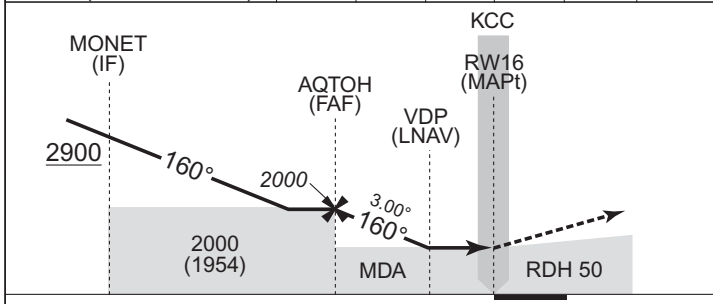

MISSED APPROACH
Turn right direct to NA651, turn left, direct to KCC and hold at 3000FT.
Contact CENTRAIR APP.
(For using VORTAC)
Turn right HDG275° to intercept and proceed via KCC R230 to KCC 6.0DME, turn left direct to KCC VORTAC and hold at 3000FT.
Contact CENTRAIR APP.

MINIMA		THR elev. 52		AD elev. 46		
CAT	LNAV/VNAV		LNAV		CIRCLING	
	DA(H)	RVR/CMV	MDA(H)	RVR/CMV	MDA(H)	VIS
A	610 (558)	1400	610 (564)	1400	650 (604)	1600
B		1500		1500		
C		1600		1600	690 (644)	3200
D		1800		1800		

Circling to EAST side of RWY only.

CHANGE : Correction of misdescription(DIMAC)

STANDARD DEPARTURE CHART -INSTRUMENT

RJNA / NAGOYA

SID and TRANSITION

IBUKI FOUR DEPARTURE

RWY16 : Climb RWY HDG to KCC 3.5DME, turn right HDG004° ...
 RWY34 : Climb RWY HDG to 700FT, turn left within 4NM from RWY end/KCC
 4.0DME,...
 ...to intercept and proceed via KCC R319 to IBUKI.
 Cross IBUKI at or above 11000FT.

Note RWY16 : 5.0% climb gradient required up to 700FT.
 OBST ALT 551FT located at 1.9NM 215° FM end of RWY16.
 RWY34 : 5.0% climb gradient required up to 700FT.

ADGUN TRANSITION

From over IBUKI, via KCC 29.5DME counterclockwise ARC
 to intercept and proceed via KCC R262 to ADGUN.
 Note : This TRANSITION is for TACAN equipped aircraft only.

OHNNO TRANSITION

From over IBUKI, via KCC 29.5DME clockwise ARC
 to intercept and proceed via KCC R348 to OHNNO.
 Cross KCC R336 at or above FL150.
 Note : This TRANSITION is for TACAN equipped aircraft only.

CHANGE : ADGUN TRANSITION, OHNNO TRANSITION established. OTSU TRANSITION, KOMATSU TRANSITION abolished.

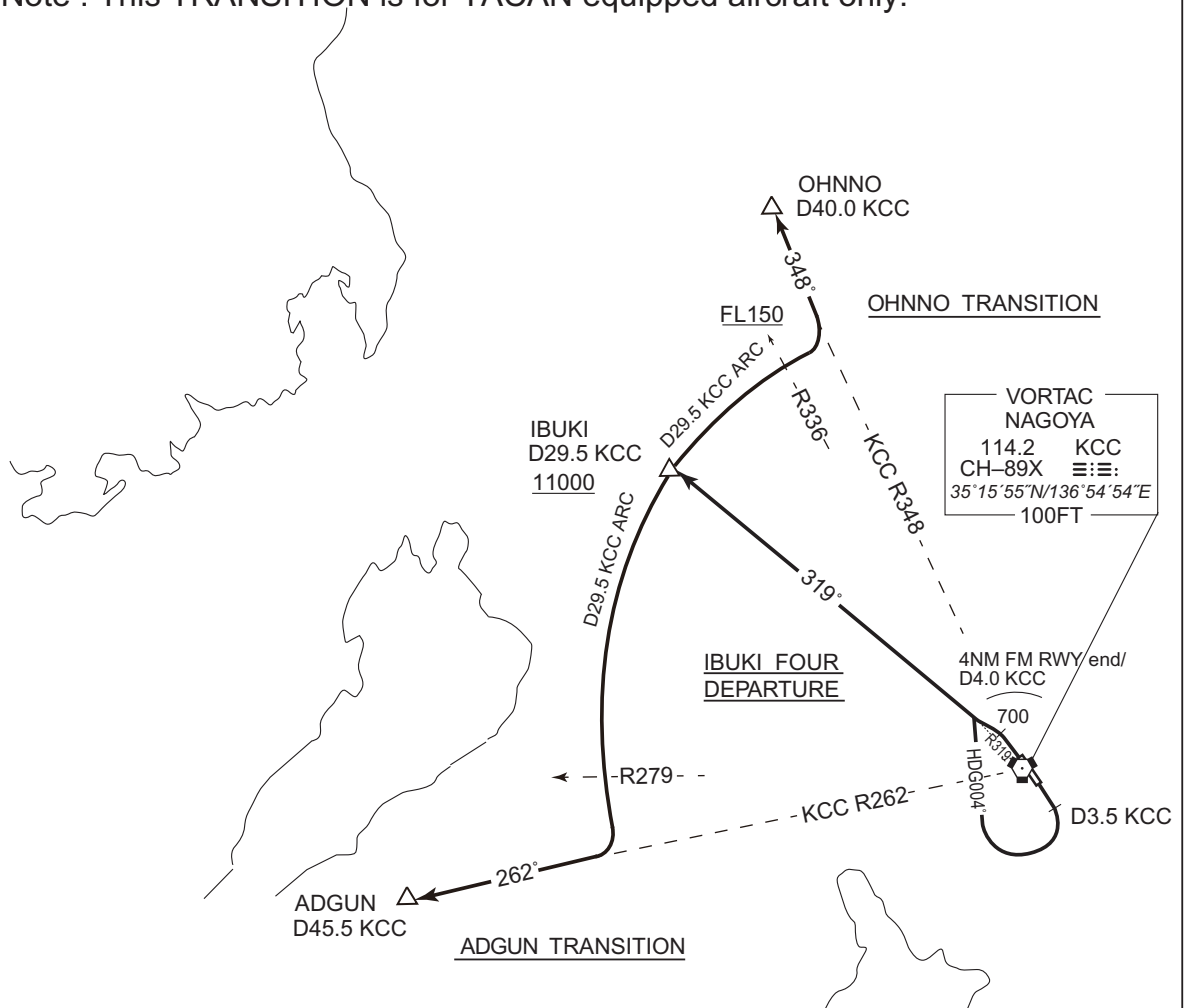

STANDARD DEPARTURE CHART -INSTRUMENT

RJNA / NAGOYA

RNAV TRANSITION

MIDER TRANSITION		RNAV1
NOTE 1) DME/DME/IRU or GNSS required. 2) RADAR service required.	Critical DME	-
	DME GAP	-
	Inappropriate Nav aids	See AD1.1.6.10.3. Inappropriate NAVAIDs for RNAV1

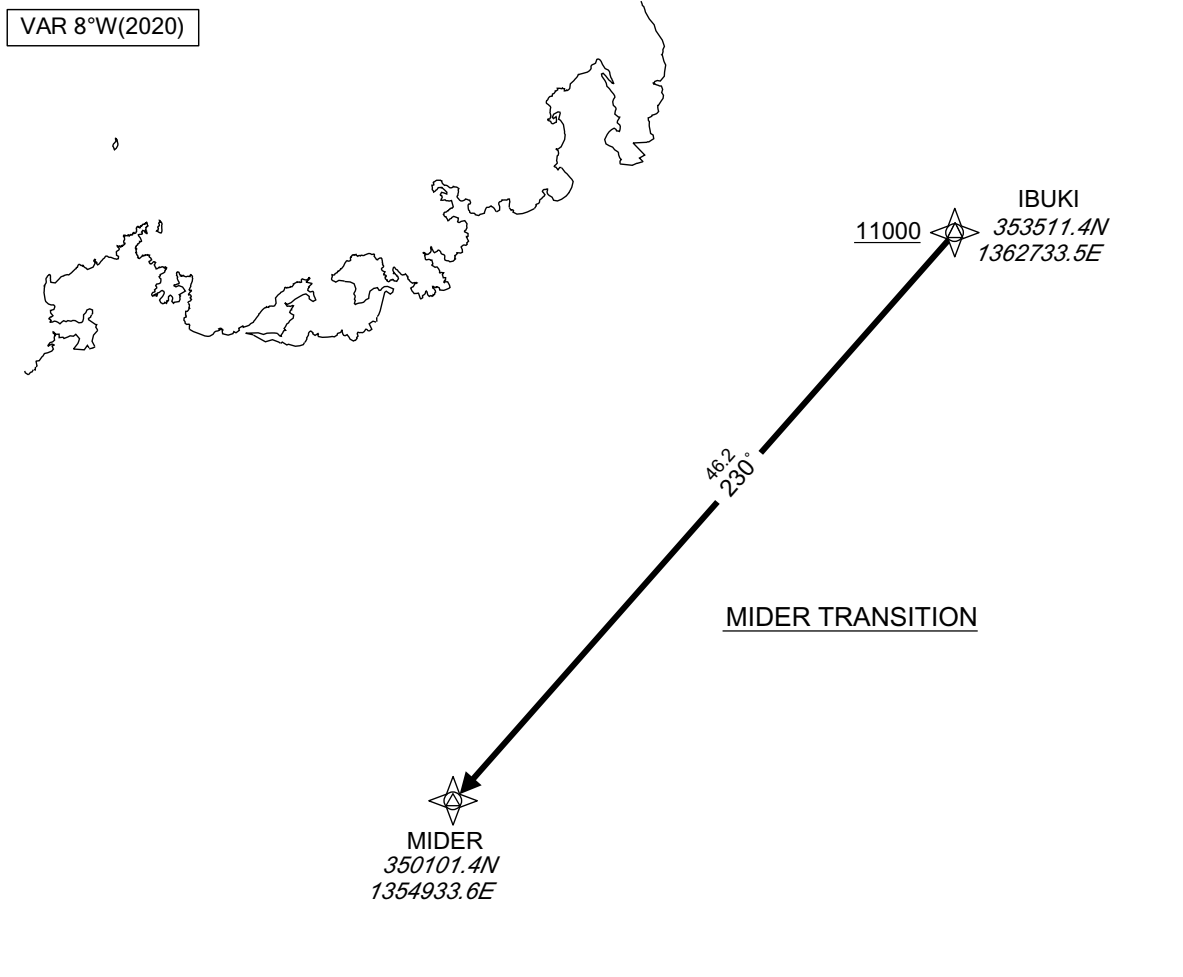

MIDER TRANSITION

From IBUKI at or above 11000FT, to MIDER.

Serial Number	Path Descriptor	Waypoint Identifier	Fly Over	Course °M(°T)	Magnetic Variation	Distance (NM)	Turn Direction	Altitude (FT)	Speed (KIAS)	Vertical Angle	Navigation Specification
001	IF	IBUKI	-	-	-7.9	-	-	+11000	-	-	RNAV1
002	TF	MIDER	-	230 (222.4)	-7.9	46.2	-	-	-	-	RNAV1

CHANGE : New PROC.

STANDARD DEPARTURE CHART -INSTRUMENT

RJNA / NAGOYA RNAV TRANSITION

KOMAZ TRANSITION	Critical DME	-
NOTE 1) DME/DME/IRU or GNSS required. 2) RADAR service required.	DME GAP	-
	Inappropriate NavAids	See AD1.1.6.10.3. Inappropriate NAVAIDs for RNAV1

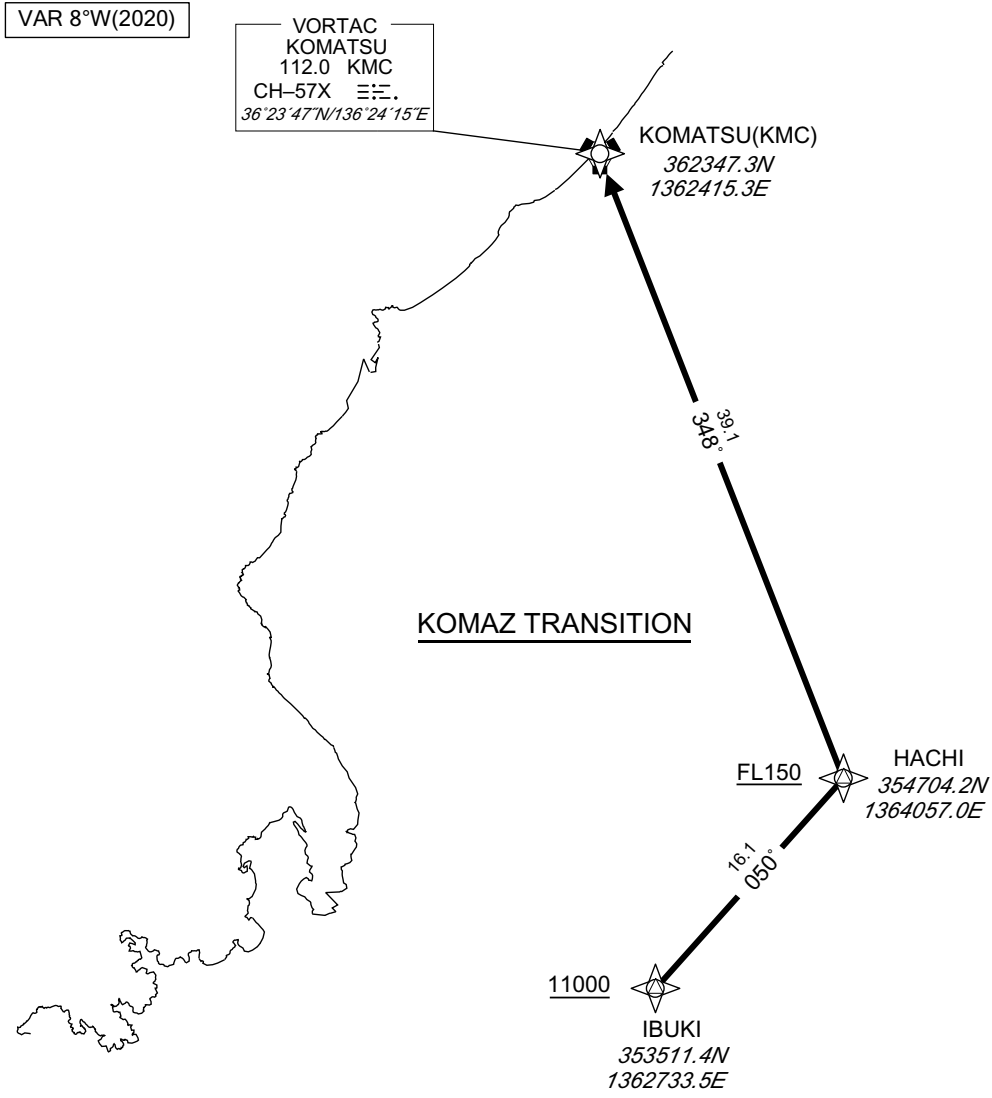

KOMAZ TRANSITION

From IBUKI at or above 11000FT, to HACHI at or above FL150, to KMC.

Serial Number	Path Descriptor	Waypoint Identifier	Fly Over	Course °M(°T)	Magnetic Variation	Distance (NM)	Turn Direction	Altitude (FT)	Speed (KIAS)	Vertical Angle	Navigation Specification
001	IF	IBUKI	-	-	-7.9	-	-	+11000	-	-	RNAV1
002	TF	HACHI	-	050 (042.4)	-7.9	16.1	-	+FL150	-	-	RNAV1
003	TF	KMC	-	348 (339.9)	-7.9	39.1	-	-	-	-	RNAV1

CHANGE : New PROC.

STANDARD DEPARTURE CHART -INSTRUMENT

RJNA / NAGOYA

SID

HOUBA FOUR DEPARTURE

RWY16 : Climb RWY HDG to 600FT, turn left HDG349° ...
 RWY34 : Climb RWY HDG to 700FT, turn right within 4NM from RWY end/
 KCC 4.0DME, via HDG079° ...
 ...to intercept and proceed via KCC R034 to HOUBA.
 Cross HOUBA at or above 8000FT.

Note RWY16 : 5.0% climb gradient required up to 600FT.
 RWY34 : 5.0% climb gradient required up to 700FT.

HOUBA FOUR DEPARTURE

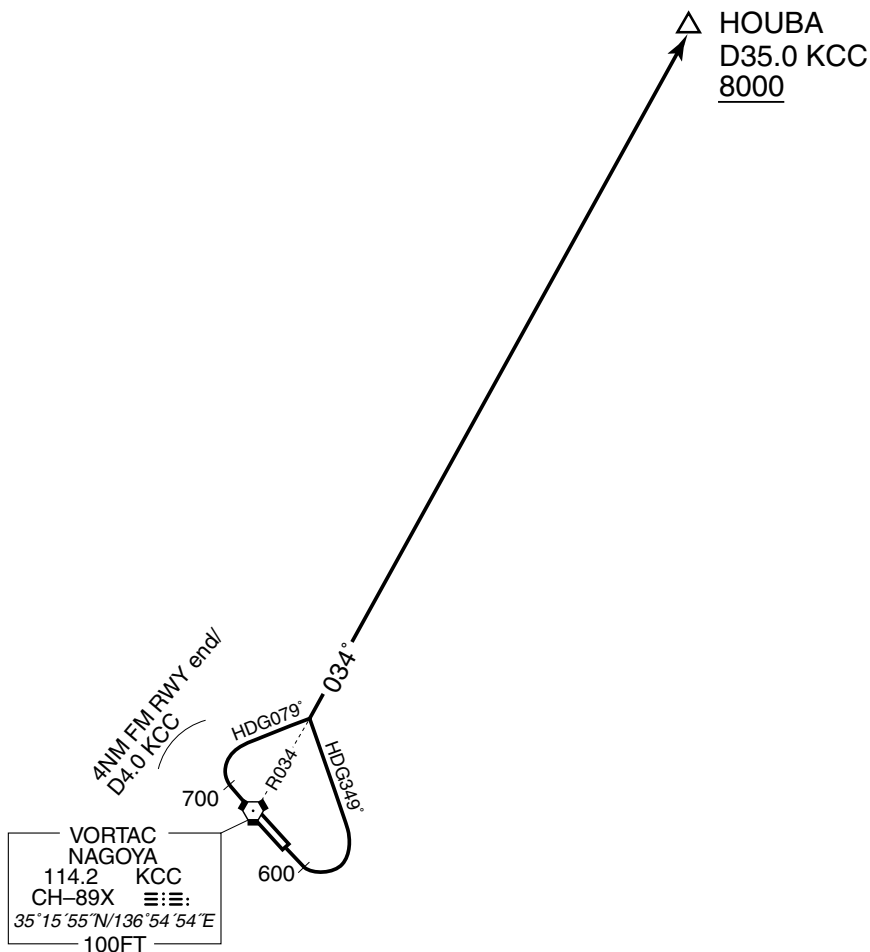

STANDARD DEPARTURE CHART -INSTRUMENT

RJNA / NAGOYA

TRANSITION

KROBE TRANSITION

From over HOUBA, via KCC R034 to KROBE via STRAW.
Cross STRAW at or above FL200.

NIIGATA TRANSITION

From over HOUBA, via KCC R034 to KROBE via STRAW, via GTC R227 to
GTC VORTAC.
Cross STRAW at or above FL200.

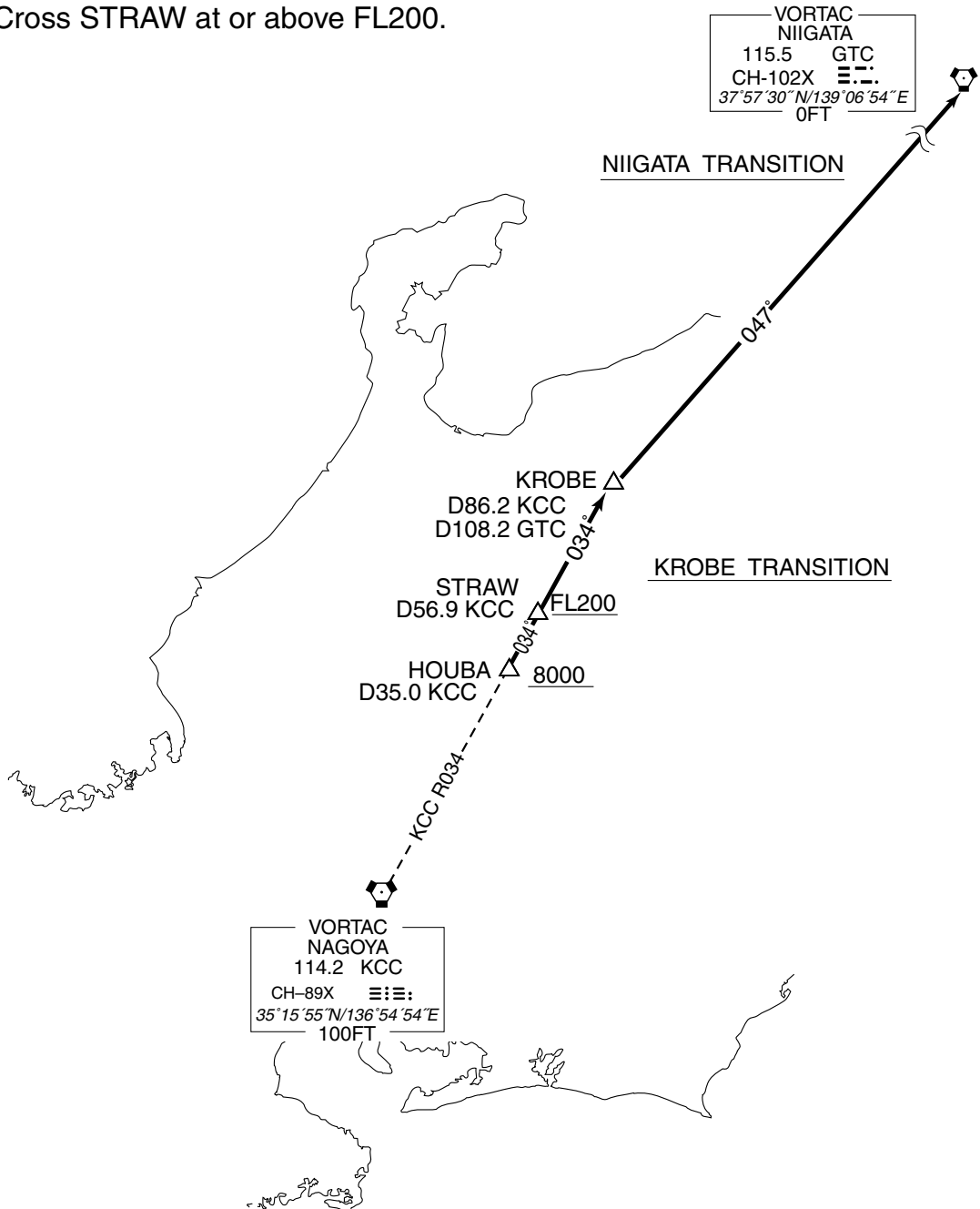

STANDARD DEPARTURE CHART -INSTRUMENT

RJNA / NAGOYA

SID

MORIZ FIVE DEPARTURE

RWY16 : Climb RWY HDG to 600FT, turn left,...

RWY34 : Climb RWY HDG to 700FT, turn right within 4NM from RWY end/KCC
4.0DME, via HDG182° to intercept and proceed...
...via KCC R137 to MORIZ.

(Cross KCC R137/10.0DME at or above 5000FT when using KCC TACAN only.)

Cross MORIZ at or above 7000FT.

Note RWY16 : 5.0% climb gradient required up to 600FT.
RWY34 : 5.0% climb gradient required up to 700FT.

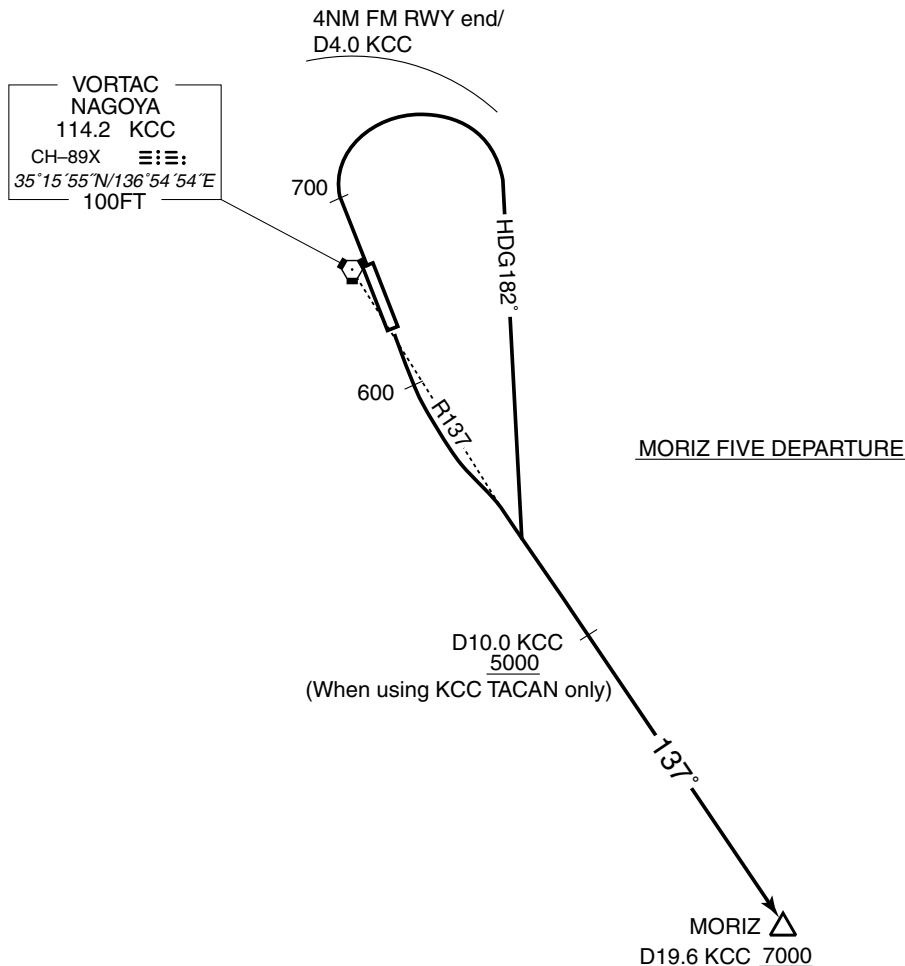

STANDARD DEPARTURE CHART -INSTRUMENT

RJNA / NAGOYA

TRANSITION

HAMAMATSU TRANSITION

From over MORIZ, via LHT R315 to LHT TACAN.

CHAUS TRANSITION

From over MORIZ, via CBE R067 to CHAUS via TSUGU.
Cross CHAUS at or above FL150.

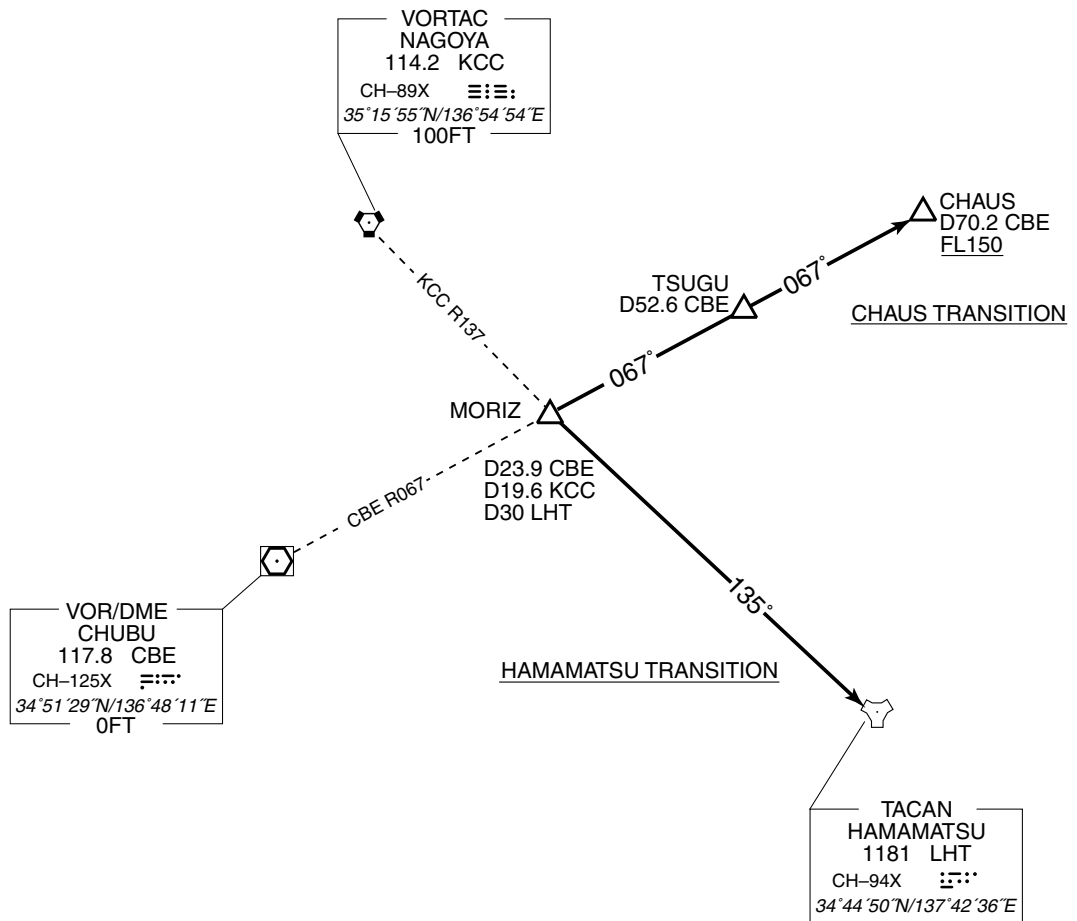

STANDARD DEPARTURE CHART -INSTRUMENT

RJNA / NAGOYA

TRANSITION

ALPUS TRANSITION

From over MORIZ, via CBE R067 to MUGEN via TSUGU, via KCC R088 to ALPUS.

Cross MUGEN at or above FL150.

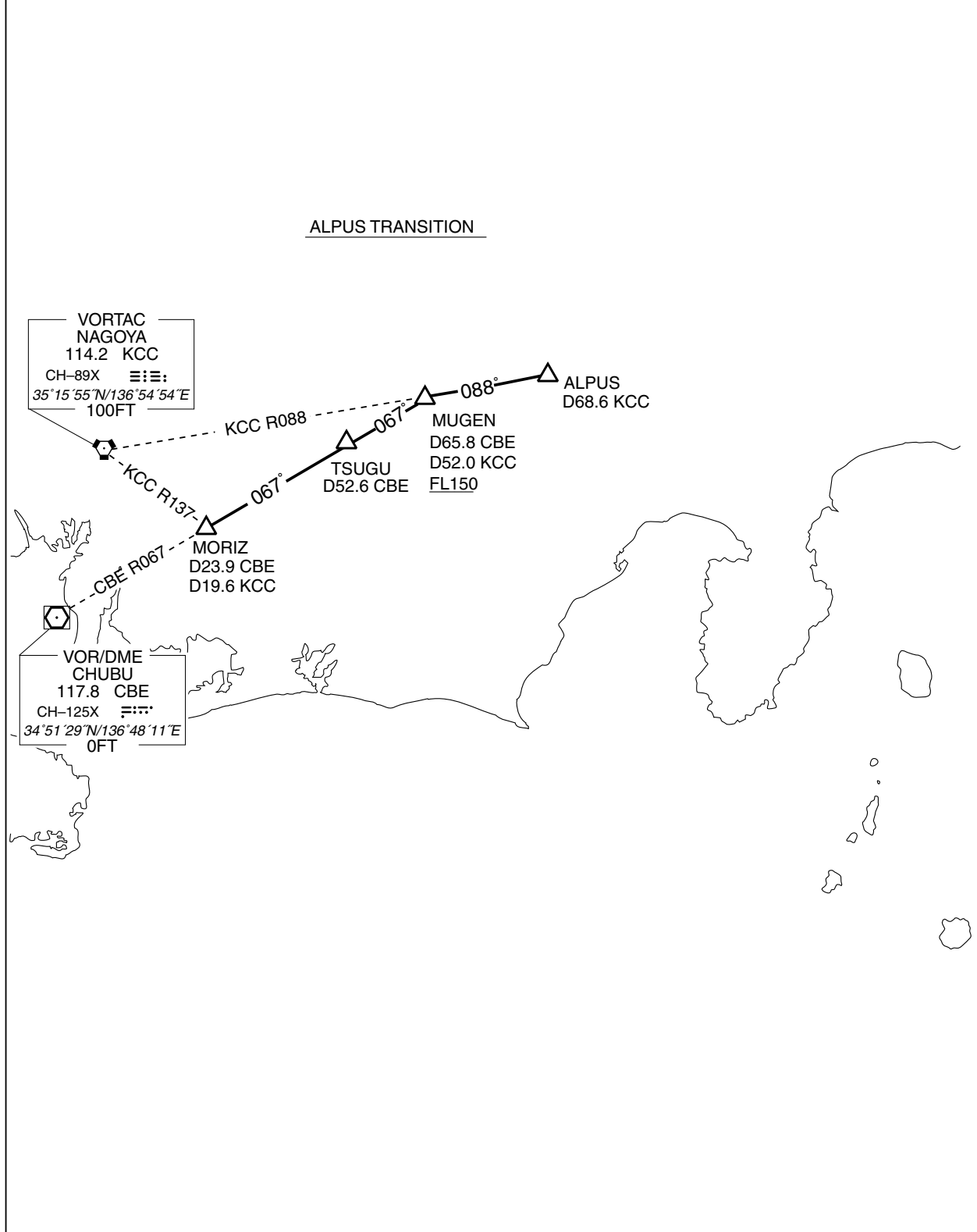

STANDARD DEPARTURE CHART -INSTRUMENT

RJNA / NAGOYA

TRANSITION

SHIMA TRANSITION

From over MORIZ, via CBE 23.9DME clockwise ARC to intercept and proceed via CBE R205 to SHIMA.

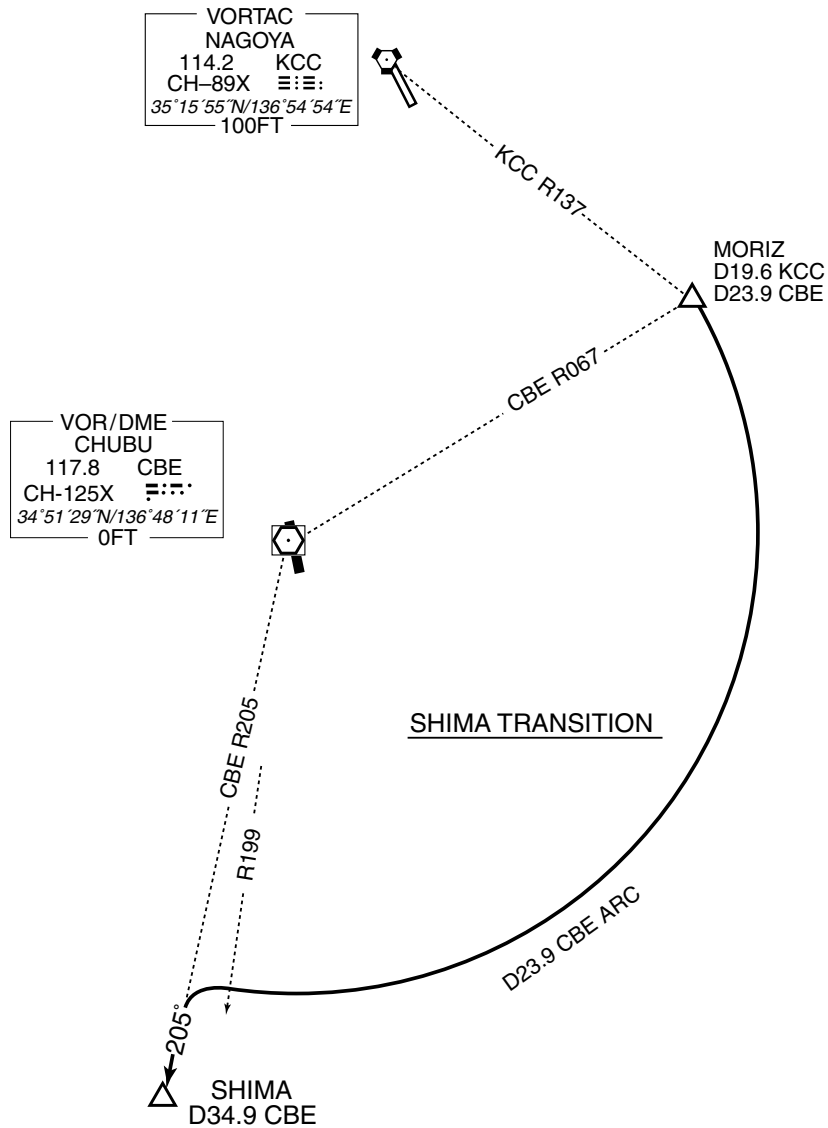

STANDARD DEPARTURE CHART -INSTRUMENT

RJNA / NAGOYA

SID

NAGOYA EAST REVERSAL ONE DEPARTURE

RWY16 : Climb RWY HDG to 600FT, turn left, direct to KCC VORTAC.
Cross KCC VORTAC at or above 3000FT.

RWY34 : Climb RWY HDG to 700FT, turn right within 4NM from RWY end/KCC 4.0DME,
direct to KCC VORTAC.
Cross KCC VORTAC at or above 3000FT.

Note RWY16 : 5.0% climb gradient required up to 600FT.
RWY34 : 5.0% climb gradient required up to 700FT.

NAGOYA EAST REVERSAL ONE DEPARTURE

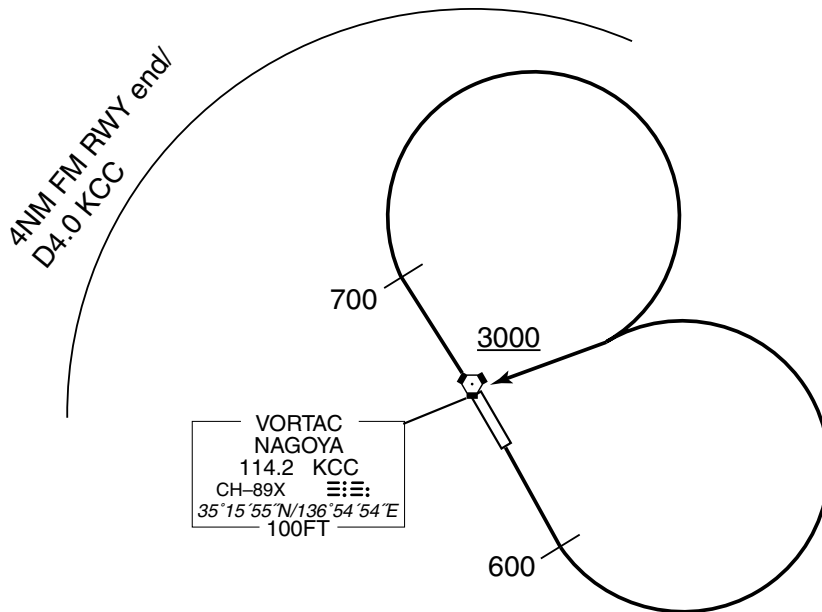

STANDARD DEPARTURE CHART -INSTRUMENT

RJNA / NAGOYA

SID

NAGOYA WEST REVERSAL ONE DEPARTURE

RWY16 : Climb RWY HDG to KCC 3.5DME, turn right, direct to KCC VORTAC.
Cross KCC VORTAC at or above 3000FT.

RWY34 : Climb RWY HDG to 700FT, turn left within 4NM from RWY end/KCC 4.0DME,
direct to KCC VORTAC.
Cross KCC VORTAC at or above 3000FT.

Note RWY16 : 5.0% climb gradient required up to 700FT.
OBST ALT 551FT located at 1.9NM 215° FM end of RWY16.
RWY34 : 5.0% climb gradient required up to 700FT.

NAGOYA WEST REVERSAL ONE DEPARTURE

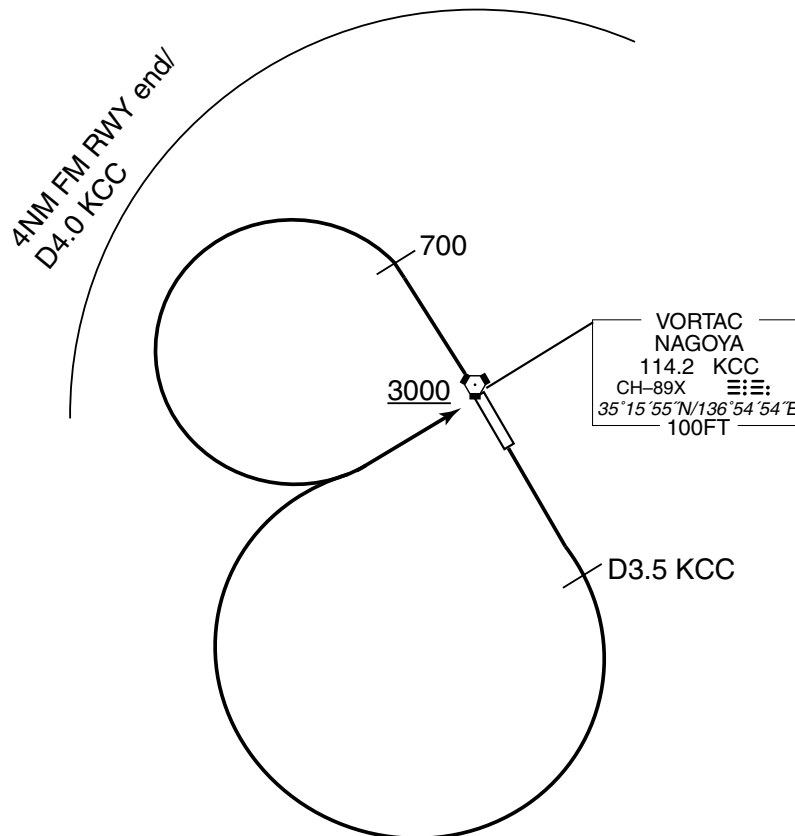

STANDARD ARRIVAL CHART -INSTRUMENT

RJNA / NAGOYA

STAR

EXPOH NORTH ARRIVAL

From over SWING, via KCC 18.4DME clockwise ARC to intercept and proceed via KCC R159 to EXPOH.

Cross KCC R151 at or above 3900FT, cross EXPOH at or above 2500FT.

EXPOH SOUTH ARRIVAL

From over SHIMA, via CBE R205, via CBE 24.0DME counterclockwise ARC to intercept and proceed via KCC R159 to EXPOH.

Cross KCC R159/23.0DME at or above 5000FT, cross EXPOH at or above 2500FT.

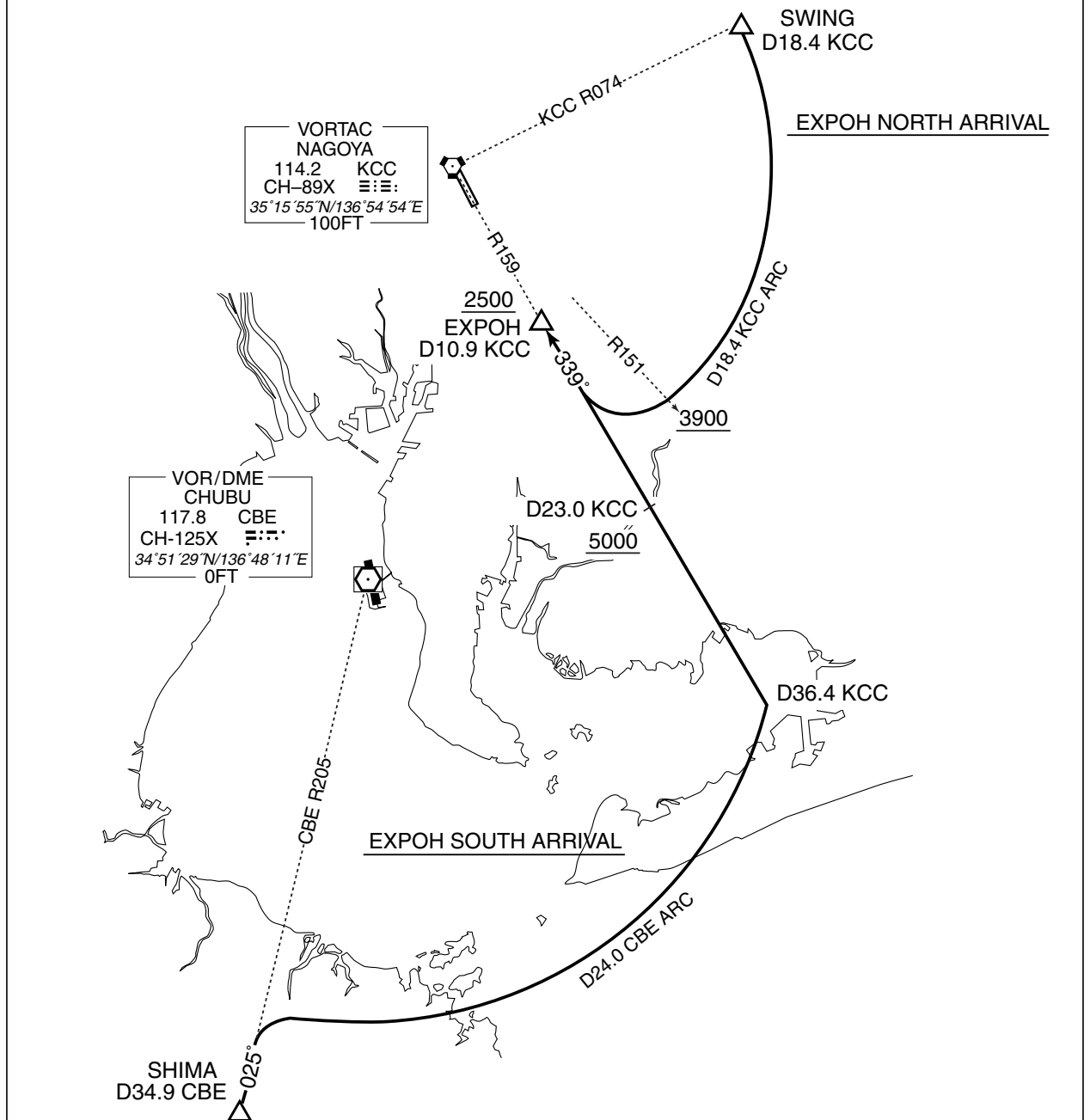

Airspace for the advisory service concerning low level wind shear

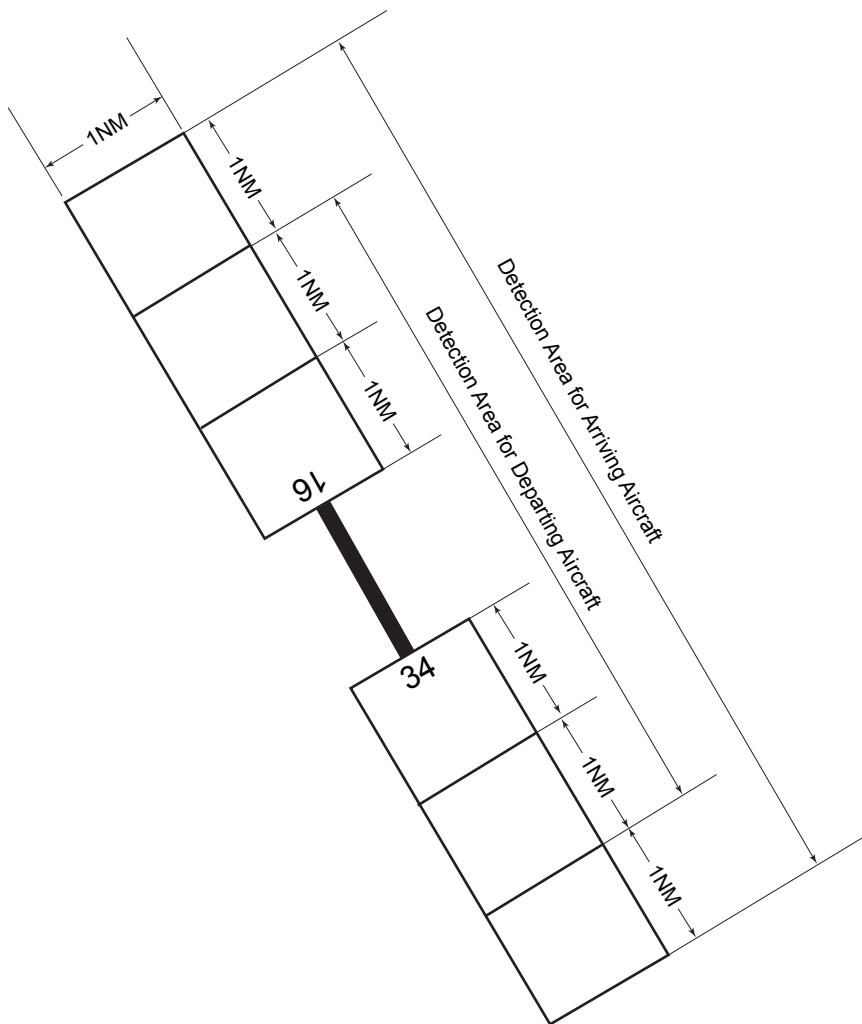

UPPER LIMIT : 1600ft above FIELD ELEV LEVEL

LOWER LIMIT : FIELD ELEV LEVEL

RWY16

RWY34

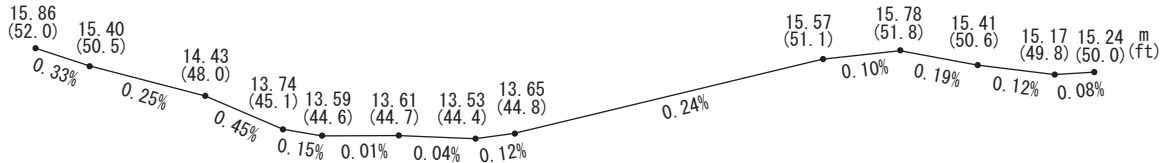

0m 140m 440m 640m 740m 940m 1140m 1240m 2040m 2240m 2440m 2640m 2740m

名古屋特別管制区
Nagoya Positive Control Area

NAME	LATERAL LIMITS	UPPER LIMIT (AMSL)	UNIT PROVIDING SERVICE	REMARKS
		LOWER LIMIT (AMSL) M(ft)		
1	2	3	4	5
名古屋 NAGOYA	下記に示される区域 The area shown below		Primary Centrair APP 121.05 119.175 228.4 245.3 Centrair Radar 125.55 Secondary Nagoya TWR 118.7 236.8 122.7 305.7	当該空域を飛行しようとする航空機は、Centrairアプローチ（Centrairレーダー）又は名古屋タワーに連絡し、現在位置、高度及び意図を通報し指示を受けること。 Pilot of aircraft operating in this area shall contact Centrair APP(RADAR) or Nagoya TWR, for ATC instructions giving informations on aircraft identification, position, altitude and pilot's intention.

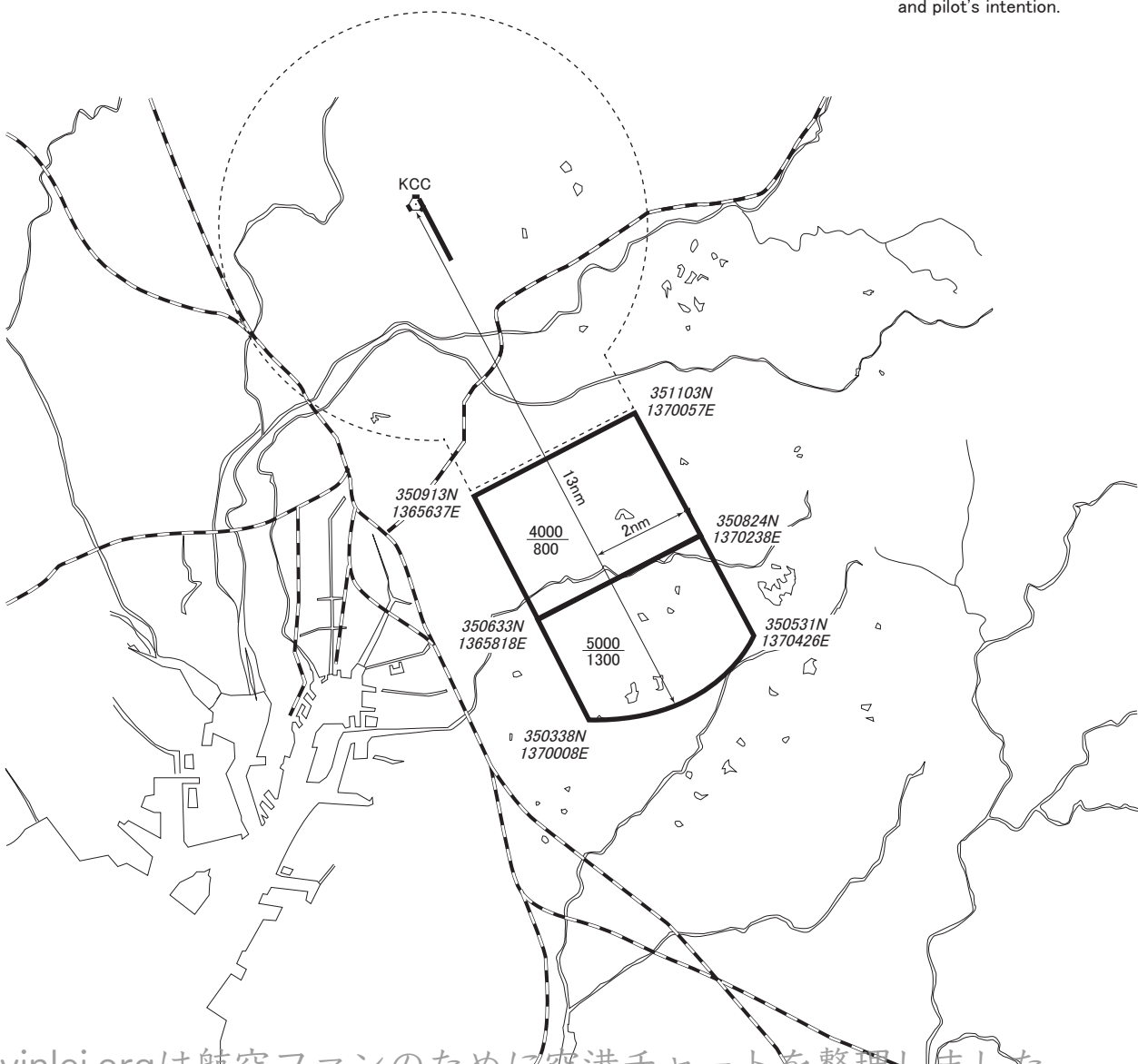

NAGOYA AIRPORT

ILS for RWY 34

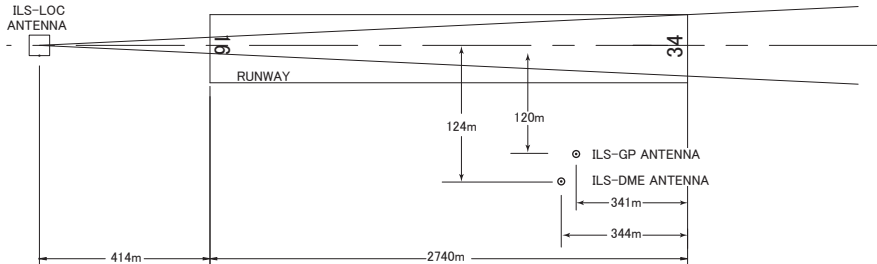

- REMARKS:
- | | |
|-------------------------|----------------|
| 1. LOC beam BRG(MAG) | 341° |
| 2. HGT of ILS REF datum | 16.8m (55ft) |
| 3. GP Angle | 3.0° |
| 4. ELEV of ILS-DME | 19.5m (63.8ft) |

建築物

- 1.位置 : $35^{\circ}12'58''/136^{\circ}54'47''$ (名古屋空港標点から南4.4km)
- See LDG CHART
- 2.高さ : 552FT (168m) MSL
525FT (160m) AGL
- 3.備考 : 中光度及び低光度航空障害灯が下図のとおり設置されている。

Building

- 1.Position : $35^{\circ}12'58''/136^{\circ}54'47''$ (4.4km S from NAGOYA ARP)
-See LDG CHART
- 2.Height : 552FT (168m) MSL
525FT (160m) AGL
- 3.Remarks : Medium-intensity and low-intensity obstacle lights are installed on this tower as shown in below figure.

- ☆ 中光度航空障害灯
Medium-intensity obstacle lights
- ★ 低光度航空障害灯
Low-intensity obstacle lights

