

AD 2 AERODROMES

RJFM AD 2.1 AERODROME LOCATION INDICATOR AND NAME

RJFM - MIYAZAKI

RJFM AD 2.2 AERODROME GEOGRAPHICAL AND ADMINISTRATIVE DATA

1	ARP coordinates and site at AD	315238N/1312655E 090°/1.25km from RWY 09 THR
2	Direction and distance from (city)	3.2km SSE from MIYAZAKI CITY
3	Elevation/ Reference temperature	19ft / 31°C(2002-2006)
4	Geoid undulation at AD ELEV PSN	92.114FT
5	MAG VAR/ Annual change	7° W(2020) / 5°W
6	AD Administration, address, telephone, telefax, telex, AFS, e-mail and/or Web-site addresses	Miyazaki Airport Office(CAB) Akae, Miyazaki-shi, Miyazaki Pref, 880-0912 JAPAN TEL: 0985-51-3223 FAX: 0985-55-1239 AFS: RJFMYFYX
7	Types of traffic permitted (IFR/VFR)	IFR/VFR
8	Remarks	Nil

RJFM AD 2.3 OPERATIONAL HOURS

1	AD Administration	2230 - 1230
2	Customs and immigration	Customs: 2330-0815 Immigration: INTL SKED FLT hours only
3	Health and sanitation	Quarantine(human): (MON,TUE,THU,FRI)2330-0815 (WED)2330-0930 (SAT)0100-0930 (SUN)0130-1000 Quarantine(animal, plant): INTL SKED FLT hours only
4	AIS Briefing Office	2230 - 1230
5	ATS Reporting Office(ARO)	Nil
6	MET Briefing Office	H24 (FUKUOKA)
7	ATS	2230 - 1230
8	Fuelling	2130 - 1200
9	Handling	2130 - 1230
10	Security	2200 - 1130
11	De-icing	Nil
12	Remarks	Nil

RJFM AD 2.4 HANDLING SERVICES AND FACILITIES

1	Cargo-handling facilities	Except Freighter
2	Fuel/ oil types	Fuel grades: JET A-1, AVGAS 100 Oil grades: Piston:W80, W100 Turbo: MJO2
3	Fuelling facilities/ capacity	Fuel tank 500kl x 4(JET A-1) 100kl x 1(Octane) Tanker car x 10
4	De-icing facilities	Nil
5	Hangar space for visiting aircraft	Nil
6	Repair facilities for visiting aircraft	Nil
7	Remarks	Nil

RJFM AD 2.5 PASSENGER FACILITIES

1	Hotels	Hotels in the city
2	Restaurants	At Airport
3	Transportation	Train, Buses and Taxi
4	Medical facilities	Hospital is the south side of airport
5	Bank and Post Office	Only ATM at airport
6	Tourist Office	Nil
7	Remarks	Nil

RJFM AD 2.6 RESCUE AND FIRE FIGHTING SERVICES

1	AD category for fire fighting	CAT 9
2	Rescue equipment	Chemical fire fighting truck x 3 Water-supply truck Lighting power supply truck Emergency medical equipments conveyance truck
3	Capability for removal of disabled aircraft	Ask AD Administration
4	Remarks	Nil

RJFM AD 2.7 SEASONAL AVAILABILITY-CLEARING

1	Types of clearing equipment	AVBL, Ask AD Administration for detail.
2	Clearance priorities	Nil
3	Remarks	Nil

RJFM AD 2.8 APRONS, TAXIWAYS AND CHECK LOCATIONS DATA

1	Apron surface and strength	SPOT 1-10 : Surface: Cement Concrete Strength: PCN 74/R/B/X/T SPOT 11 : Surface: Cement Concrete Strength: PCN 74/R/C/X/T SPOT 12-17 : Surface: Asphalt Concrete Strength: PCN 58/F/C/X/T
2	Taxiway width, surface and strength	S1 : 26.5m Asphalt Concrete PCN 97/F/C/X/T S2 : 28.5m Asphalt Concrete PCN 72/F/A/X/T S3, S4, S5 : 34m Asphalt Concrete PCN 69/F/B/X/T S6 : 30m Asphalt Concrete PCN 59/F/A/X/T S7 : 28.5m Asphalt Concrete PCN 72/F/A/X/T SP1 : 23m Asphalt Concrete PCN 109/F/C/X/T SP2, SP3 : 23m Cement Concrete PCN 74/R/C/X/T SP4, SP5 : 23m Asphalt Concrete PCN 104/F/C/X/T SP6 : 23m Asphalt Concrete PCN 72/F/A/X/T N1 - N4 : 18m Asphalt Concrete 5,700kg/0.48MPa NP1 - NP3 : 18m Asphalt Concrete 5,700kg/0.48MPa
3	ACL and elevation	Not Available
4	VOR checkpoints	Not Available
5	INS checkpoints	Spot NR 1: 315225.14N,1312642.38E 2: 315225.02N,1312640.72E 3: 315225.55N,1312639.35E 5: 315225.41N,1312637.25E 6: 315224.75N,1312634.45E 7: 315224.53N,1312632.04E 8: 315224.31N,1312629.39E 9: 315224.15N,1312626.73E 10: 315224.01N,1312624.07E 11: 315223.73N,1312621.42E
6	Remarks	Nil

RJFM AD 2.9 SURFACE MOVEMENT GUIDANCE AND CONTROL SYSTEM AND MARKINGS

1	Use of aircraft stand ID signs, TWY guide lines and Visual docking/ parking guidance system of aircraft stands	Signification ACFT stand ID signs : NR6 - NR11
2	RWY and TWY markings and LGT	<p>RWY: RWY09/27 (Marking): RWY designation, RWY CL, RWY THR, RWY middle point, Aiming point, TDZ, RWY side stripe (LGT): RCLL, REDL, RTHL, RENL, WBAR</p> <p>TWY:ALL TWY (Marking):TWY CL, TWY side stripe (LGT): TWY edge LGT</p> <p>TWY:TWY S1-S5, S6, S7, SP1-SP4, SP5, SP6, SP7 (LGT): TWY CL LGT</p> <p>TWY:TWY S1-S7 (Marking): RWY HLDG PSN, Mandatory instruction (LGT): RWY guard LGT, Taxiing guidance sign</p> <p>TWY:TWY N1-N4 (Marking): RWY HLDG PSN, Mandatory instruction (LGT): Taxiing guidance sign</p>
3	Stop bars	<p>Stop bar LGT: S1-S7 Stop bar LGT operations</p> <ol style="list-style-type: none"> 1) Stop bar LGT are installed at each RWY holding position associated with RWY 09/27. 2) Stop bar LGT will be operated when the visibility or the lowest RVR of RWY 09/27 is at or less than 600m. 3) Stop bar LGT on TWY S1, S7 are controlled individually by ATC. 4) Stop bar LGT on TWY S2 through S6 are not controlled individually by ATC. 5) During the period Stop bar LGT operated, TWY S2 through S6 are not available for departure aircraft.
4	Remarks	<p>(Marking): Overrun area (LGT): Apron flood LGT</p>

RJFM AD 2.10 AERODROME OBSTACLES

In Area2 See Obstacle data

In Area3 To be developed

RJFM AD 2.11 METEOROLOGICAL INFORMATION PROVIDED

1	Associated MET Office	FUKUOKA
2	Hours of service MET Office outside hours	H24 (FUKUOKA)
3	Office responsible for TAF preparation Periods of validity	FUKUOKA 30 Hours
4	Trend forecast Interval of issuance	Nil
5	Briefing/ consultation provided	Briefing is available upon inquiry at FUKUOKA
6	Flight documentation Language(s) used	C En
7	Charts and other information available for briefing or consultation	S ₆ , U ₈₅ , U ₇ , U ₅ , U ₃ , U ₂₅ , U ₂ /Tr, P _S , P ₅ , P ₃ , P ₂₅ , P _{SWE} , P _{SWF} , P _{SWG} , P _{SWI} , P _{SWM} , P _{SW} (domestic), E, C, W _E , W _F , W _G , W _I , W, N
8	Supplementary equipment available for providing information	Nil
9	ATS units provided with information	TWR, APP, ATIS
10	Additional information(limitation of service, etc.)	Nil

RJFM AD 2.12 RUNWAY PHYSICAL CHARACTERISTICS

Designations RWY NR	TRUE BRG	Dimensions of RWY(M)	Strength(PCN) and surface of RWY	THR coordinates THR geoid undulation	THR elevation and highest elevation of TDZ of precision APP RWY
1	2	3	4	5	6
09	085.18°	2500×45	PCN 114/F/D/X/T Asphalt Concrete	315234.26N 1312607.02E 92.52FT	THR ELEV:15FT TDZ ELEV:17FT
27	265.18°	2500×45		315241.06N 1312741.80E 91.73FT	THR ELEV:20.7FT TDZ ELEV:20.7FT
Slope of RWY	Strip Dimensions(M)	RESA (Overrun) Dimensions (M)	Remarks		
7	10	11	14		
See AD CHART	2620×300 2620×300	36×(MNM:190 MAX:300)* 123×(MNM:139 MAX:249)*	RWY Grooving : 2500m x 30m		
*For detail, ask airport administrator					

RJFM AD 2.13 DECLARED DISTANCES

RWY Designator	TORA (m)	TODA (m)	ASDA (m)	LDA (m)	Remarks
1	2	3	4	5	6
09	2500	2500	2500	2500	Nil
27	2500	2500	2500	2500	Nil

RJFM AD 2.14 APPROACH AND RUNWAY LIGHTING

RWY Designator	APCH LGT type LEN INTST	RTHL Color WBAR	PAPI (VASIS) Angle DIST FM THR MEHT	RTZL LEN	RCLL LEN Spacing Color INTST	REDL LEN Spacing Color INTST	RENL Color WBAR	STWL LEN Color
1	2	3	4	5	6	7	8	9
09	SALS (*1) 420m LIH	Green -	PAPI 3.0° /LEFT 445m 74.5ft	Nil	2500m 30m Coded color (White/Red) LIH	2500m 60m Coded color (White/Yellow) LIH	Red	Nil(*2)
27	Nil	Green Green	PAPI 3.0° /LEFT 420m 66ft	Nil	2500m 30m Coded color (White/Red) LIH	2500m 60m Coded color (White/Yellow) LIH	Red	Nil(*2)
Remarks								
10								
SALS with APCH LGT beacon(592m and 847m FM RWY THR)(*1) Overrun area edge LGT(LEN:60m Color:Red)(*2) CGL for RWY 09 RWY THR ID LGT for RWY 27 THR (Color: White)								

RJFM AD 2.15 OTHER LIGHTING, SECONDARY POWER SUPPLY

1	ABN/IBN location, characteristics and hours of operation	ABN: 315225N/1312622E, White/Green EV4.3sec, HO
2	LDI location and LGT Anemometer location and LGT	LDI: Nil Anemometer: RWY09: 180m from RWY 09 THR, LGTD RWY27: 150m from RWY 27 THR, LGTD
3	TWY edge and center line lighting	TWY edge and center line lights installed, see AD2.9
4	Secondary power supply/ switch-over time	Within 1sec: REDL, RENL, RTHL, WBAR, RCLL, Overrun area edge LGT, Stop bar LGT Within 15sec: Other LGT
5	Remarks	WDI LGT

RJFM AD 2.16 HELICOPTER LANDING AREA

Nil

RJFM AD 2.17 ATS AIRSPACE

Designation and lateral limits		Vertical limits (ft)	Airspace classification	ATS unit call sign Language	Remarks
1		2	3	4	6
MIYAZAKI CTR	Area within a radius of 5nm of MIYAZAKI ARP	3,000 or below	D	MIYAZAKI TWR En	
MIYAZAKI PCA	See attached chart		C	KAGOSHIMA APP (1) MIYAZAKI TWR (2) En	(1) Primary (2) Secondary
KAGOSHIMA ACA	See RJFK attached chart		E	KAGOSHIMA APP KAGOSHIMA RADAR KAGOSHIMA DEP En	
KAGOSHIMA TCA	See RJFK attached chart		E	KAGOSHIMA TCA En	

宮崎特別管制区
Miyazaki Positive Control Area

NAME	LATERAL LIMITS	UPPER LIMIT (AMSL)	UNIT PROVIDING SERVICE	REMARKS
		LOWER LIMIT (AMSL) M(ft)		
1	2	3	4	5
宮崎 MIYAZAKI	下記に示される区域 The area shown below		Primary Kagoshima APP 121.4 120.9 362.3 Secondary Miyazaki TWR 118.3 261.2	当該空域を飛行しようとする航空機は、鹿児島アプローチ又は宮崎タワーに連絡し、コールサイン、現在位置、高度及び意図を通報し指示を受けること。 Pilot of aircraft operating in this area shall contact Kagoshima Approach or Miyazaki Tower for ATC instructions giving informations on aircraft identification, positions, altitude and pilot's intentions.

RJFM AD 2.18 ATS COMMUNICATION FACILITIES

Service designation	Call sign	Frequency	Hours of operation	Remarks
1	2	3	4	5
APP/ASR	Kagoshima	121.4MHz(1)	2230 - 1230	(1)Primary APP Service provided by KAGOSHIMA APP
	Approach or	120.9MHz		
	Kagoshima Radar	362.3MHz(1)		
		261.2MHz		
		121.5MHz(E) 243.0MHz(E)		
DEP	Kagoshima Departure	120.1MHz(1)	2230 - 1230	
		121.4MHz		
		362.3MHz(1)		
		261.2MHz		
		121.5MHz(E) 243.0MHz(E)		
TWR	Miyazaki Tower	118.3MHz(1)	2230 - 1230	
		126.2MHz		
		123.6MHz		
		261.2MHz		
		121.5MHz(E) 243.0MHz(E)		
TCA	Kagoshima TCA	121.25MHz 256.1MHz	2330 - 1100	
GND	Miyazaki Ground	121.9MHz(1)	2230 - 1230	
ATIS	Miyazaki Airport	126.8MHz	2230 - 1230	

RJFM AD 2.19 RADIO NAVIGATION AND LANDING AIDS

Type of aid (VOR declination)	ID	Frequency	Hours of operation	Position of transmitting antenna coordinates	Elevation of DME transmitting antenna	Remarks
1	2	3	4	5	6	7
VOR (6°W/2013)	MZE	112.4MHz	H24	315243.42N/ 1312614.88E		Unusable : 200°-210° beyond 30nm BLW 7000ft. 210°-230° beyond 35nm BLW 7000ft. 230°-250° beyond 25nm BLW 7000ft.
DME	MZE	1158MHz CH-71X	H24	315243.42N/ 1312614.88E	54ft	Unusable: 016° between 3nm and 9nm at 6000ft. 033° between 7nm and 10nm at 9000ft. 339° between 2nm and 11nm at 10000ft.
ILS-LOC 27	IMZ	108.9MHz	2230 - 1230	315233.66N/ 1312558.68E		LOC:220m(722ft) away FM RWY 09 THR.BRG(MAG)272°
ILS-GP 27	-	329.3MHz	2230 - 1230	315244.23N/ 1312729.39E		GP:316m(1037ft) inside FM RWY 27 THR. 125m(410ft) N of RCL. Angle 3.0° HGT of ILS Ref 16.5m(54ft)
ILS-DME 27	IMZ	987MHz	2230 - 1230	315244.44N/ 1312729.01E	31ft	DME:320m(1050ft) inside FM RWY 27 THR.135m(443ft) N of RCL.
MSAS		1575.42MHz	H24			Transmitting antennas are satellite based

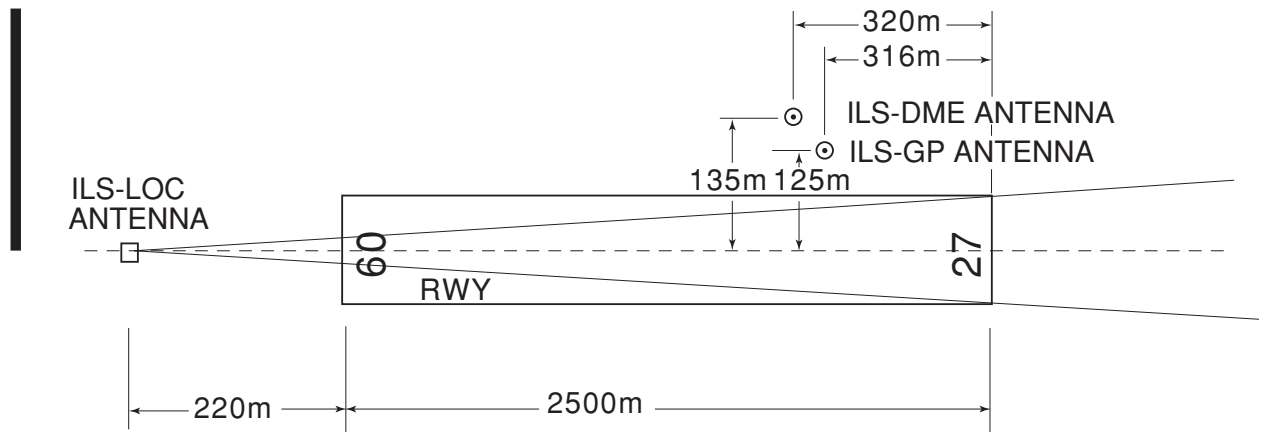

REMARKS:1.LOC beam BRG(MAG) 272°
2.HGT of ILS REF datum 16.5m(54ft)
3.GP Angle 3.0°
4.ELEV of ILS-DME 9.4m

RJFM AD 2.20 LOCAL TRAFFIC REGULATIONS

1. Airport regulations

Intersection departure

Separation for departure as in AD 1.1.6.3.2.2(2) will not be applied to aircraft departing from TWY S2 or N1. Aircraft requiring separation in AD 1.1.6.3.2.2(2) shall advise MIYAZAKI GROUND/TOWER accordingly.

2. Taxiing to and from stands

他の航空機又は障害物とのクリアランスの確保、及びジェットブラストによる影響の回避のため、スポット6とスポット10における自走アウトは、次の方式に従うこと。ただし、別途空港管理者の承認を受けた場合を除く。

- a) 自走アウトは、導入線直線部からの水平距離がスポット6にあつては25.5m、スポット10にあつては30.5mの区域内での旋回が可能な航空機に限ること。
- b) スポットにおける地上移動は、ブラストの影響が出ないことを確認の上行うこと。
- c) 自走アウトの旋回は、旋回線の起点までに開始すること。
- d) 旋回完了後は導入線に合し、導入線を導出線として利用すること。

In order to keep the clearance with other aircraft or obstacles and avoid jet blast damage, operators shall comply with the following power-out procedure on spot NR6 and NR10, although the case that approved by AD administration is excluded.

- a) Only the aircraft which is available to turn within the area whose horizontal distance from the straight part of the lead-in line is 25.5 meters on spot NR6 and 30.5 meters on spot NR10 is permitted to use this power-out procedure.
- b) Operators must confirm jet blast cause no damage when maneuvering on aircraft stands.
- c) Commence turning of the power-out procedure at or before the starting point of the turning line.
- d) After completing the turn, intercept the lead-in line and use the line as the lead-out line.

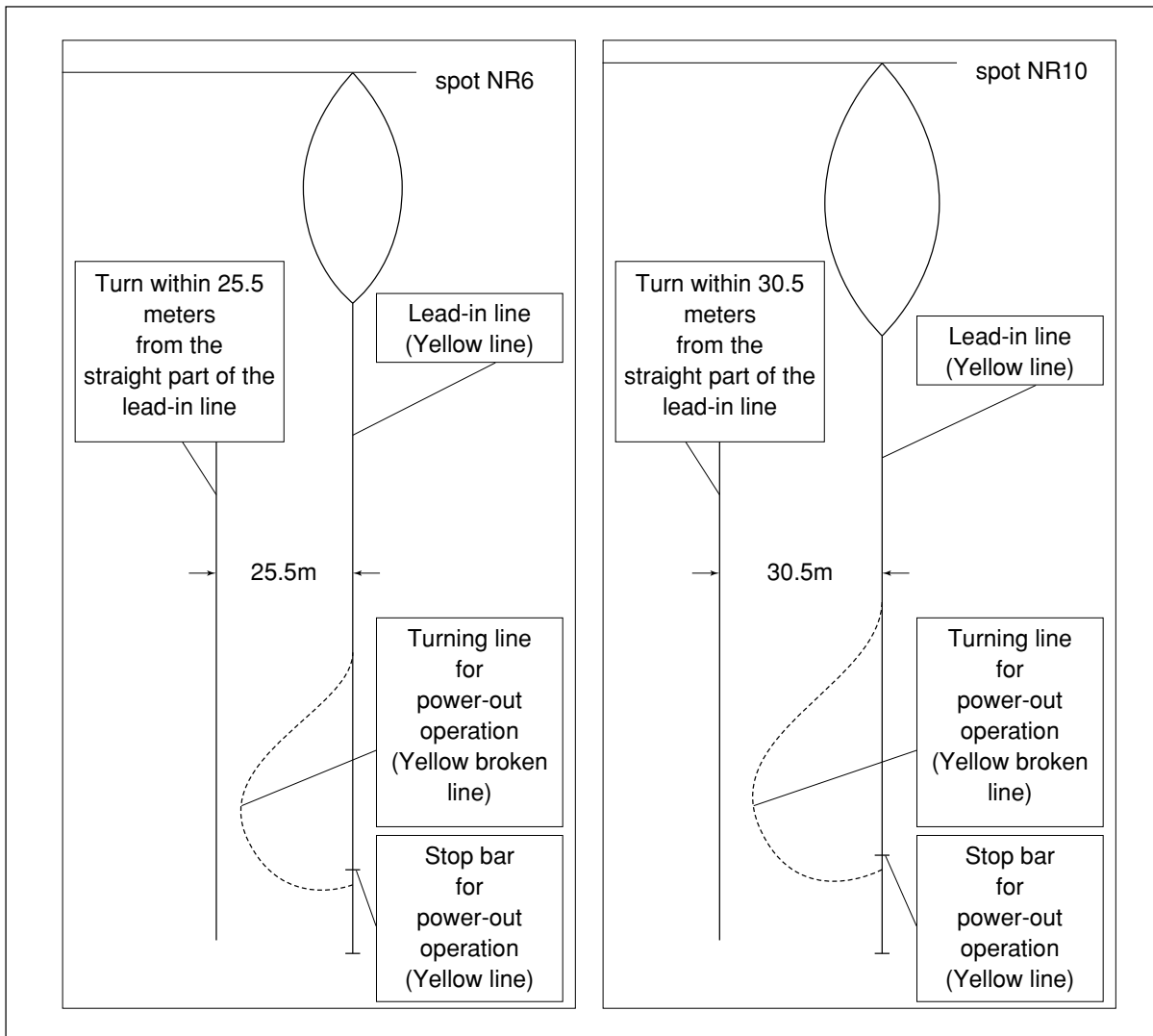

3. Parking area for small aircraft(General aviation)

Nil

4. Parking area for helicopters

Nil

5. Apron - taxiing during winter conditions

Nil

6. Taxiing - limitations

Nil

7. School and training flights - technical test flights - use of runways

Nil

8. Helicopter traffic - limitation

Nil

9. Removal of disabled aircraft from runways

Nil

RJFM AD 2.21 NOISE ABATEMENT PROCEDURES

<p>1. 騒音軽減運航方式 すべてのジェット機に対して、空港周辺における航空機騒音軽減のため、運航の安全に支障のない範囲で、以下の方式が適用される。ただし、これらの方式によることのできない航空機は実効的にこれらと同等と認められる代替方式を実施するものとする。</p> <p>(1) 離陸について（滑走路 27） 急上昇方式</p> <p>(2) 着陸について（滑走路 09） ディレイド・フラップ進入方式及び低フラップ角着陸方式</p> <p>(3) リバース・スラストについて なし</p> <p>2. 優先滑走路方式 なし</p> <p>3. 優先飛行経路 なし</p>	<p>1.Noise Abatement Operating Procedures For all jet aircraft, in order to reduce aircraft noise in the vicinity of airport, the following procedures shall be applied unless compliance of the procedures adversely affects the safety of aircraft operations. In case that the aircraft is unable to take these procedures, pilots should execute alternative procedures which are considered to be practically equivalent.</p> <p>1) For take-off from RWY27 Steepest Climb Procedure</p> <p>2) For landing to RWY09 Delayed Flap Approach Procedure and Reduced Flap Setting Procedure</p> <p>3) Reverse Thrust Nil</p> <p>2. Preferential Runways Procedures Nil</p> <p>3. Noise Preferential Routes Nil</p>
--	---

RJFM AD 2.22 FLIGHT PROCEDURES

1. TAKE OFF MINIMA

	RWY	ACFT CAT	REDL & RCLL		REDL or RCLL or RCL Marking		NIL (DAYTIME ONLY)	
			RVR	VIS	RVR	VIS	RVR	VIS
Multi-Engine ACFT with TKOF ALTN AP FILED	09	A,B,C,D	-	400m	-	400m	-	500m
	27	A,B,C,D	400m	400m	400m	400m	-	500m
OTHER	09	A,B,C,D	AVBL LDG MINIMA					
	27	A,B,C,D						

2. Lost Communication Procedures for Arrival Aircraft under Radar Navigational Guidance.

If radio communications with Kagoshima Approach/Radar are lost for 30 seconds, squawk Mode A/3 Code 7600 and;

- I
 - 1) Contact Miyazaki Tower.
 - 2) If unable, proceed in accordance with Visual Flight Rules.
 - 3) If unable, proceed to Miyazaki VOR at last assigned altitude or 4500 feet whichever is higher and execute Instrument Approach.
- II Procedures other than above will be issued when situation required.

RJFM AD 2.23 ADDITIONAL INFORMATION

Heli pad located on TWY S3 and S4 (See AD CHART)

RJFM AD 2.24 CHARTS RELATED TO AN AERODROME

- Aerodrome/Heliport Chart
- Standard Departure Chart-Instrument (SIIBA, SASIK)
- Standard Departure Chart-Instrument (MIYAZAKI-REVERSAL, JACKY)
- Standard Departure Chart-Instrument (KIZAK-RNAV)
- Standard Departure Chart-Instrument (KIRISHIMA-RNAV)
- Standard Arrival Chart-Instrument (OTOHIME)
- Standard Arrival Chart-Instrument (RYUGU-RNAV)
- Instrument Approach Chart-(ILS Z or LOC Z RWY27)
- Instrument Approach Chart-(ILS Y or LOC Y RWY27)
- Instrument Approach Chart-(VOR RWY27)
- Instrument Approach Chart-(RNAV(RNP) Z RWY09)
- Instrument Approach Chart-(RNAV(RNP) Y RWY09)
- Other Chart (Visual REP)
- Other Chart (LDG CHART)
- Other Chart (MVA CHART)

RJFM / MIYAZAKI

AD CHART

CHANGE: TWY S6 abolished. TWY renamed(S7 → S6, S8 → S7, SP7 → S7, SP7 → SP6).

MIYAZAKI AP

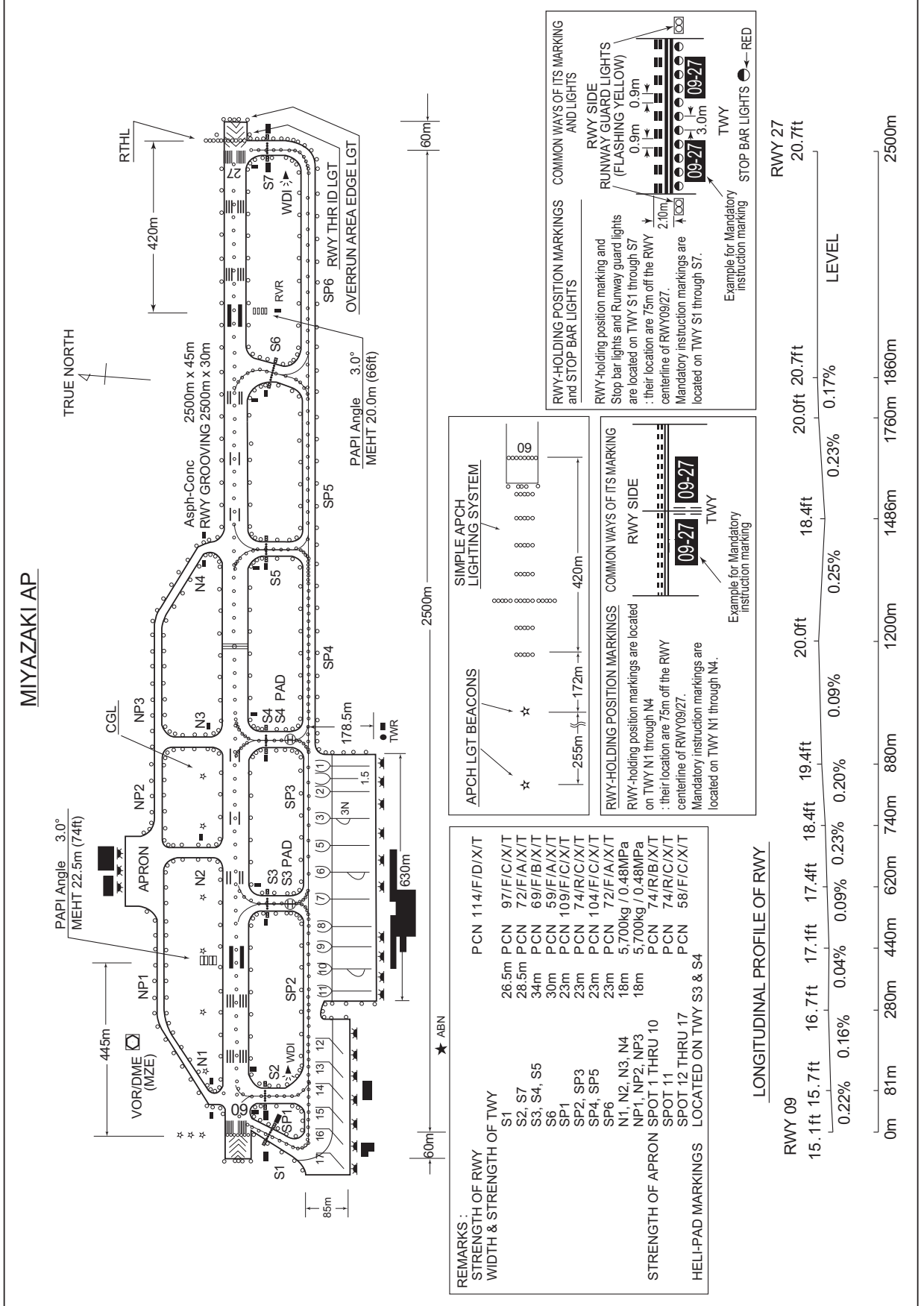

REMARKS:

STRENGTH OF RWY	PCN 114/F/D/X/I/T
WIDTH & STRENGTH OF TWY	S1 26.5m PCN 97/F/C/X/I/T S2, S7 28.5m PCN 72/F/A/X/I/T S3, S4, S5 34m PCN 69/F/B/X/I/T S6 30m PCN 59/F/A/X/I/T SP1 23m PCN 109/F/C/X/I/T SP2, SP3 23m PCN 74/R/C/X/I/T SP4, SP5 23m PCN 104/F/C/X/I/T SP6 23m PCN 72/F/A/X/I/T N1, N2, N3, N4 18m 5,700kg / 0.48MPa NP1, NP2, NP3 18m 5,700kg / 0.48MPa STRENGTH OF APRON SPOT 1 THRU 10 PCN 74/R/B/X/I/T SPOT 11 PCN 58/F/C/X/I/T SPOT 12 THRU 17 PCN 74/R/C/X/I/T HELI-PAD MARKINGS LOCATED ON TWY S3 & S4

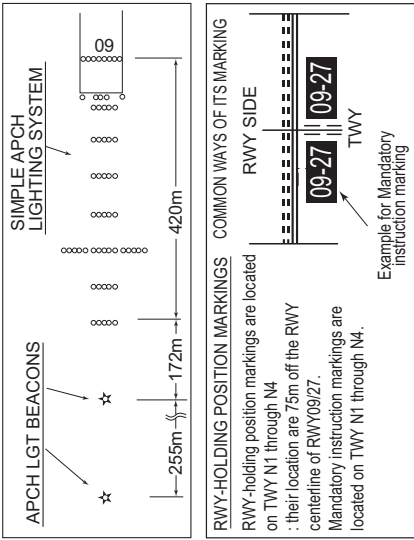

LONGITUDINAL PROFILE OF RWY

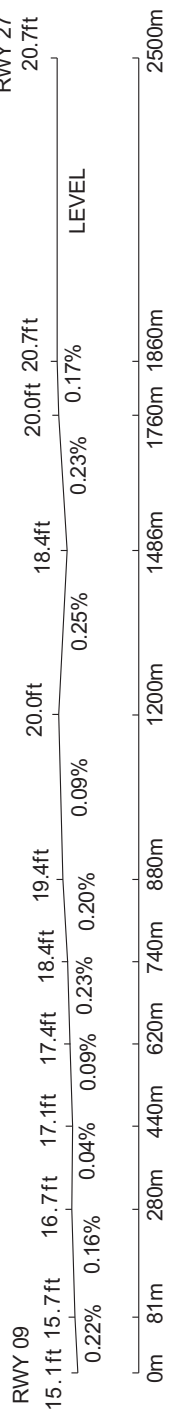

INTENTIONALLY LEFT BLANK

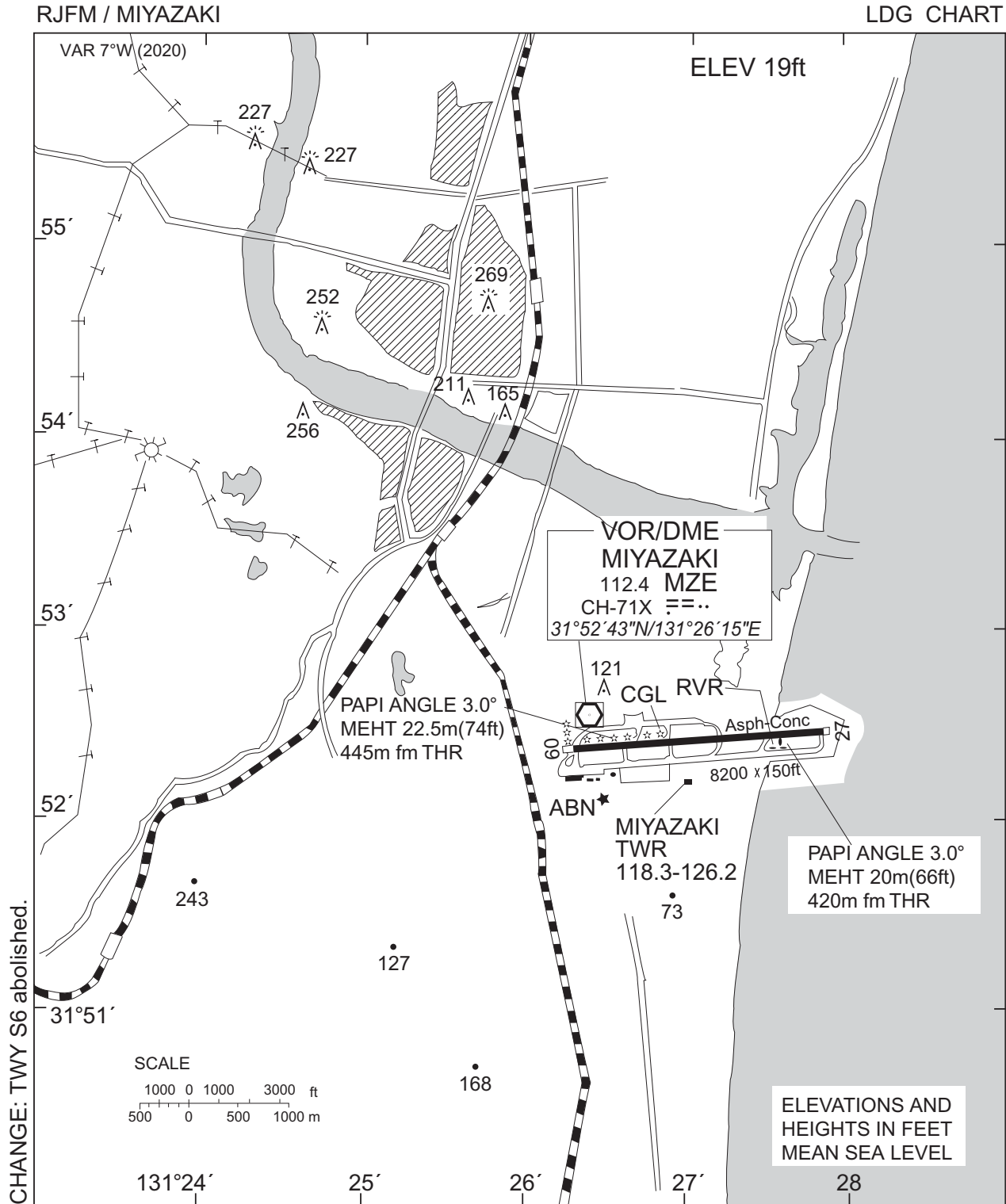

STANDARD DEPARTURE CHART - INSTRUMENT

RJFM / MIYAZAKI

RNAV SID and TRANSITION

KIZAK TWO DEPARTURE MADOG TRANSITION		RNAV1
Note 1) DME/DME/IRU or GNSS required. ※The aircraft equipped with only DME/DME/IRU must be able to update its position without delay at the starting point of take-off roll. 2) RADAR service required.	Critical DME	RWY27 TGE : 4.0NM to KIZAK - KIZAK
	DME GAP	RWY09 : DER - 4.0NM to KIZAK RWY27 : DER - 4.0NM to KIZAK
	Inappropriate Nav aids	See AD1.1.6.10.3. Inappropriate NAVAIDs for RNAV1

VAR 7° W(2016)

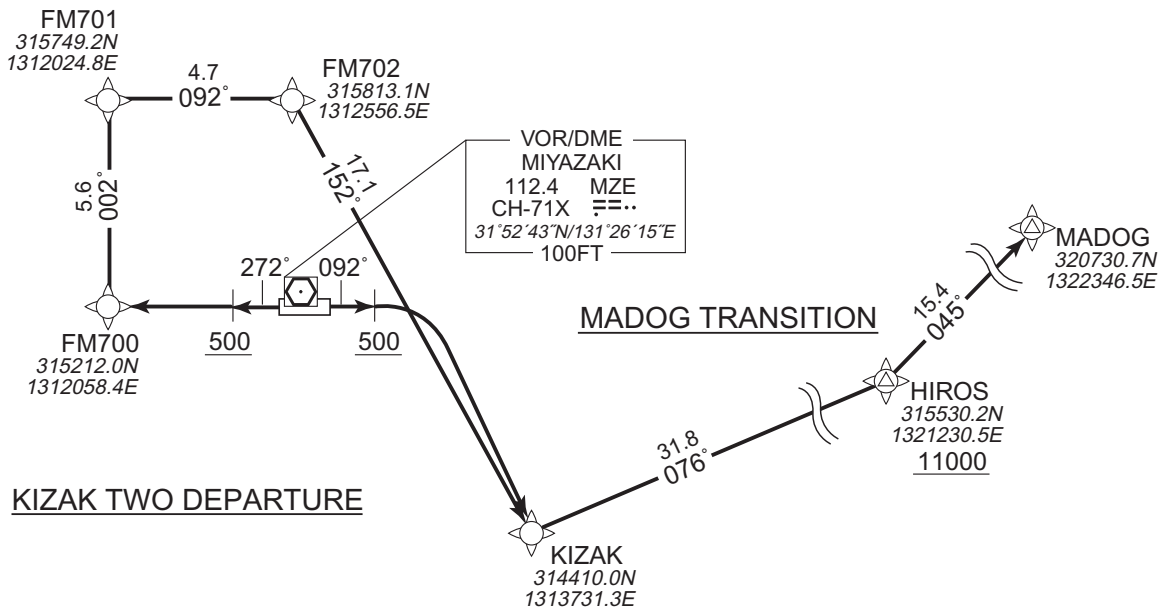

CHANGE : Critical DME

KIZAK TWO DEPARTURE

RWY09 : Climb on HDG092° at or above 500FT, direct to KIZAK.
 RWY27 : Climb on HDG272° at or above 500FT, direct to FM700, to FM701, to FM702, to KIZAK.
 NOTE RWY09: 5.0% climb gradient required up to 500FT.
 NOTE RWY27: 7.0% climb gradient required up to 900FT.

MADOG TRANSITION

From KIZAK, to HIROS at or above 11000FT, to MADOG.

STANDARD DEPARTURE CHART - INSTRUMENT

RJFM / MIYAZAKI

RNAV SID and TRANSITION

KIZAK TWO DEPARTURE

RWY09

Serial Number	Path Descriptor	Waypoint Identifier	Fly Over	Course °M(°T)	Magnetic Variation	Distance (NM)	Turn Direction	Altitude (FT)	Speed (KIAS)	Vertical Angle	Navigation Specification
001	VA	—	—	092 (085.2)	-6.8	—	—	+500	—	—	RNAV1
002	DF	KIZAK	—	—	-6.8	—	R	—	—	—	RNAV1

RWY27

Serial Number	Path Descriptor	Waypoint Identifier	Fly Over	Course °M(°T)	Magnetic Variation	Distance (NM)	Turn Direction	Altitude (FT)	Speed (KIAS)	Vertical Angle	Navigation Specification
001	VA	—	—	272 (265.2)	-6.8	—	—	+500	—	—	RNAV1
002	DF	FM700	—	—	-6.8	—	—	—	—	—	RNAV1
003	TF	FM701	—	002 (355.2)	-6.8	5.6	—	—	—	—	RNAV1
004	TF	FM702	—	092 (085.2)	-6.8	4.7	—	—	—	—	RNAV1
005	TF	KIZAK	—	152 (144.5)	-6.8	17.1	—	—	—	—	RNAV1

MADOG TRANSITION

Serial Number	Path Descriptor	Waypoint Identifier	Fly Over	Course °M(°T)	Magnetic Variation	Distance (NM)	Turn Direction	Altitude (FT)	Speed (KIAS)	Vertical Angle	Navigation Specification
001	IF	KIZAK	—	—	-6.8	—	—	—	—	—	RNAV1
002	TF	HIROS	—	076 (069.0)	-6.8	31.8	—	+11000	—	—	RNAV1
003	TF	MADOG	—	045 (038.4)	-6.8	15.4	—	—	—	—	RNAV1

INSTRUMENT APPROACH CHART

RJFM / MIYAZAKI

RNAV(RNP) Z RWY09

KAGOSHIMA APP 121.4 – 362.3 120.9 – 261.2	GNSS and RF required.	MIYAZAKI TOWER 118.3 – 126.2 123.6 – 261.2	RADAR AVBL ATIS 126.8
---	-----------------------	--	--------------------------

For uncompensated Baro-VNAV systems, procedure not authorized below -5°C/ above 45°C

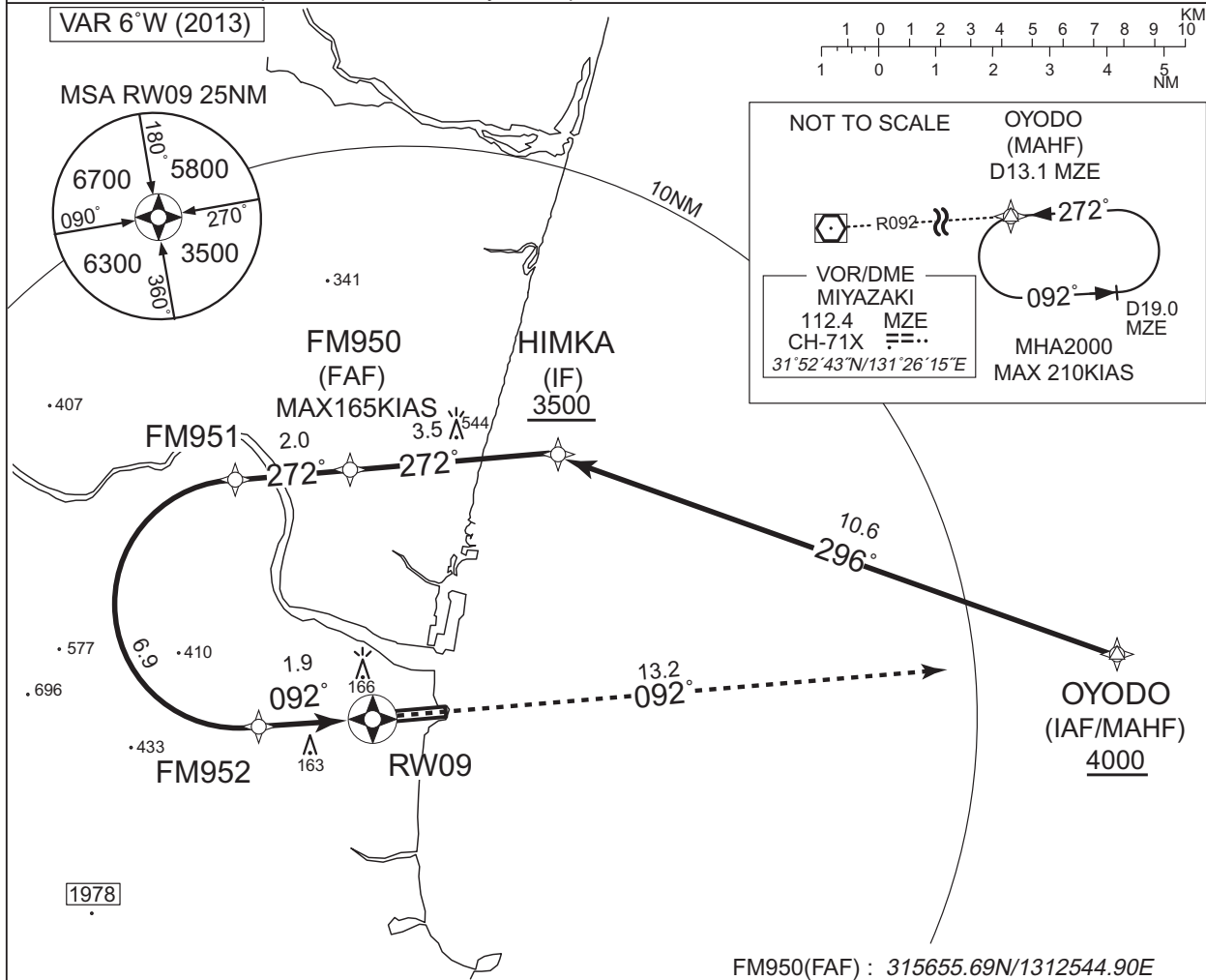

FM950(FAF) : 315655.69N/1312544.90E

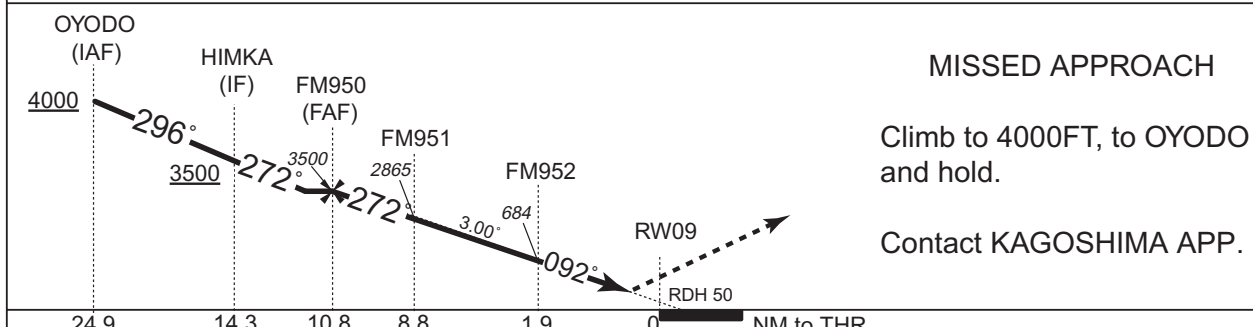

MISSED APPROACH

Climb to 4000FT, to OYODO and hold.

Contact KAGOSHIMA APP.

MINIMA	THR elev. 15	AD elev. 19
RNP 0.30		
CAT	DA(H)	CMV
A	—	—
B	—	—
C	327(312)	1400
D	—	1600

RNP AR
Special Authorization Required

INSTRUMENT APPROACH CHART

RJFM / MIYAZAKI

RNAV(RNP) Z RWY09

RNAV(RNP) Z RWY09

Coding Table

Serial Number	Path Descriptor	Waypoint Identifier	Fly Over	Course [°M(°T)]	Magnetic Variation	Distance (NM)	Turn Direction	Altitude (FT)	Speed (KIAS)	VPA/RDH (°/FT)	RNP Value
001	IF	OYODO	—	—	-6.5	—	—	+4000	—	—	—
002	TF	HIMKA	—	296 (289.7)	-6.5	10.6	—	+3500	—	—	1.0
003	TF	FM950	—	272 (265.2)	-6.5	3.5	—	3500	-165	—	1.0
004	TF	FM951	—	272 (265.2)	-6.5	2.0	—	2865	—	-3.00	0.3
005	RF Center: FMRF1 r=2.18NM	FM952	—	—	-6.5	6.9	L	684	—	-3.00	0.3
006	TF	RW09	Y	092 (085.1)	-6.5	1.9	—	65	—	-3.00/50	0.3
007	TF	OYODO	—	092 (085.1)	-6.5	13.2	—	4000	—	—	1.0

Waypoint Coordinates

Waypoint Identifier	Coordinates	RF Arc Center Identifier	Coordinates
HIMKA	315713.28N/1312950.79E	FMRF1	315435.02N/1312337.63E
FM950	315655.69N/1312544.90E		
FM951	315645.60N/1312324.68E		
FM952	315224.44N/1312350.57E		
RW09	315234.26N/1312607.02E		
OYODO	315340.52N/1314134.32E		

INSTRUMENT APPROACH CHART

RJFM / MIYAZAKI

RNAV(RNP) Y RWY09

KAGOSHIMA APP 121.4 – 362.3 120.9 – 261.2	GNSS and RF required.	MIYAZAKI TOWER 118.3 – 126.2 123.6 – 261.2	RADAR AVBL ATIS 126.8
---	-----------------------	--	--------------------------

For uncompensated Baro-VNAV systems, procedure not authorized below -5°C/ above 45°C

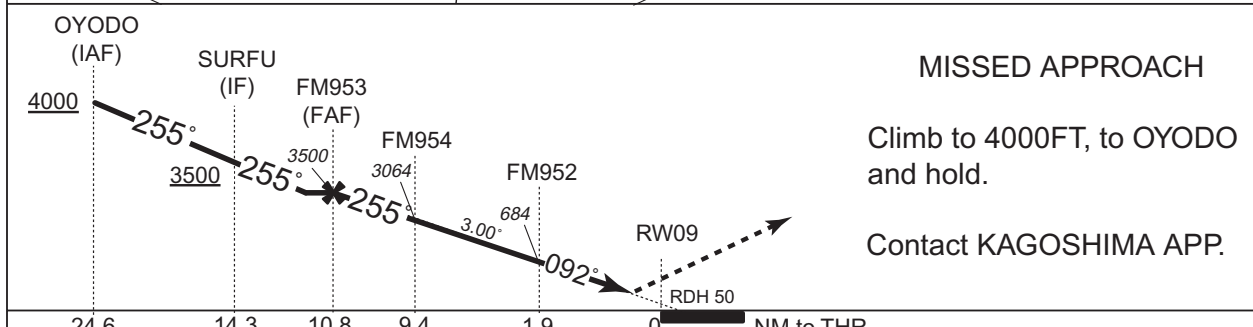
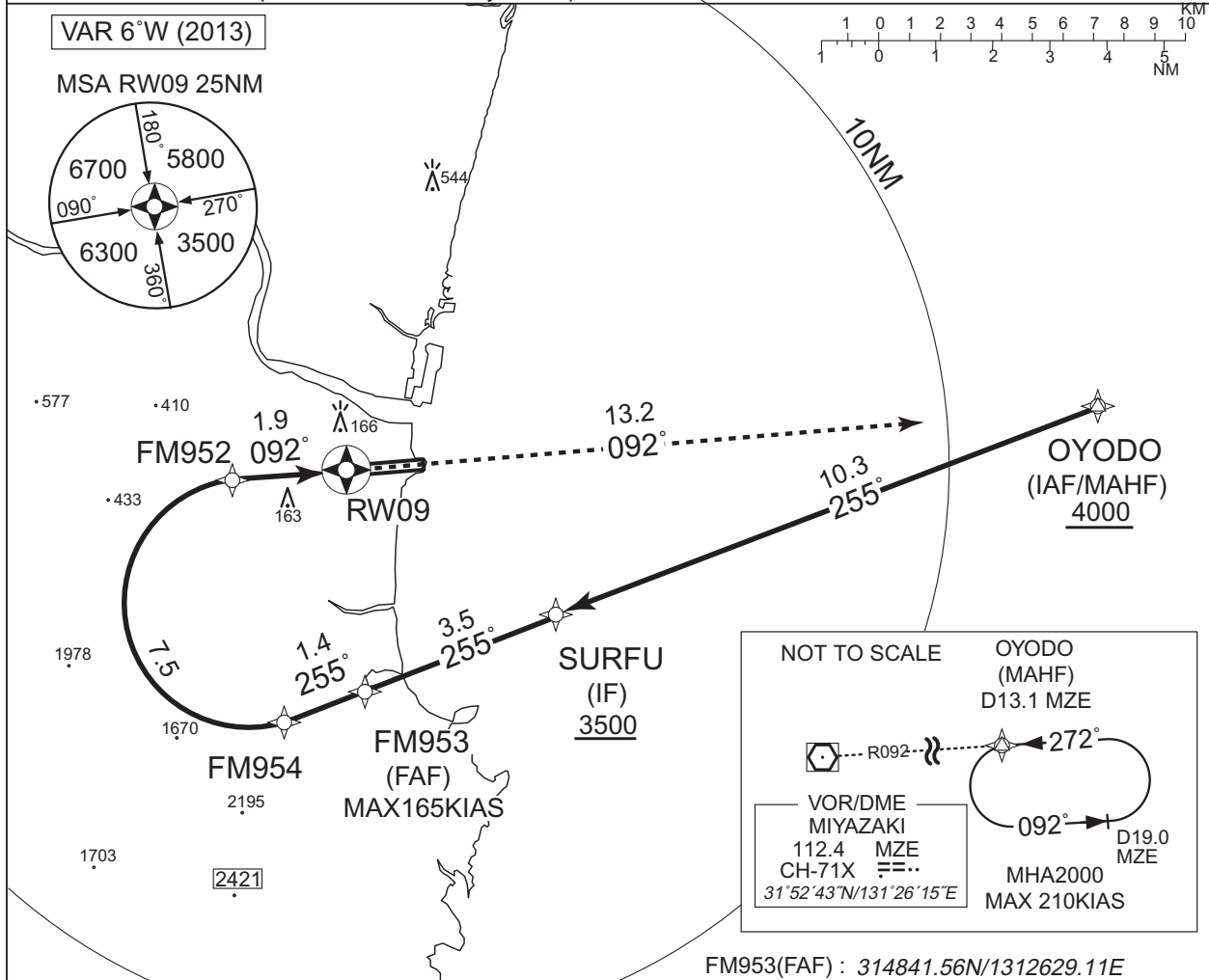

MINIMA	THR elev. 15	AD elev. 19
CAT	RNP 0.30	
A	—	—
B	—	—
C	327(312)	1400
D	—	1600

RNP AR
Special Authorization Required

INSTRUMENT APPROACH CHART

RJFM / MIYAZAKI

RNAV(RNP) Y RWY09

RNAV(RNP) Y RWY09

Coding Table

Serial Number	Path Descriptor	Waypoint Identifier	Fly Over	Course [°M(°T)]	Magnetic Variation	Distance (NM)	Turn Direction	Altitude (FT)	Speed (KIAS)	VPA/RDH (°/FT)	RNP Value
001	IF	OYODO	—	—	-6.5	—	—	+4000	—	—	—
002	TF	SURFU	—	255 (248.8)	-6.5	10.3	—	+3500	—	—	1.0
003	TF	FM953	—	255 (248.7)	-6.5	3.5	—	3500	-165	—	1.0
004	TF	FM954	—	255 (248.7)	-6.5	1.4	—	3064	—	-3.00	0.3
005	RF Center: FMRF2 r=2.18NM	FM952	—	—	-6.5	7.5	R	684	—	-3.00	0.3
006	TF	RW09	Y	092 (085.1)	-6.5	1.9	—	65	—	-3.00/50	0.3
007	TF	OYODO	—	092 (085.1)	-6.5	13.2	—	4000	—	—	1.0

Waypoint Coordinates

Waypoint Identifier	Coordinates	RF Arc Center Identifier	Coordinates
SURFU	314957.66N/1313018.83E	FMRF2	315013.85N/1312403.51E
FM953	314841.56N/1312629.11E		
FM954	314811.70N/1312459.11E		
FM952	315224.44N/1312350.57E		
RW09	315234.26N/1312607.02E		
OYODO	315340.52N/1314134.32E		

RJFM / MIYAZAKI

Minimum Vectoring Altitude CHART

VAR 7°W (2017)

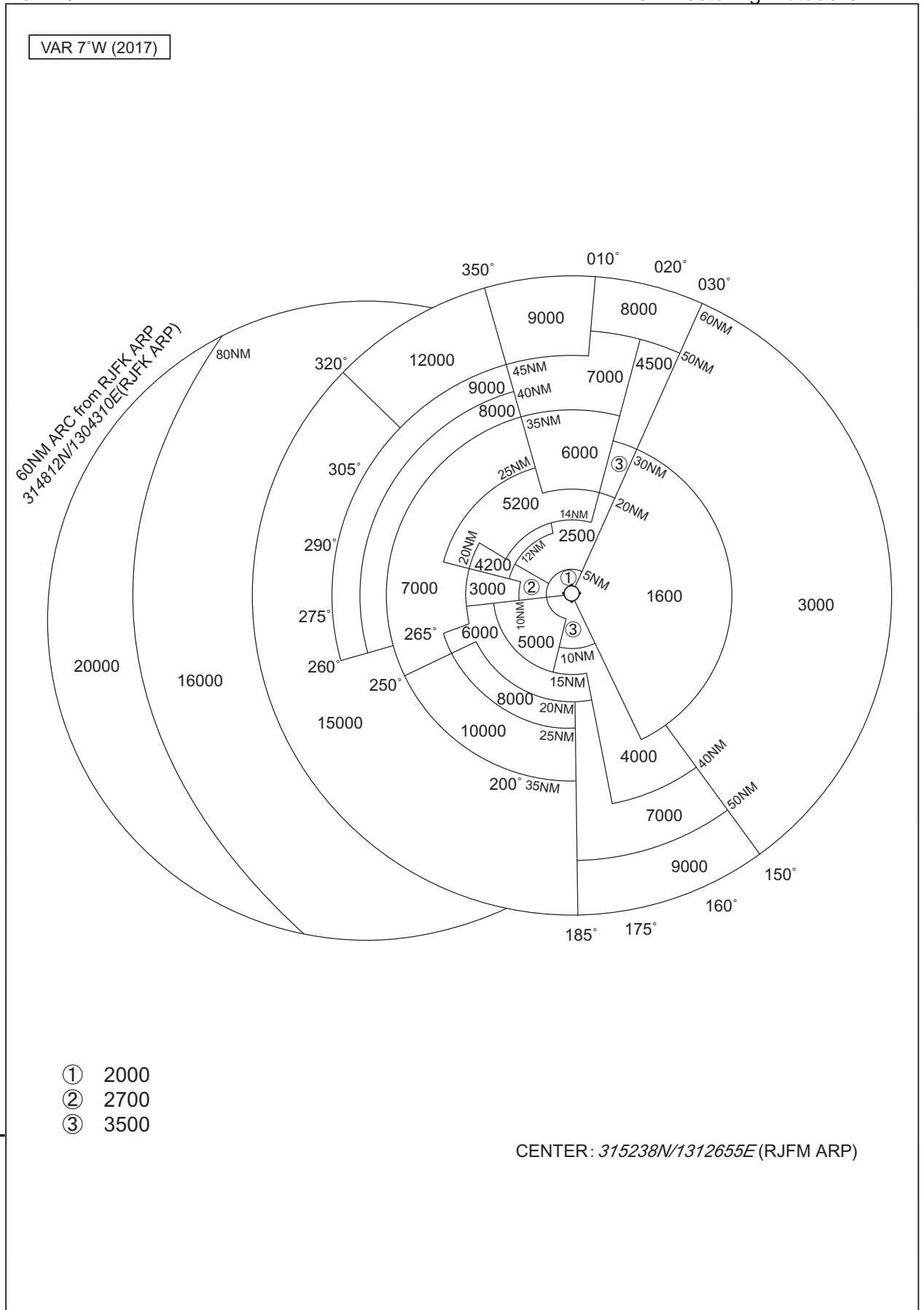

CHANGE : Update

STANDARD DEPARTURE CHART - INSTRUMENT

RJFM/ MIYAZAKI

RNAV SID

KIRISHIMA ONE DEPARTURE		RNAV 1
Note 1) DME/DME/IRU or GNSS required. ※The aircraft equipped with only DME/DME/IRU must be able to update its position without delay at the starting point of take-off roll. 2) RADAR service required.	Critical DME	RWY09 : NHT : 2NM FM DER — 2NM to FM900 RWY27 : NHT : 5NM to FM703 — FM703
	DME GAP	RWY09 : DER — 2NM FM DER RWY27 : DER — 5NM to FM703
	Inappropriate Nav aids	See AD 1.1.6.10.3. Inappropriate NAVAIDS for RNAV1

VAR 7°W (2020)

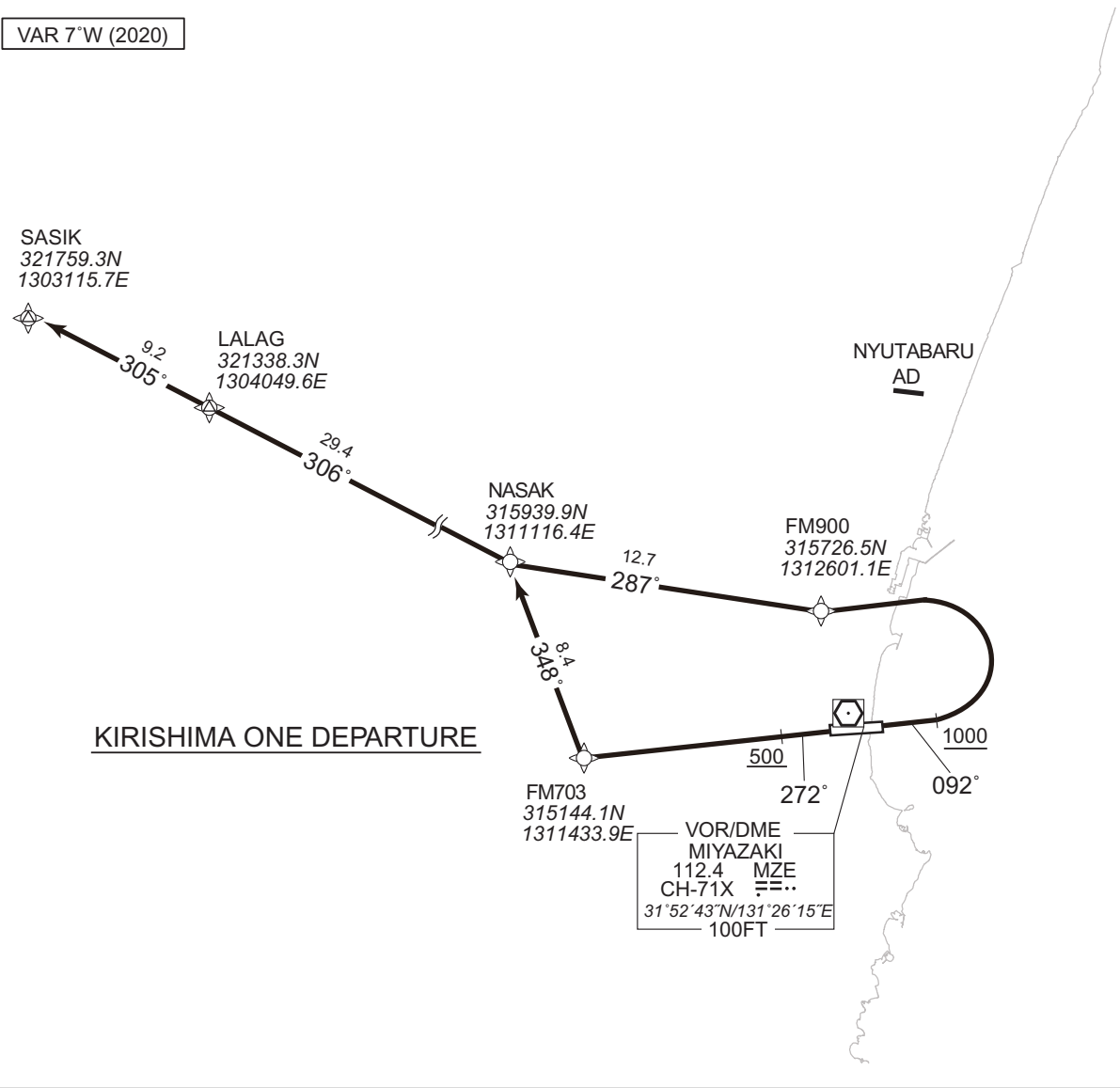

KIRISHIMA ONE DEPARTURE

RWY09 : Climb on HDG092° at or above 1000FT, turn left direct to FM900, to NASAK, to LALAG, to SASIK.

RWY27 : Climb on HDG272° at or above 500FT, direct to FM703, to NASAK, to LALAG, to SASIK.

Note RWY09 : 5.0% climb gradient required up to 1000FT.

RWY27 : 5.0% climb gradient required up to 5000FT.

OBST ALT 152FT located at 0.7NM 276° FM end of RWY27.

CHANGE : New PROC.

STANDARD DEPARTURE CHART - INSTRUMENT

RJFM / MIYAZAKI

RNAV SID

KIRISHIMA ONE DEPARTURE

RWY09

Serial Number	Path Descriptor	Waypoint Identifier	Fly Over	Course °M(°T)	Magnetic Variation	Distance (NM)	Turn Direction	Altitude (FT)	Speed (KIAS)	Vertical Angle	Navigation Specification
001	VA	-	-	092 (085.2)	-7.2	-	-	+1000	-	-	RNAV1
002	DF	FM900	-	-	-7.2	-	L	-	-	-	RNAV1
003	TF	NASAK	-	287 (280.1)	-7.2	12.7	-	-	-	-	RNAV1
004	TF	LALAG	-	306 (298.6)	-7.2	29.4	-	-	-	-	RNAV1
005	TF	SASIK	-	305 (298.3)	-7.2	9.2	-	-	-	-	RNAV1

RWY27

Serial Number	Path Descriptor	Waypoint Identifier	Fly Over	Course °M(°T)	Magnetic Variation	Distance (NM)	Turn Direction	Altitude (FT)	Speed (KIAS)	Vertical Angle	Navigation Specification
001	VA	-	-	272 (265.2)	-7.2	-	-	+500	-	-	RNAV1
002	DF	FM703	-	-	-7.2	-	-	-	-	-	RNAV1
003	TF	NASAK	-	348 (340.6)	-7.2	8.4	-	-	-	-	RNAV1
004	TF	LALAG	-	306 (298.6)	-7.2	29.4	-	-	-	-	RNAV1
005	TF	SASIK	-	305 (298.3)	-7.2	9.2	-	-	-	-	RNAV1

CHANGE : New PROC.

STANDARD DEPARTURE CHART - INSTRUMENT

RJFM / MIYAZAKI

SID

SIIBA ONE DEPARTURE

RWY27 : Climb via MZE R275 to 6.0DME, turn right HDG060° to intercept and proceed via MZE R015 to SIIBA.

Cross MZE R345 at or above 6000FT.

RWY09 : Climb via MZE R091 to 8.0DME, turn left HDG330° to intercept and proceed via MZE R015 to SIIBA.

Cross MZE R040 at or above 6000FT.

Note RWY27 : 5.0% climb gradient required up to 5000FT.

OBST ALT 1637FT located at 8.3NM 285° FM end of RWY27.

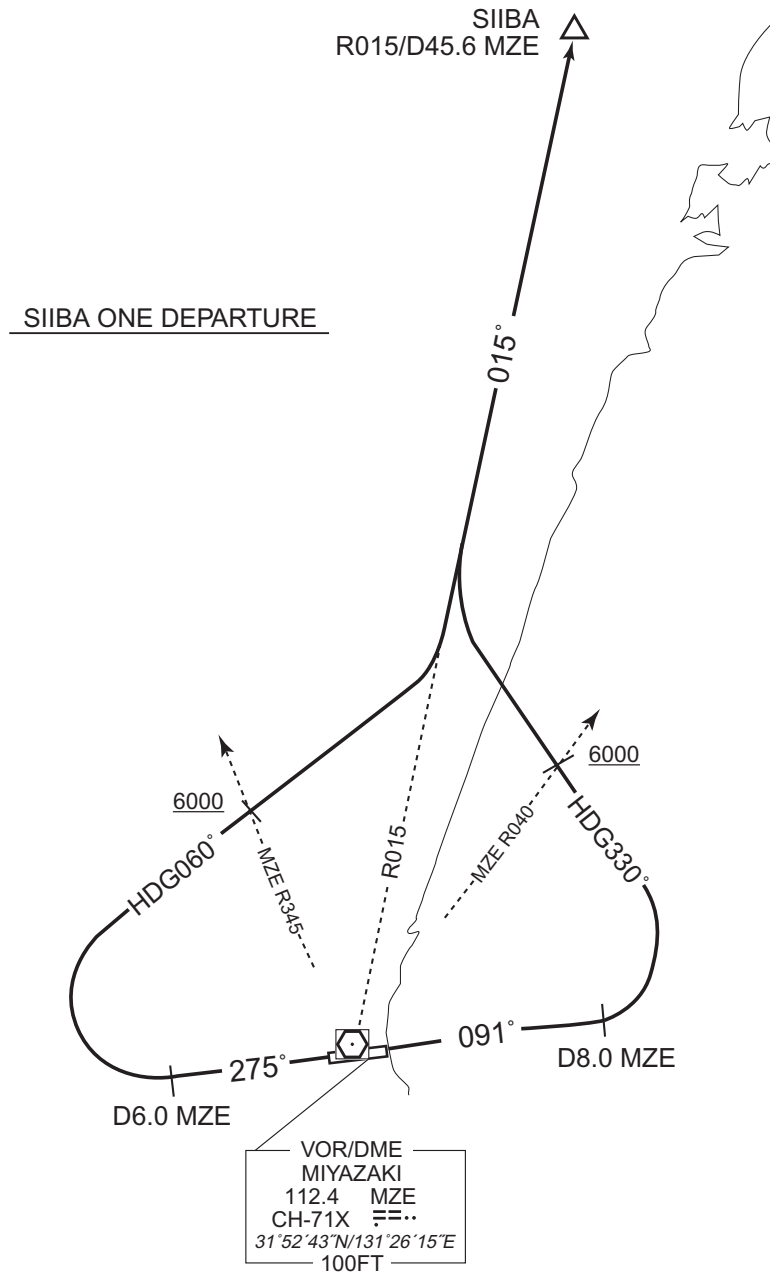

STANDARD DEPARTURE CHART - INSTRUMENT

RJFM / MIYAZAKI

SID

SASIK THREE DEPARTURE

RWY27 : Climb via MZE R275 to 10.0DME, turn right HDG350°...

RWY09 : Climb RWY HDG to 1000FT, turn left HDG275°...
...to intercept and proceed via MZE R305 to SASIK via TORIK and LALAG.
Cross TORIK at assigned altitude.

Note RWY27 : 5.0% climb gradient required up to 5000FT.
OBST ALT 152FT located at 0.7NM 276° FM end of RWY27.
RWY09 : 5.0% climb gradient required up to 1000FT.

CHANGE : PROC. OBST.

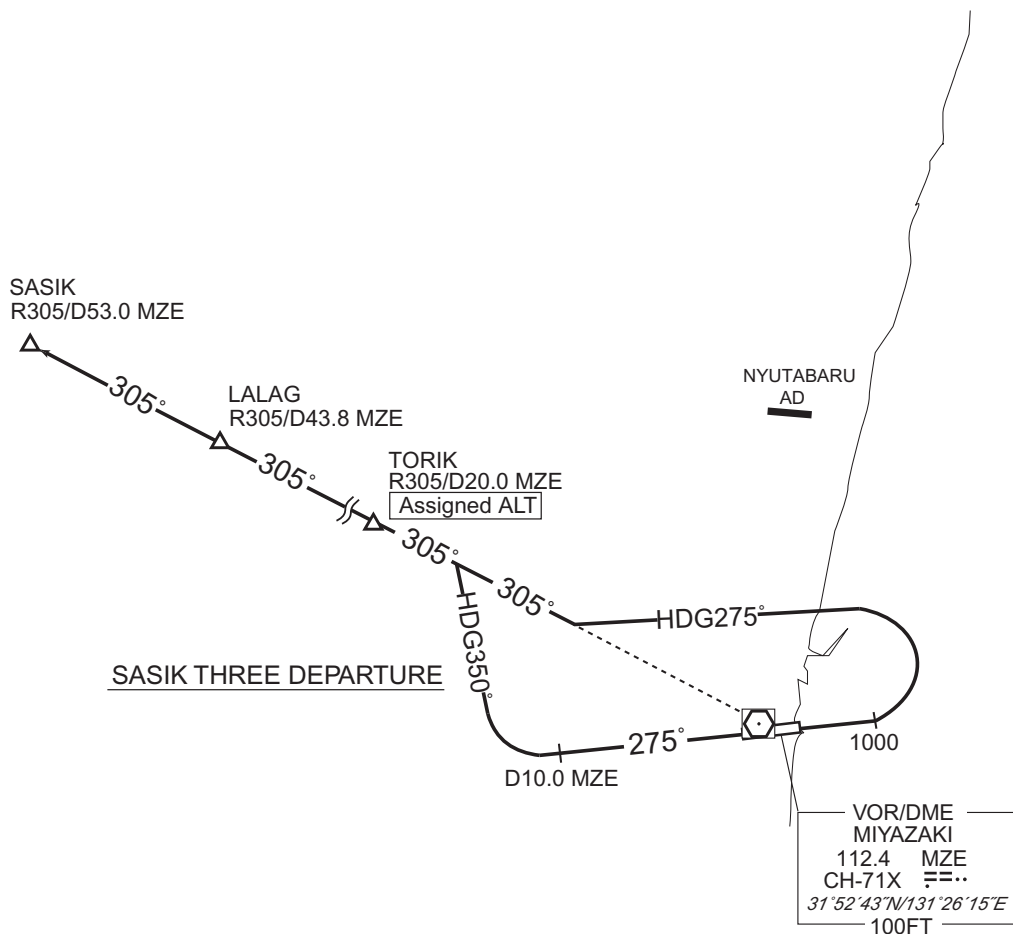

STANDARD DEPARTURE CHART - INSTRUMENT

RJFM / MIYAZAKI

SID

MIYAZAKI REVERSAL ONE DEPARTURE

RWY 27 : Climb via MZE R275 to 10.0DME, turn right,...

RWY 09 : Turn right, climb via MZE R138 to 12.0DME, turn left, ...
...direct to MZE VOR/DME.

Note RWY27 : 5.0% climb gradient required up to 5000FT.
OBST ALT 152FT located at 0.7NM 276° FM end of RWY27.

JACKY ONE DEPARTURE

RWY 27 : Climb RWY HDG to MZE 2.0DME, turn right, direct to MZE VOR/DME,...

RWY 09 : Turn right, climb...
...via MZE R138 to JACKY.

Note RWY27 : 5.0% climb gradient required up to 500FT.
OBST ALT 395FT located at 3.1NM 281° FM end of RWY27.

CHANGE : OBST(MIYAZAKI REVERSAL ONE DEPARTURE).

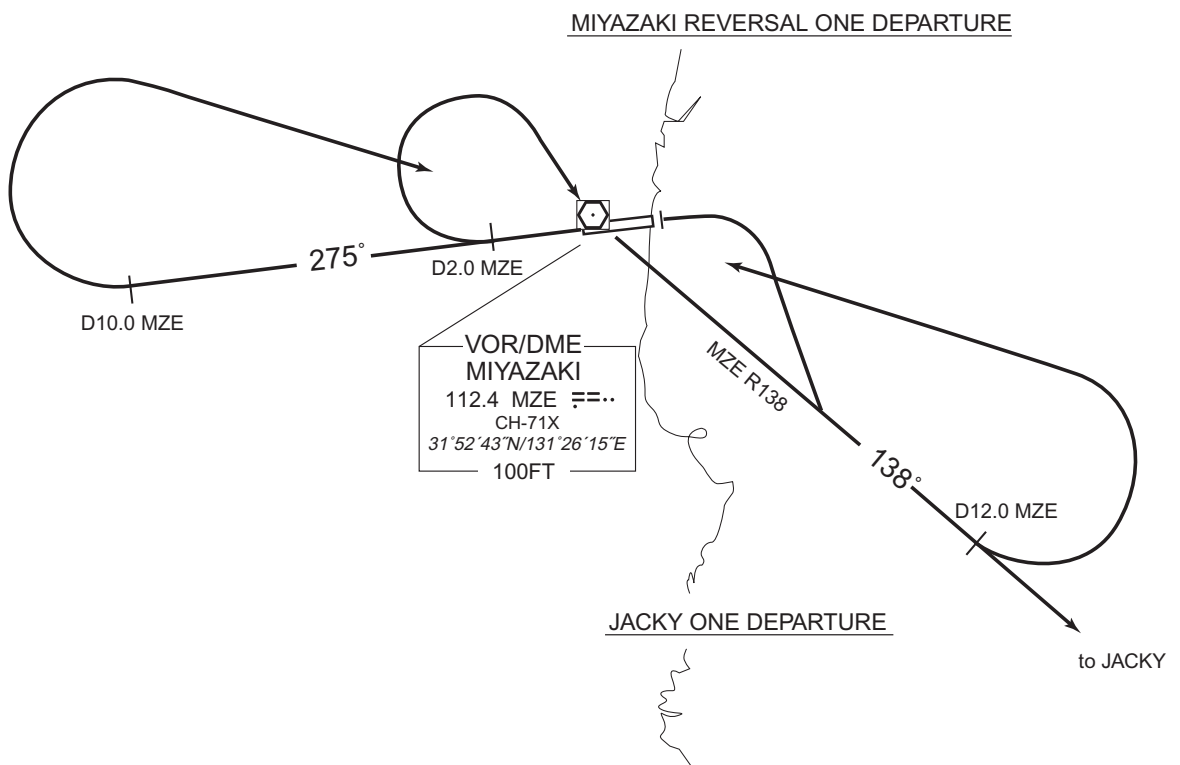

STANDARD ARRIVAL CHART - INSTRUMENT

RJFM / MIYAZAKI

STAR

OTOHIME ARRIVAL

From over RYUGU, via SUC R236 to CHAGA, via MZE R092 to OYODO.
Cross CHAGA at or above 5000FT, cross OYODO at or above 2000FT.

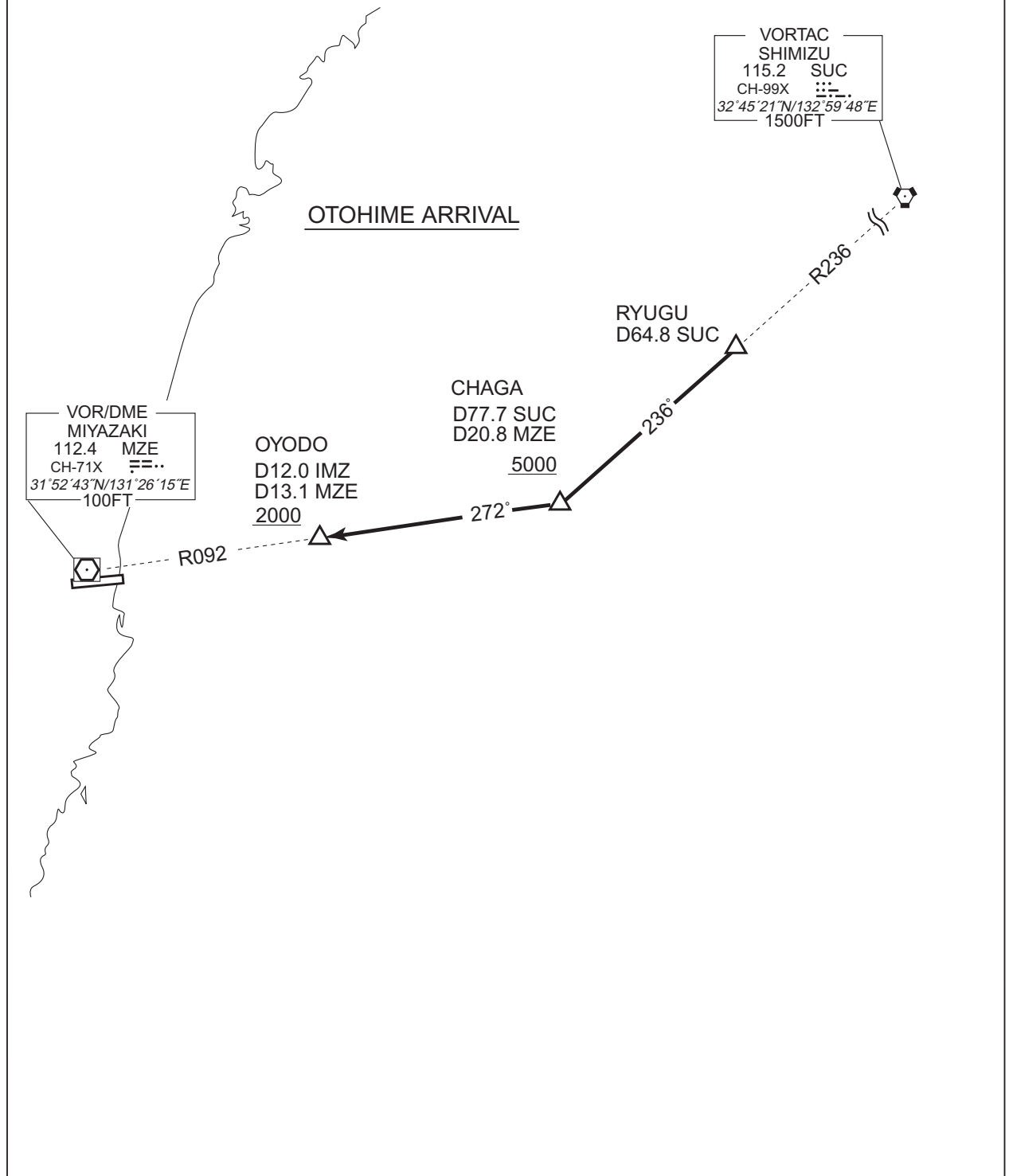

STANDARD ARRIVAL CHART - INSTRUMENT

RJFM / MIYAZAKI

RNAV STAR

RYUGU ARRIVAL

RNAV1

Note 1) DME/DME/IRU or GNSS required.
2) RADAR service required.

VAR 7°W (2016)

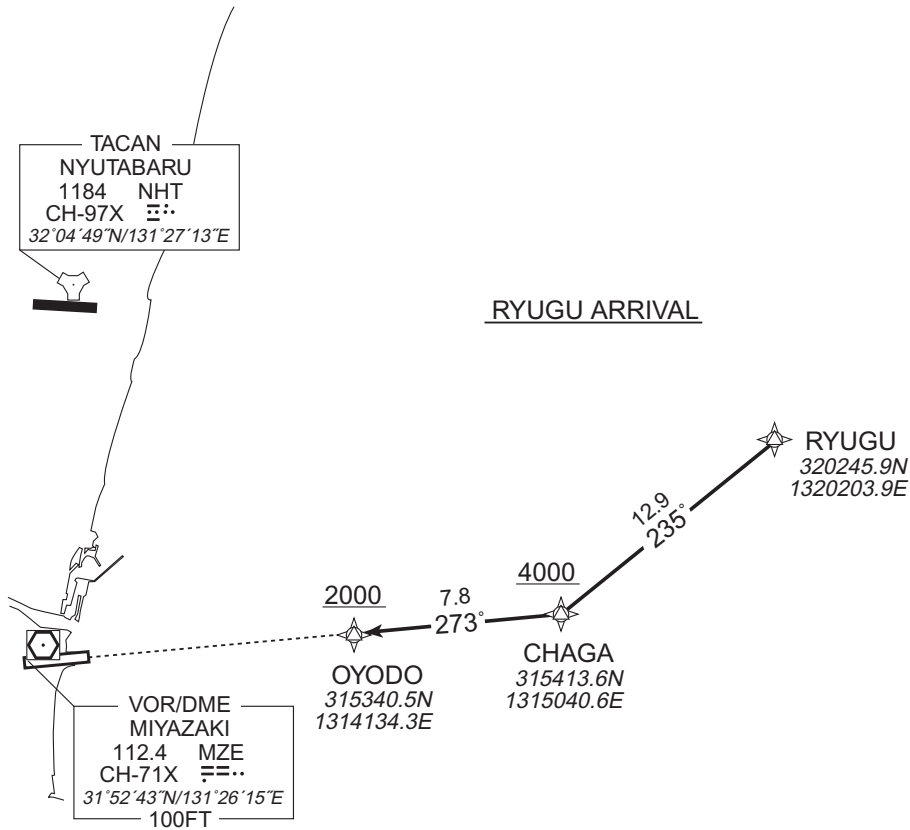

RYUGU ARRIVAL

From RYUGU, to CHAGA at or above 4000FT, to OYODO at or above 2000FT.

Critical DME	-
DME GAP	-
Inappropriate Nav aids	See AD1.1.6.10.3. Inappropriate NAVAIDs for RNAV1

CHANGE : Critical DME

Serial Number	Path Descriptor	Waypoint Identifier	Fly Over	Course °M(°T)	Magnetic Variation	Distance (NM)	Turn Direction	Altitude (FT)	Speed (KIAS)	Vertical Angle	Navigation Specification
001	IF	RYUGU	-	-	-6.8	-	-	-	-	-	RNAV1
002	TF	CHAGA	-	235 (228.6)	-6.8	12.9	-	+4000	-	-	RNAV1
003	TF	OYODO	-	273 (266.0)	-6.8	7.8	-	+2000	-	-	RNAV1

INSTRUMENT APPROACH CHART

RJFM / MIYAZAKI ILS Z or LOC Z RWY27

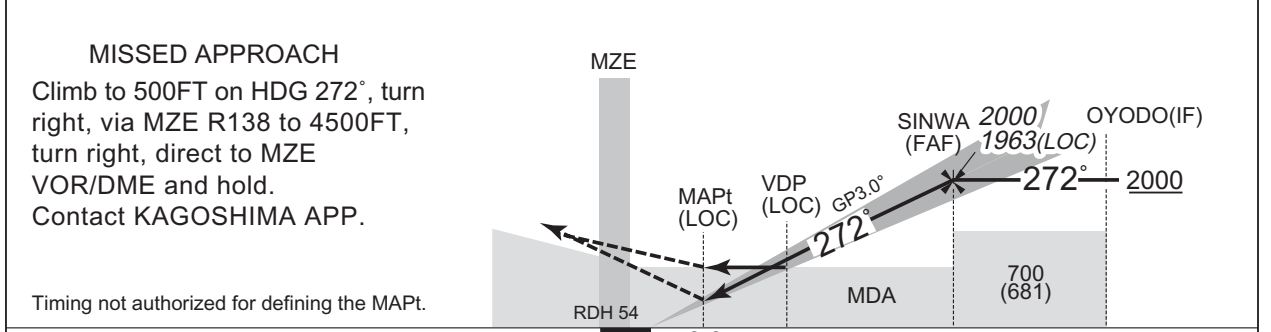
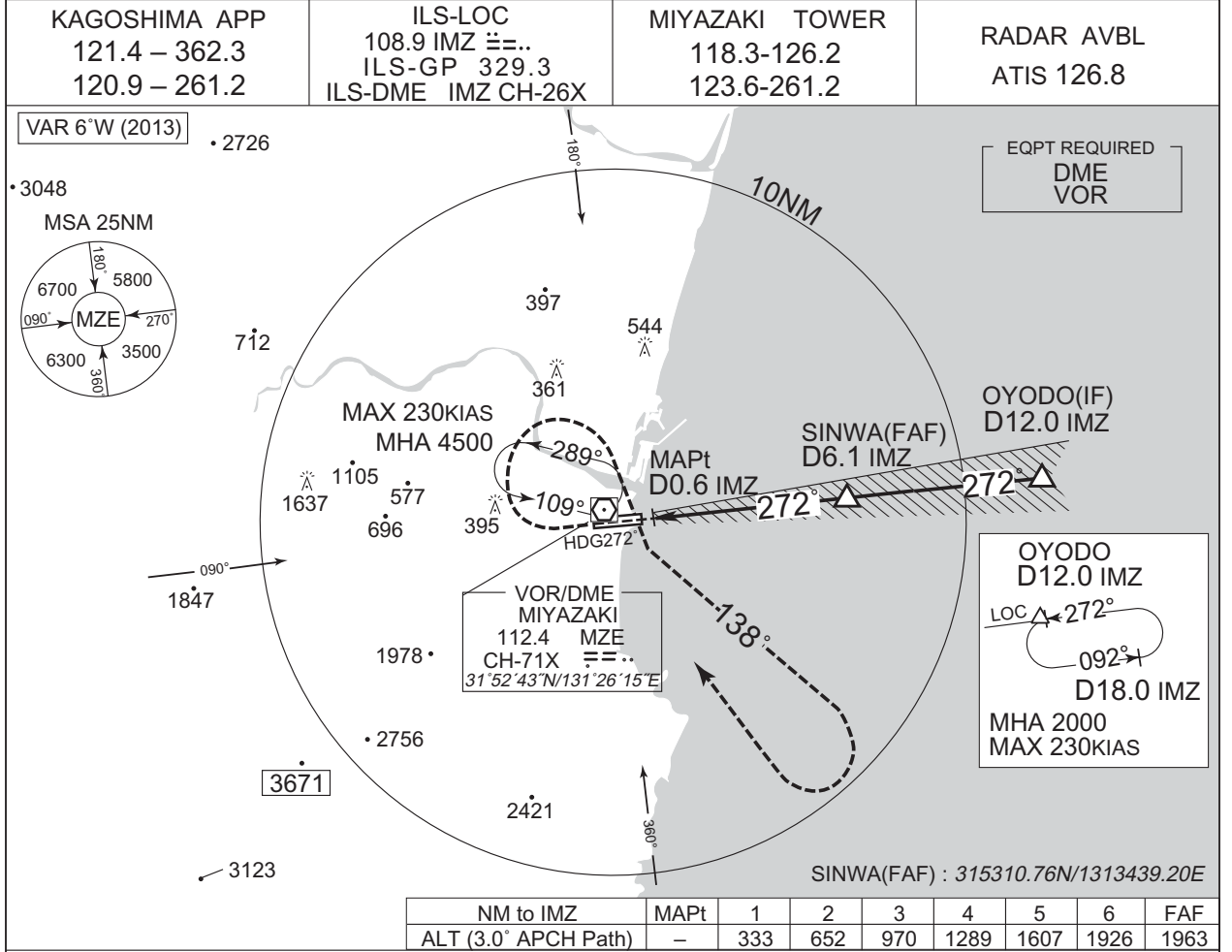

DME to IMZ	0.2	0.6	0.8	6.1	12.0
NM to THR	0	0.5	0.6	5.9	11.9

Missed APCH climb gradient MNM 4.0%

MINIMA	THR elev. 21	AD elev. 19			
CAT	CAT I		LOC		CIRCLING
	DA(H)	RVR/CMV	MDA(H)	RVR/CMV	MDA(H) VIS
A	221 (200)	1000	270 (251)	1500	520 (501) 1600
B				1600	650 (631) 2400
C				1800	3200
D					

MINIMA with Missed APCH climb gradient of 2.5% are not established.

INSTRUMENT APPROACH CHART

RJFM / MIYAZAKI

ILS Y or LOC Y RWY27

KAGOSHIMA APP 121.4 – 362.3 120.9 – 261.2	ILS-LOC 108.9 IMZ ≡≡.. ILS-GP 329.3 ILS-DME IMZ CH-26X	MIYAZAKI TOWER 118.3 - 126.2 123.6 - 261.2	RADAR AVBL ATIS 126.8
---	---	--	------------------------------

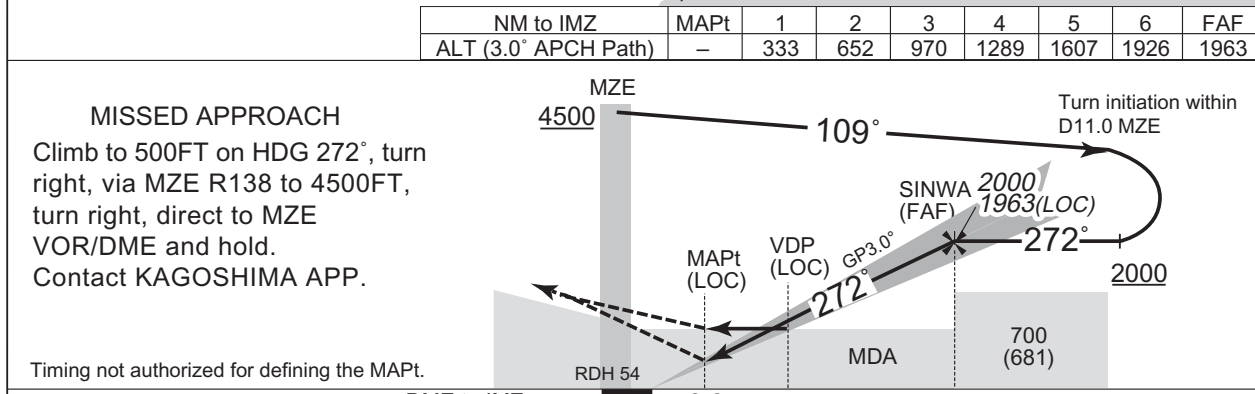
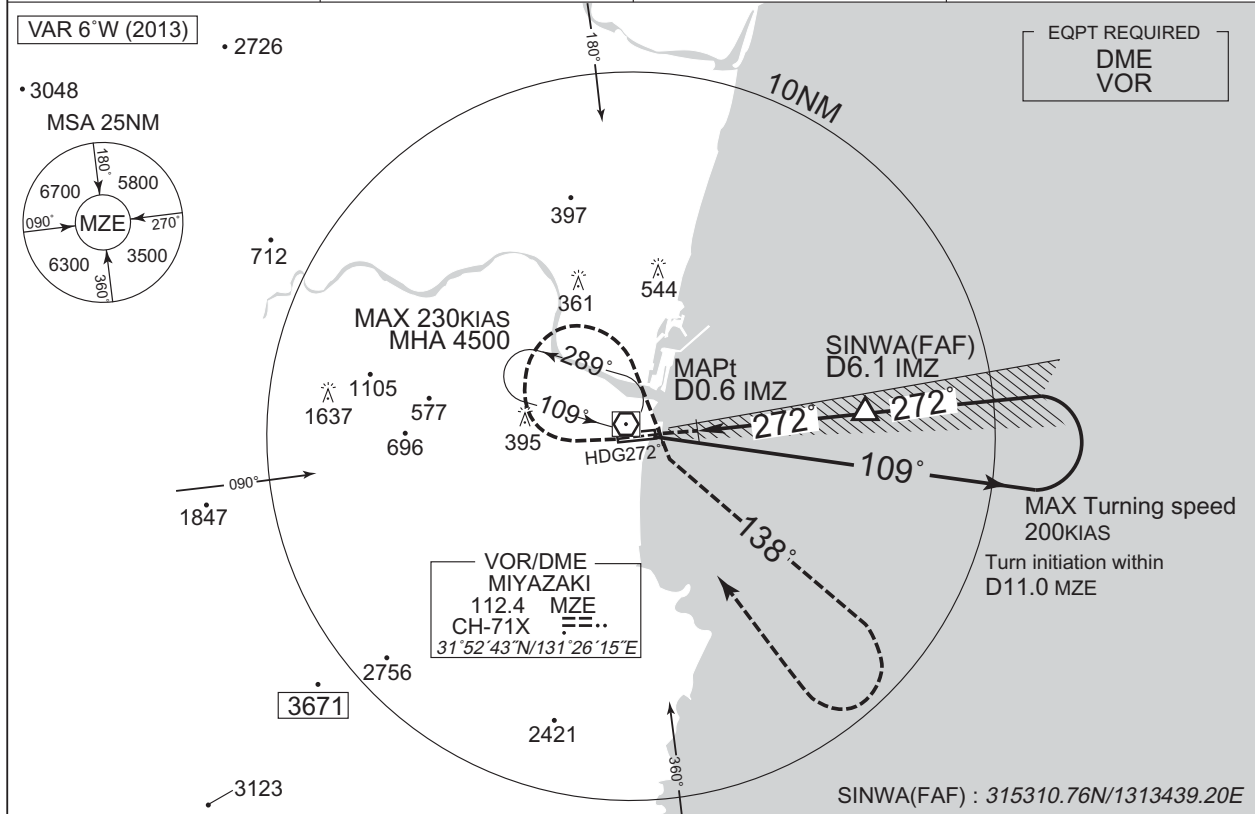

DME to IMZ	0.2	0.6	0.8	6.1
NM to THR	0	0.5	0.6	5.9

Missed APCH climb gradient MNM 4.0%

MINIMA	THR elev. 21		AD elev. 19			
CAT	CAT I		LOC		CIRCLING	
	DA(H)	RVR/CMV	MDA(H)	RVR/CMV	MDA(H)	VIS
A	221 (200)	1000	270 (251)	1500	520 (501)	1600
B				1600		
C				1800	650 (631)	2400
D				1800		

MINIMA with Missed APCH climb gradient of 2.5% are not established.

INSTRUMENT APPROACH CHART

RJFM / MIYAZAKI

VOR RWY27

KAGOSHIMA APP 121.4 – 362.3 120.9 – 261.2	MIYAZAKI VOR/DME 112.4 MZE CH-71X ≡≡.. 31°52'43"N/131°26'15"E	MIYAZAKI TOWER 118.3 - 126.2 123.6 - 261.2	RADAR AVBL ATIS 126.8
---	--	--	------------------------------

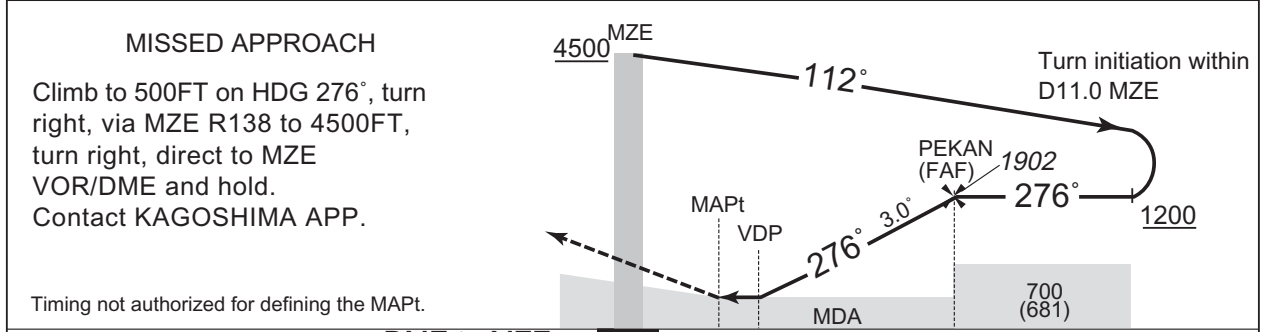
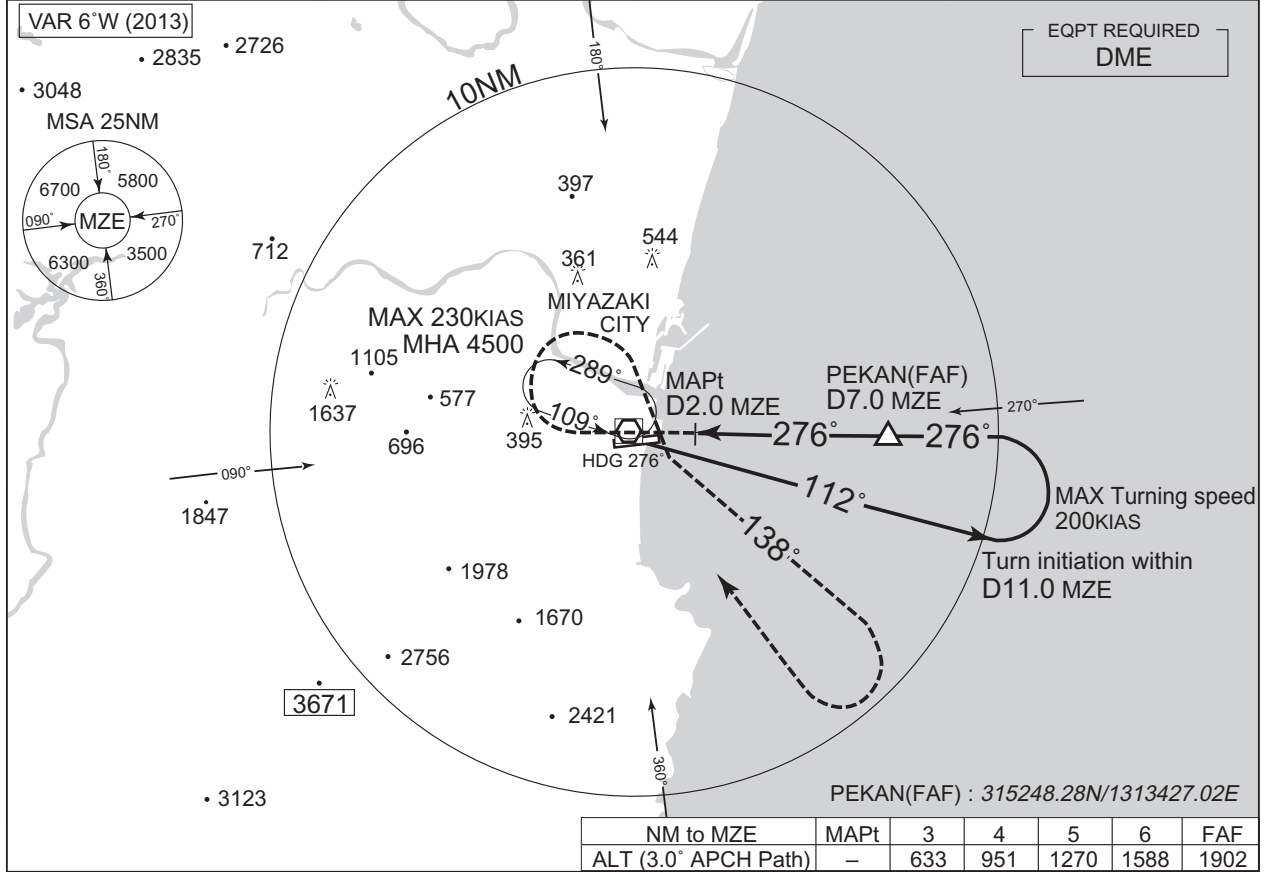

DME to MZE	1.2	2.0	2.4	7.0
NM to THR	0	0.8	1.2	5.8

MINIMA		THR elev. 21	AD elev. 19			
CAT			CIRCLING			
	MDA(H)	RVR/CMV	MDA(H)	VIS		
A	440 (421)	1500	520 (501)	1600		
B						
C					1800	2400
D					2000	3200

RJFM / MIYAZAKI

Visual REP



Call sign	BRG / DIST from ARP	Remarks
有田 Arita	318°/6.5NM	東九州自動車道大淀川橋 Bridge
相生 Aioi	336°/5.3NM	宮崎西環状線相生橋 Bridge
塩路 Shioji	022°/5.7NM	一ツ葉有料道路一ツ葉P A Parking Area
一ツ葉 Hitotsuba	023°/3.3NM	サンビーチ 一ツ葉 Beach
加江田 Kaeda	182°/3.7NM	加江田川河口 River-mouth
白浜 Shirahama	166°/5.8NM	戸崎鼻先端のホテル Hotel
田野 Tano	251°/8.1NM	宮崎自動車道田野 I C Interchange

宮崎特別管制区

Miyazaki Positive Control Area

NAME	LATERAL LIMITS	UPPER LIMIT (AMSL)	UNIT PROVIDING SERVICE	REMARKS
		LOWER LIMIT (AMSL) M(ft)		
1	2	3	4	5
宮崎 MIYAZAKI	下記に示される区域 The area shown below		Primary Kagoshima APP 121.4 120.9 362.3 Secondary Miyazaki TWR 118.3 261.2	当該空域を飛行しようとする航空機は、鹿児島アプローチ又は宮崎タワーに連絡し、コールサイン、現在位置、高度及び意図を通報し指示を受けること。 Pilot of aircraft operating in this area shall contact Kagoshima Approach or Miyazaki Tower for ATC instructions giving informations on aircraft identification, positions, altitude and pilot's intentions.

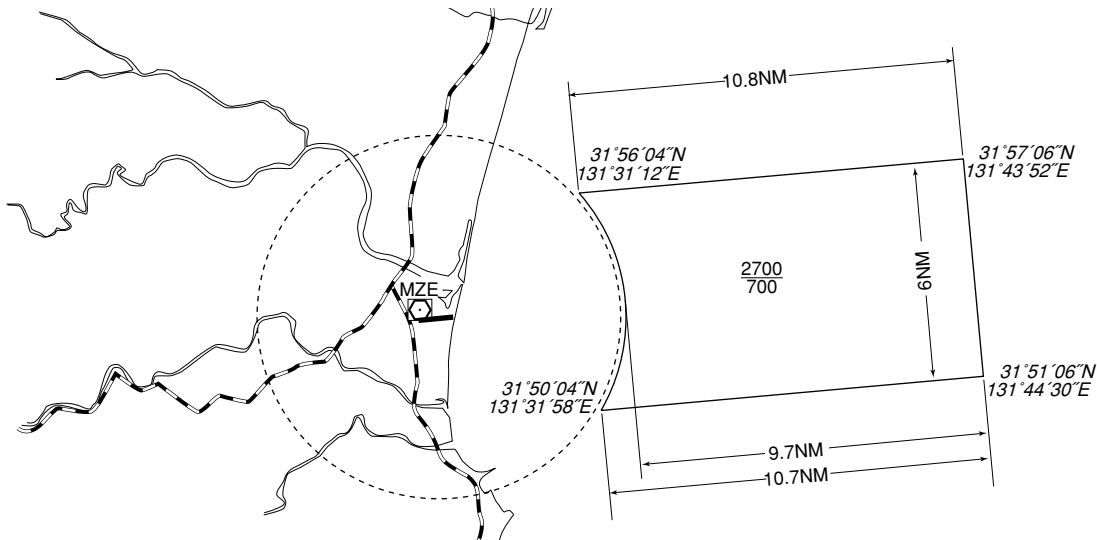

ILS

MIYAZAKI AP

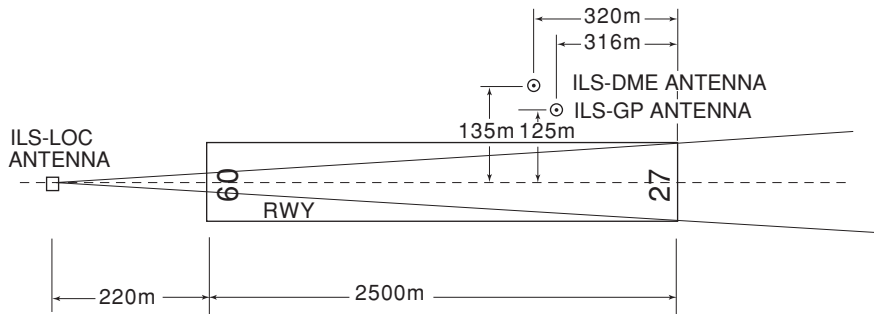

REMARKS:1.LOC beam BRG(MAG) 272°
2.HGT of ILS REF datum 16.5m(54ft)
3.GP Angle 3.0°
4.ELEV of ILS-DME 9.4m

