

AD 2 AERODROMES

RJEB AD 2.1 AERODROME LOCATION INDICATOR AND NAME

RJEB - MONBETSU

RJEB AD 2.2 AERODROME GEOGRAPHICAL AND ADMINISTRATIVE DATA

1	ARP coordinates and site at AD	441815N 1432415E 132°/1km FM RWY 32 THR
2	Direction and distance from (city)	3.8NM NW of MONBETSU city
3	Elevation/ Reference temperature	58ft / 24°C(2004-2008)
4	Geoid undulation at AD ELEV PSN	99.25ft
5	MAG VAR/ Annual change	9°W(2000) / 2.1'E
6	AD Administration, address, telephone, telefax, telex, AFS, e-mail and/or Web-site addresses	HOKKAIDO. PUBLIC.AP Okhotsk-Monbetsu Airport Administration Office (Hokkaido prefectural government) 19-3 Komukai Monbetsu-city Hokkaido Tel 0158-24-1336 , 1337 Fax 0158-24-1338 URL:http://www.abashiri.pref.hokkaido.lg.jp/ds/adg/rjeb1.htm
7	Types of traffic permitted(IFR/ VFR)	IFR/VFR
8	Remarks	Nil

RJEB AD 2.3 OPERATIONAL HOURS

1	AD Administration	0000 - 0800
2	Customs and immigration	On Request Customs: 0158-23-3500 Immigration: 0166-38-6755
3	Health and sanitation	Quarantine(human): On request(0166-83-5180) Quarantine(animal, plant): Nil
4	AIS Briefing Office	Nil
5	ATS Reporting Office(ARO)	Nil
6	MET Briefing Office	H24(NEW CHITOSE)
7	ATS	0000 - 0800 Remarks: Airport Remote Mobile Communicaton Service provided by New Chitose FSC.
8	Fuelling	Nil
9	Handling	0000 - 0800
10	Security	0000 - 0800
11	De-icing	Nil
12	Remarks	Nil

RJEB AD 2.4 HANDLING SERVICES AND FACILITIES

1	Cargo-handling facilities	Nil
2	Fuel/ oil types	Nil
3	Fuelling facilities/ capacity	Nil
4	De-icing facilities	Nil
5	Hangar space for visiting aircraft	Nil
6	Repair facilities for visiting aircraft	Nil
7	Remarks	Nil

RJEB AD 2.5 PASSENGER FACILITIES

1	Hotels	Nil
2	Restaurants	Coffee Shop 0200-0500
3	Transportation	Buses and Taxi
4	Medical facilities	Hospital in Monbetsu city 7km
5	Bank and Post Office	Nil
6	Tourist Office	Nil
7	Remarks	Nil

RJEB AD 2.6 RESCUE AND FIRE FIGHTING SERVICES

1	AD category for fire fighting	CAT 7
2	Rescue equipment	Chemical fire fighting truck x 2 , Emergency medical equipments conveyance truck
3	Capability for removal of disabled aircraft	Nil
4	Remarks	Nil

RJEB AD 2.7 SEASONAL AVAILABILITY-CLEARING

1	Types of clearing equipment	Snow Removal Equipments : truck x 5 , motor grader x 1, rotary x 3 , dozer x 3, snow sweeper x 3, anti-freezing-agent spreader x 1 Available period: from NOV to MAY
2	Clearance priorities	1.RWY 2.TWY 3.APRON
3	Remarks	Nil

RJEB AD 2.8 APRONS, TAXIWAYS AND CHECK LOCATIONS DATA

1	Apron surface and strength	Surface:cement-concrete Strength:PCN 48/R/B/X/T
2	Taxiway width, surface and strength	Width:23m, Surface:asphalt-concrete Strength:PCN 52/F/B/X/T
3	ACL and elevation	Not available
4	VOR checkpoints	Not available
5	INS checkpoints	Spot NR 1 441820.93N 1432425.33E 2 441821.90N 1432423.82E 3 441822.88N 1432422.31E
6	Remarks	Nil

RJEB AD 2.9 SURFACE MOVEMENT GUIDANCE AND CONTROL SYSTEM AND MARKINGS

1	Use of aircraft stand ID signs, TWY guide lines and Visual docking/ parking guidance system of aircraft stands	Nil
2	RWY and TWY markings and LGT	RWY:14/32 (Marking) RWY designation, RWY CL, RWY THR, Aiming point, TDZ, RWY side stripe, RWY turn pad CL, RWY turn pad edge (LGT) RCLL, REDL, RTHL, RENL, RTZL(RWY32), WBAR(RWY32), Turning point indicator LGT, RWY DIST marker LGT TWY: (Marking) TWY CL, RWY HLDG PSN, TWY side stripe (LGT) TWY edge LGT, TWY CL LGT
3	Stop bars	Nil
4	Remarks	(Marking) Overrun area (LGT) Apron flood LGT

滑走路180° 転回実施要領

1. 滑走路中心線からターニングパッド中心線標識に従って進行する。
2. 転回灯1が一直線に見えるように進行し、転回灯2が一直線に見えた時転回を開始する。

Procedure of 180° turn on RWY

1. Proceed along the RWY Center Line Marking to the starting point of the RWY Turn Pad Center Line Marking ; then
2. Proceed along the RWY Turn Pad Center Line Marking to see the Turning Point Indicator Light 1 on a straight line, then commence turn at the spot where you (pilot) can see the Turning Point Indicator Light 2 on a straight line at an angle of 9 o'clock.

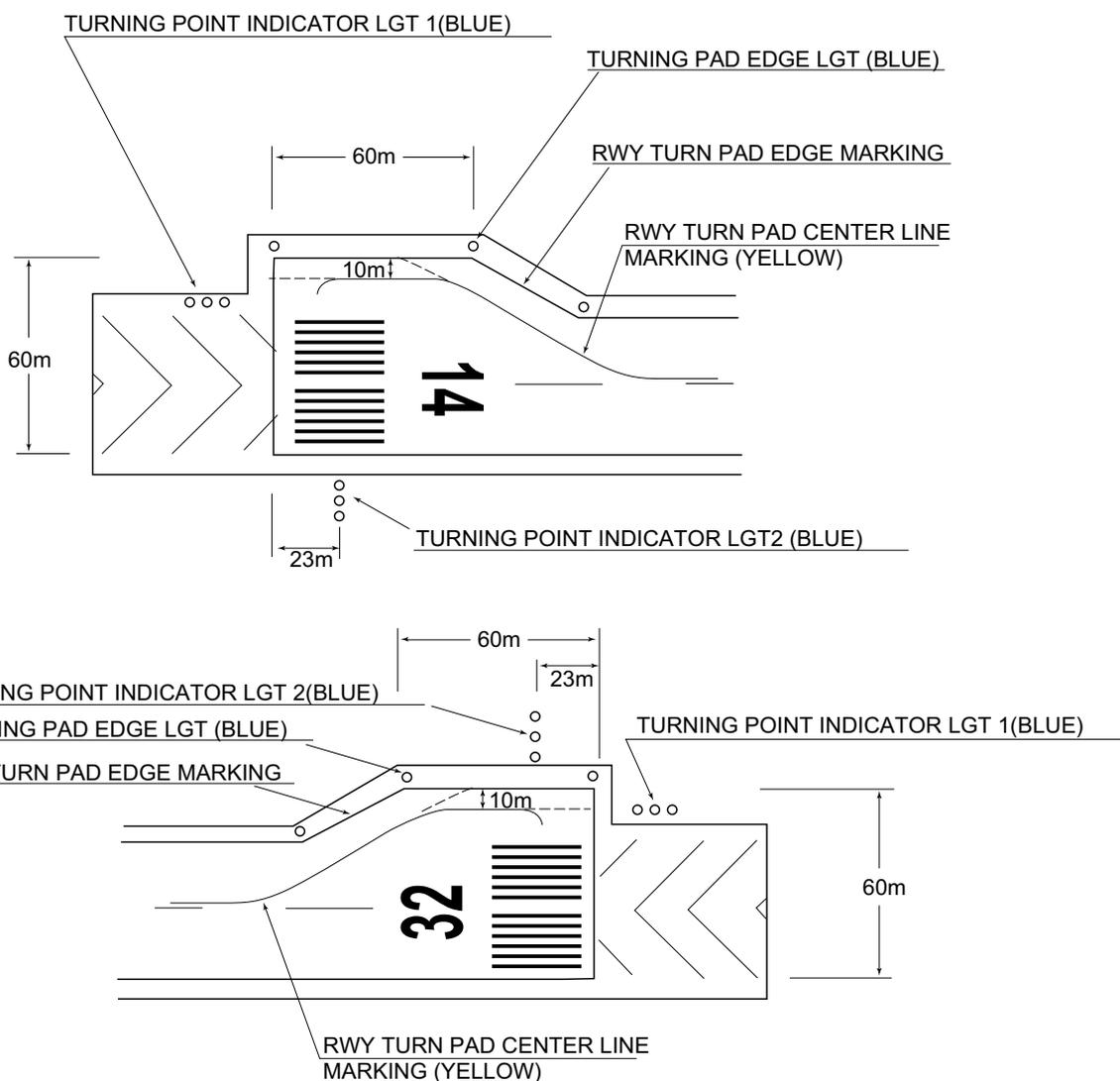

RJEB AD 2.10 AERODROME OBSTACLES

■ In Area2 See Obstacle data

■ Other obstacles

OBST ID/designation	Obstacle type	Coordinates	Elevation	Markings/LGT	Remarks
RJEB1	MT	-	1,094.8ft	Nil	See RJEB AD2.14 Figure

■ In Area3 To be developed

RJEB AD 2.11 METEOROLOGICAL INFORMATION PROVIDED

1	Associated MET Office	NEW CHITOSE
2	Hours of service MET Office outside hours	H24(NEW CHITOSE)
3	Office responsible for TAF preparation Periods of validity	Nil
4	Trend forecast Interval of issuance	Nil
5	Briefing/ consultation provided	Briefing is available upon inquiry at NEW CHITOSE
6	Flight documentation Language(s) used	C En
7	Charts and other information available for briefing or consultation	S ₆ , U ₈₅ , U ₇ , U ₅ , U ₃ , U ₂₅ , U ₂ /T _F , P _S , P ₅ , P ₃ , P ₂₅ , P _{SWE} , P _{SWF} , P _{SWG} , P _{SWI} , P _{SWM} , P _{SW} (domestic), E, C, W _E , W _F , W _G , W _I , W, N
8	Supplementary equipment available for providing information	Nil
9	ATS units provided with information	REMOTE
10	Additional information(limitation of service, etc.)	Nil

RJEB AD 2.12 RUNWAY PHYSICAL CHARACTERISTICS

Designations RWY NR	TRUE BRG	Dimensions of RWY(M)	Strength(PCN) and surface of RWY	THR coordinates THR geoid undulation	THR elevation and highest elevation of TDZ of precision APP RWY
1	2	3	4	5	6
14	131.93°	2000×45	PCN 58/F/D/X/T 52/F/B/X/T(1) Asphalt Concrete	441835.73N 1432340.93E 97.4ft	THR ELEV : 80ft
32	311.93°	2000×45	PCN 58/F/D/X/T 52/F/B/X/T(1) Asphalt Concrete	441752.44N 1432448.06E 97.4ft	THR ELEV : 71.85ft TDZ ELEV : 71.85ft
Slope of RWY	Strip Dimensions(M)	RESA (Overrun) Dimensions (M)	Remarks		
7	10	11	14		
see AD 2.24 AD Chart	2120×300 2120×300	40×300 190×(MNM:137 MAX:300)* *For detail, ask airport administrator	RWY Grooving:2000×45m (1)BTN 70m and 470m FM RWY 32 THR. BTN 820m and 1270m FM RWY 32 THR. BTN 130m and 590m FM RWY 14 THR.		

RJEB AD 2.13 DECLARED DISTANCES

RWY Designator	TORA (m)	TODA (m)	ASDA (m)	LDA (m)	Remarks
1	2	3	4	5	6
14	2000	2000	2000	2000	Nil
32	2000	2000	2000	2000	Nil

RJEB AD 2.14 APPROACH AND RUNWAY LIGHTING

RWY Designator	APCH LGT type LEN INTST	RTHL Color WBAR	PAPI (VASIS) Angle DIST FM THR MEHT	RTZL LEN	RCLL LEN Spacing Color INTST	REDL LEN Spacing Color INTST	RENL Color WBAR	STWL LEN Color
1	2	3	4	5	6	7	8	9
14	SALS (*1) 420m LIH	Green Nil	PAPI 3.0°/Left 445.5m 61ft	Nil	2000m 30m Coded color (White/Red) LIH	2000m 60m Coded color (White/Yellow) LIH	Red	Nil(*2)
32	PALS (CAT I) 900m LIH	Green Green	PAPI 3.0°/Left 391.6m 61ft	900m	2000m 30m Coded color (White/Red) LIH	2000m 60m Coded color (White/Yellow) LIH	Red	Nil(*2)
Remarks								
10								
SALS with APCH LGT beacon (600m and 900m FM RWY THR) (*1) Overrun area edge LGT(LEN60m color:Red) (*2) CGL for RWY 14 Usable area of PAPI of RWY14 is within 3.5 NM FM RWY 14 THR (See Below Figure)								

Usable area of PAPI

滑走路14末端側進入角指示灯の使用範囲は、障害物（山）のため滑走路14側末端から3.5NM以内とする。

Usable area of PAPI for runway 14 is within 3.5NM from runway 14 threshold due to obstructions (mountain).

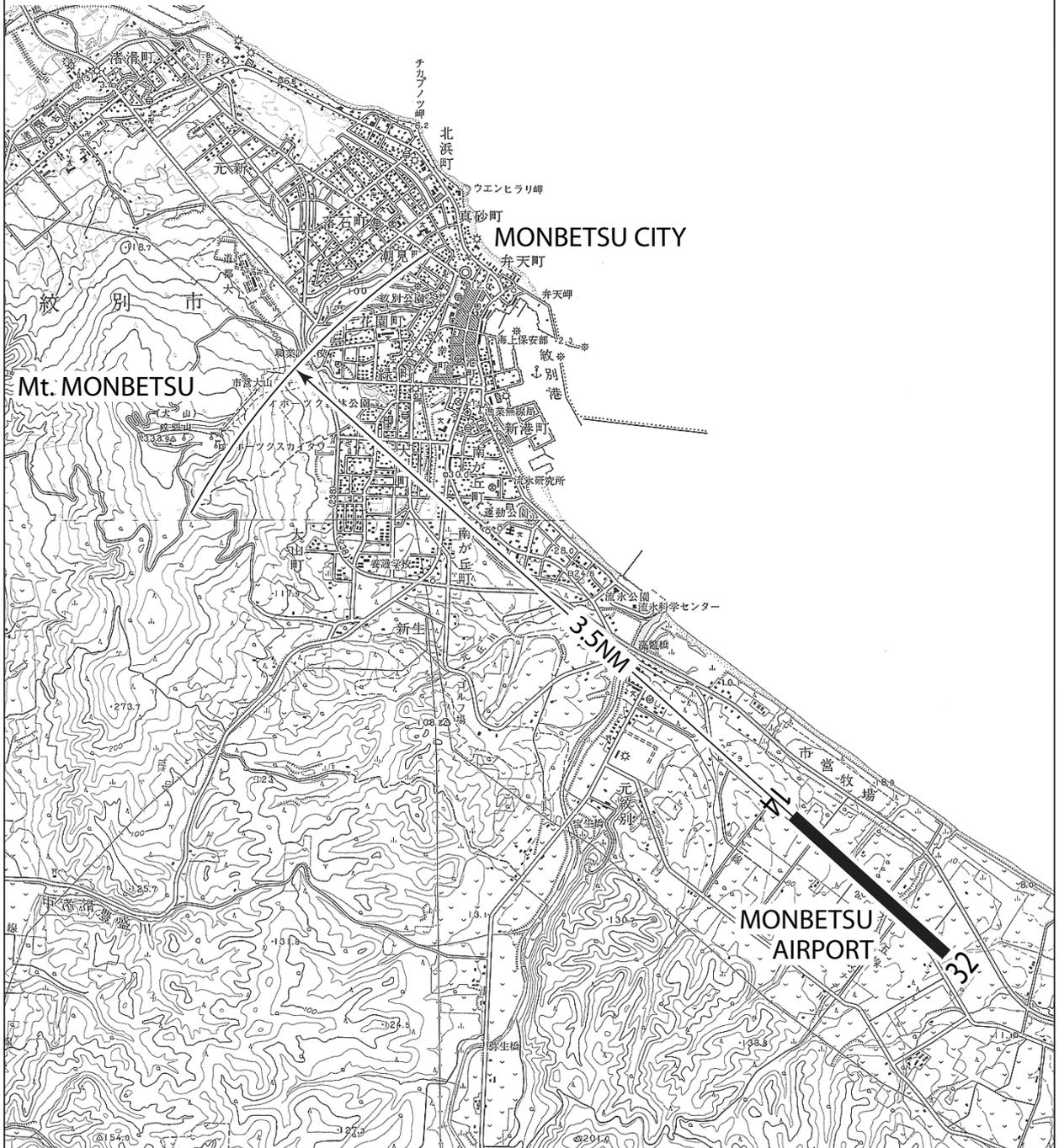

RJEB AD 2.15 OTHER LIGHTING, SECONDARY POWER SUPPLY

1	ABN/IBN location, characteristics and hours of operation	ABN: 441823N/1432434E, White/Green EV4.3sec, HO
2	LDI location and LGT Anemometer location and LGT	LDI:Nil Anemometer: RWY14:300m from RWY14 THR, LGTD RWY32:295m from RWY32 THR, LGTD
3	TWY edge and centerline lighting	TWY edge and center line lights installed, see AD 2.9
4	Secondary power supply/switch-over time	Within 1sec : REDL, RCLL, RTHL, RENL, WBAR, Turning point indicator LGT, Overrun area edge LGT Within 15sec : Other LGT
5	Remarks	WDI LGT

RJEB AD 2.16 HELICOPTER LANDING AREA

Nil

RJEB AD 2.17 ATS AIRSPACE

Designation and lateral limits		Vertical limits (ft)	Airspace classification	ATS unit call sign Language	Transition altitude	Remarks
1		2	3	4	5	6
Monbetsu Information Zone	Area within a radius of 5NM(9km) of Monbetsu ARP	3,000 or below	E	Monbetsu Remote En	Nil	

RJEB AD 2.18 ATS COMMUNICATION FACILITIES

Service designation	Call sign	Frequency	Hours of operation	Remarks
1	2	3	4	5
A/G	Monbetsu Remote	118.15MHz	0000 - 0800	RAG controlled by New Chitose FSC

RJEB AD 2.19 RADIO NAVIGATION AND LANDING AIDS

Type of aid (VOR declination)	ID	Frequency	Hours of operation	Position of transmitting antenna coordinates	Elevation of DME transmitting antenna	Remarks
1	2	3	4	5	6	7
VOR (9°W/2016)	MVE	112.9MHz	H24	441818.96N 1432342.33E		
DME	MVE	1163MHz (CH-76X)	H24	441818.96N 1432342.33E	159ft	DME Unusable: 150°-170° beyond 30nm BLW 4000ft. 170°-200° beyond 30nm BLW 6000ft. 260°-280° beyond 30nm BLW 6000ft.
ILS-LOC 32	IMV	111.55MHz	0000 - 0800	441840.82N 1432333.00E		LOC: 235m(771ft)away FM RWY14 THR, BRG(MAG)321°.
ILS-GP 32	-	332.75MHz	0000 - 0800	441756.35N 1432433.82E		GP: 315m(1033ft) inside FM RWY32 THR, 120m(394ft) SW of RCL. HGT of ILS Ref datum 16.5m (54ft). GP angle 3.0°
ILS-DME 32	IMV	1139MHz (CH-52Y)	0000 - 0800	441756.18N 1432433.23E	87ft	DME: 321m(1053ft) inside FM RWY32 THR, 133m(436ft) SW of RCL.

ILS

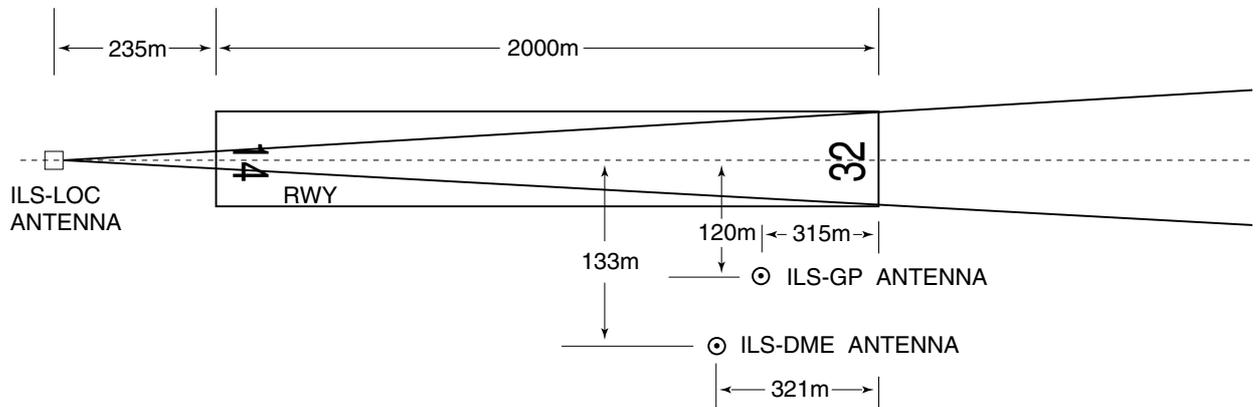

- REMARKS :
- | | |
|-------------------------|-------------|
| 1. LOC beam BRG(MAG) | 321° |
| 2. HGT of ILS REF datum | 16.5m(54ft) |
| 3. GP Angle | 3.0° |
| 4. ELEV of ILS-DME | 26.6m(87ft) |

RJEB AD 2.20 LOCAL TRAFFIC REGULATIONS

1. Airport regulations

Aircraft operations other than scheduled flights or in an emergency
On use of this airport, aircraft operator is required to obtain the prior permission of the Airport Administrator.

2. Taxiing to and from stands

Nil

3. Parking area for small aircraft(General aviation)

Nil

4. Parking area for helicopters

Nil

5. Apron - taxiing during winter conditions

Nil

6. Taxiing - limitations

Nil

7. School and training flights - technical test flights - use of runways

Nil

8. Helicopter traffic - limitation

Nil

9. Removal of disabled aircraft from runways

Nil

RJEB AD 2.21 NOISE ABATEMENT PROCEDURES

Nil

RJEB AD 2.22 FLIGHT PROCEDURES

TAKE OFF MINIMA

	RWY	ACFT CAT	REDL & RCLL		REDL or RCLL or RCL Marking		NIL (DAYTIME ONLY)	
			RVR	VIS	RVR	VIS	RVR	VIS
Multi-Engine ACFT with TKOF ALTN AP FILED	14	A,B,C,D	-	400m	-	400m	-	500m
	32	A,B,C,D	400m	400m	400m	400m	-	500m
OTHER	14	A,B,C,D	AVBL LDG MINIMA					
	32	A,B,C,D						

RJEB AD 2.23 ADDITIONAL INFORMATION

Nil

RJEB AD 2.24 CHARTS RELATED TO AN AERODROME

- Aerodrome/Heliport Chart
- Standard Departure Chart - Instrument (MONBETSU REVERSAL)
- Standard Departure Chart - Instrument (LUBEK-RNAV)
- Instrument Approach Chart (ILS or LOC RWY32)
- Instrument Approach Chart (RNAV(RNP) RWY14)
- Instrument Approach Chart (RNAV(RNP) RWY32)
- Instrument Approach Chart (VOR A)
- Other Chart (Visual REP)
- Other Chart (MVA CHART)

INTENTIONALLY LEFT BLANK

RJEB / MONBETSU

AD CHART

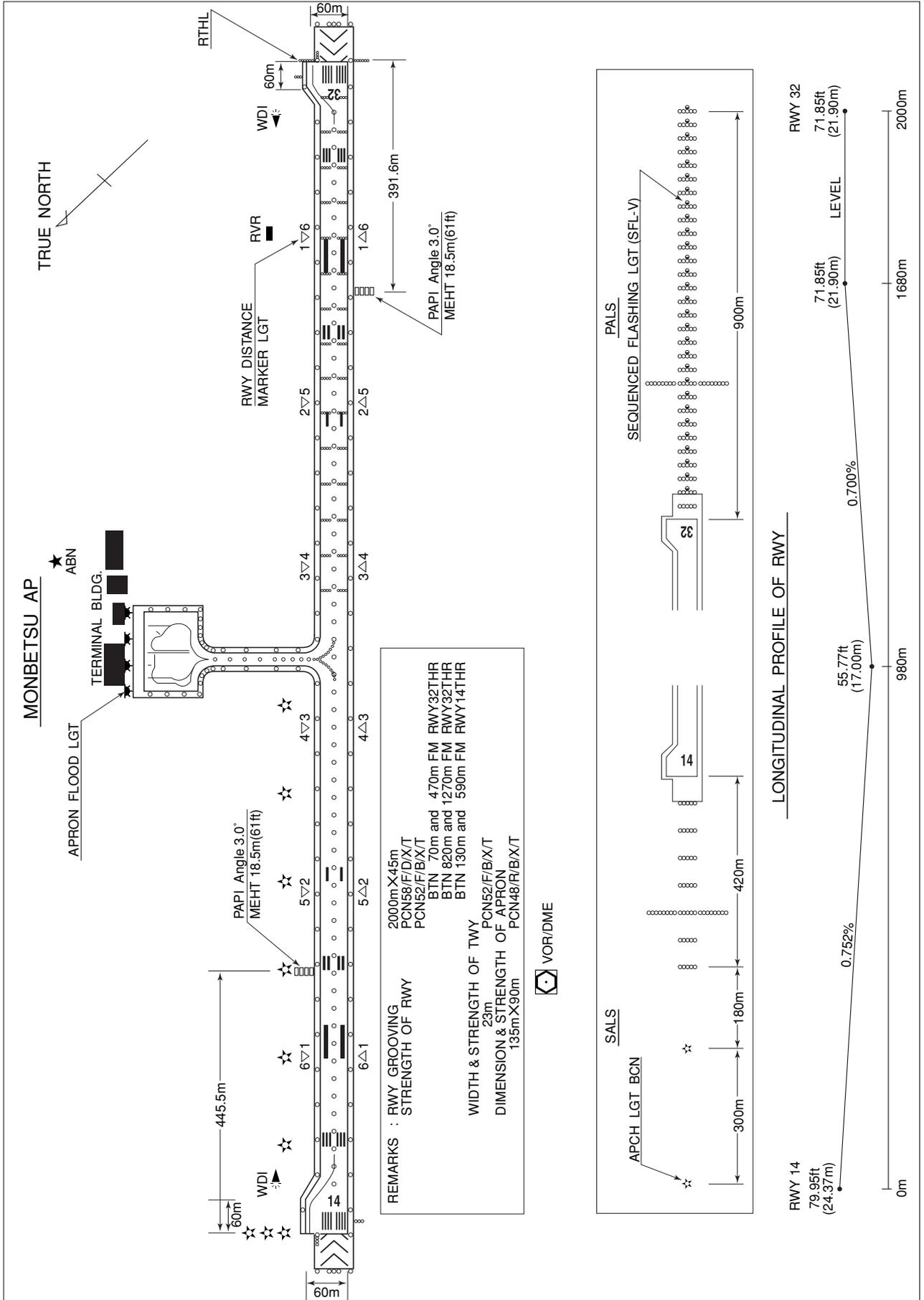

INTENTIONALLY LEFT BLANK

STANDARD DEPARTURE CHART-INSTRUMENT

RJEB / MONBETSU

SID and TRANSITION

MONBETSU REVERSAL FIVE DEPARTURE

RWY14 : Climb RWY HDG to 600FT, turn left HDG050°, to 2500FT turn left,...
RWY32 : Climb RWY HDG to 500FT, turn right HDG050°, to 2500FT turn right,...
...direct to MVE VOR/DME.
Cross MVE VOR/DME at or above 4000FT.

Note RWY14 : 5.0% climb gradient required up to 900FT.
OBST ALT 591FT located at 2.7NM 156° FM end of RWY14.
RWY32: 4.3% climb gradient required up to 800FT.
OBST ALT 657FT located at 3.5NM 316° FM end of RWY32.

LUBEK TRANSITION

From over MVE VOR/DME, proceed via MVE R236 to LUBEK.
Cross LUBEK at or above 8000FT.

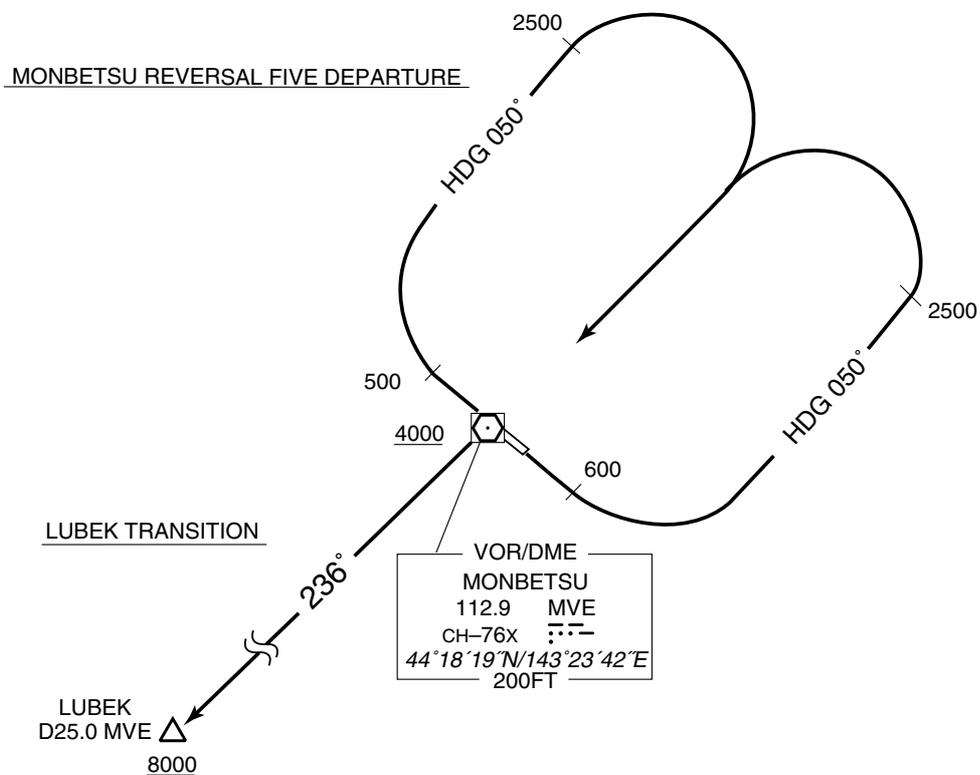

INSTRUMENT APPROACH CHART

RJEB / MONBETSU ILS or LOC RWY32

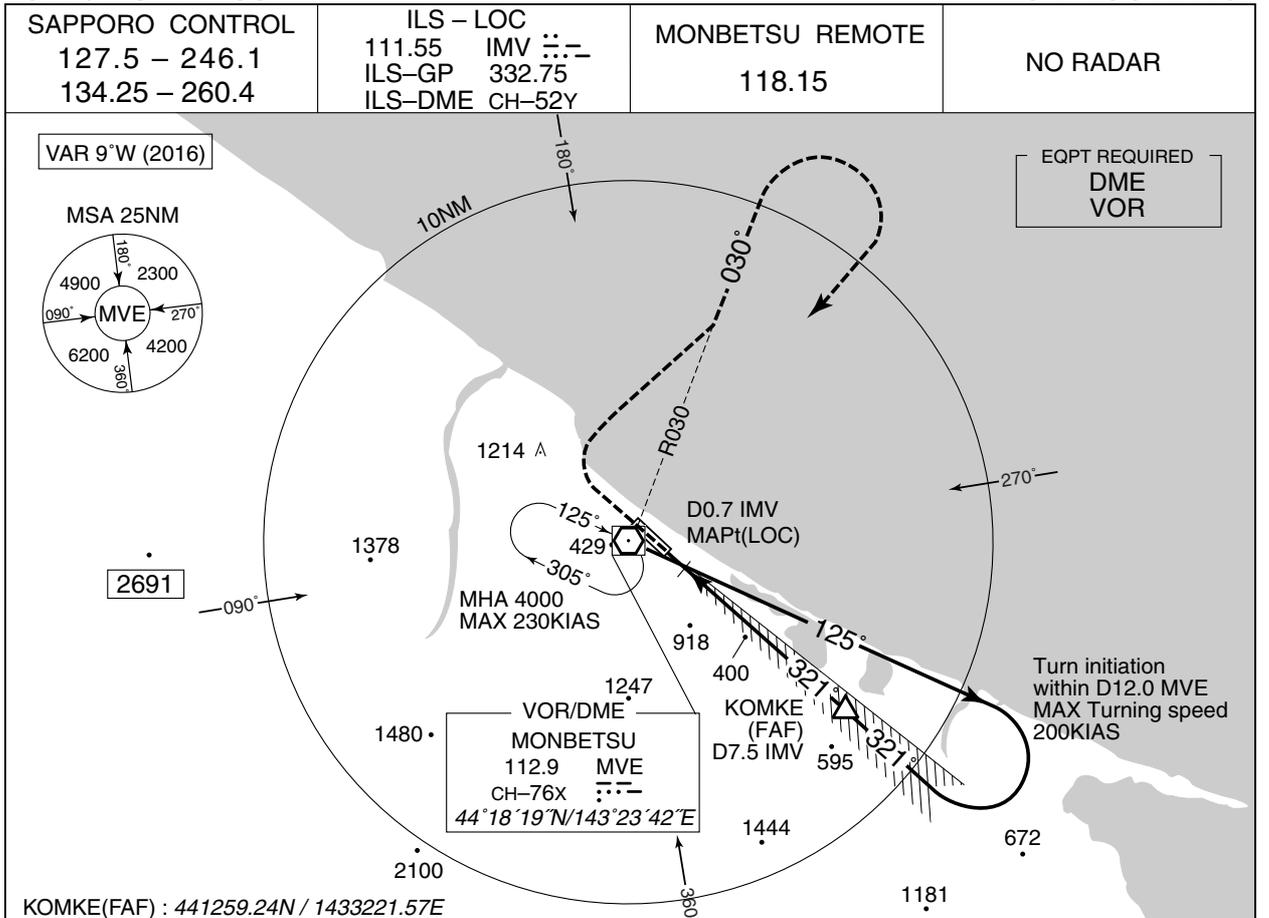

NM to IMV	MAPt	2	3	4	5	6	7	FAF
ALT (3.0° APCH Path)	-	703	1022	1340	1659	1977	2296	2448

MISSED APPROACH

Turn right, climb via MVE R030 to 2500FT, turn right, direct to MVE VOR/DME and hold at 4000FT. Contact MONBETSU REMOTE.

Timing not authorized for defining the MAPt. No turn before IMV 0.7DME.

*Not applicable for CAT D circling
Turn initiation within D12.0 MVE

DME to IMV	0.2	0.7	1.5	2.7	7.5
NM to THR	0	0.5	1.3	2.5	7.3

Missed APCH climb gradient MNM 4.0%

CAT	CAT I		LOC		CIRCLING	
	DA(H)	RVR/CMV	MDA(H)	RVR/CMV	MDA(H)	VIS
A	272 (200)	550	510 (452)	1200	510 (452)	1600
B					530 (472)	
C					830 (772)	2400
D					1150 (1092)	3200

Circling to NORTH side of RWY only.
MINIMA with Missed APCH climb gradient of 2.5% are not established.

INSTRUMENT APPROACH CHART

RJEB / MONBETSU

VOR A

SAPPORO CONTROL 127.5 – 246.1 134.25 – 260.4	MONBETSU VOR/DME 112.9 MVE CH-76X 44°18'19"N/143°23'42"E	MONBETSU REMOTE 118.15	NO RADAR
--	---	---------------------------	----------

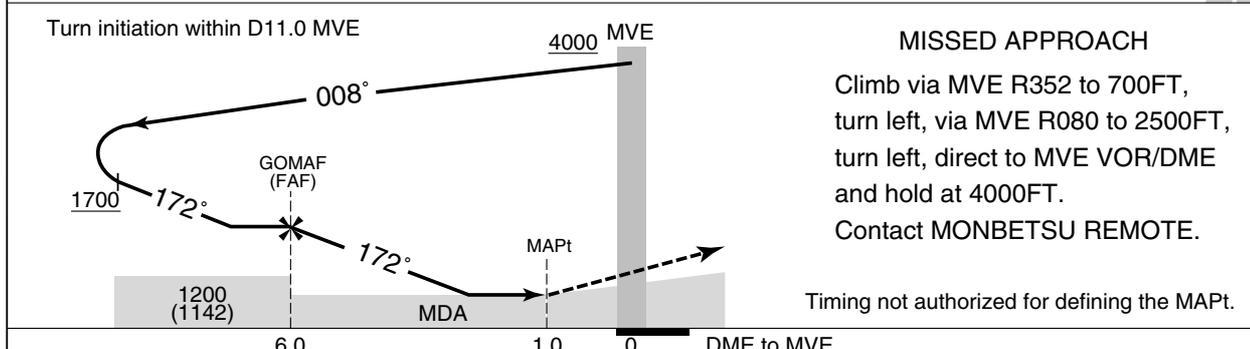
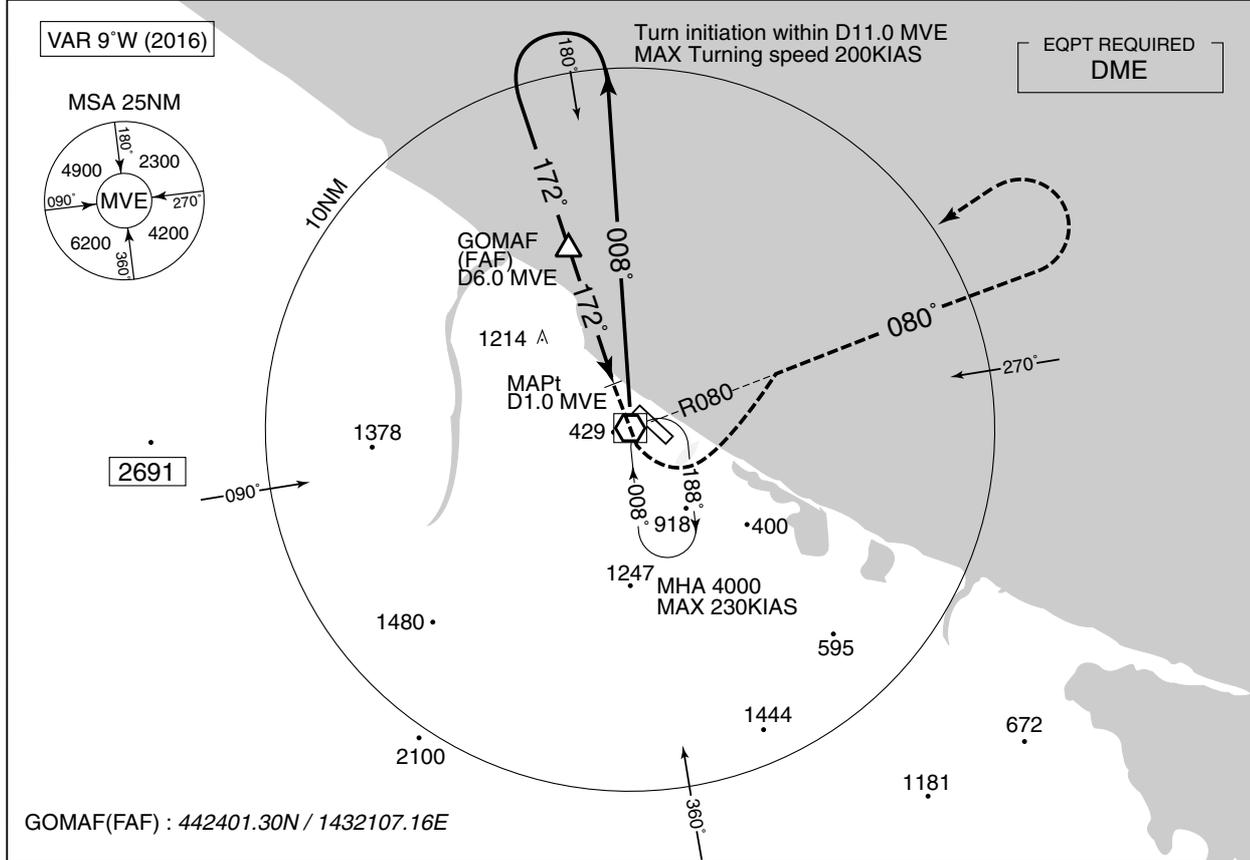

Missed APCH climb gradient MNM 3.5%

MINIMA		AD elev. 58
CAT	CIRCLING	
	MDA(H)	VIS
A	580 (522)	1600
B	830 (772)	2400
C	1150 (1092)	3200

Circling to NORTH side of RWY only.
MINIMA with Missed APCH climb gradient of 2.5% are not established.

RJEB / MONBETSU

Visual REP



※図中に標高を示す数字がある場合、単位はメートル(m)である。The unit of measurement used to express elevation is meter(m).

CHANGE : Map updated. BRG/DIST from ARP.

Call sign	BRG / DIST from ARP	Remarks
沙留 Saru	317°T / 11.3NM	岬 Cape
渚滑 Shokotsu	323°T / 5.8NM	渚滑川河口 Mouth of Shokotsu river
コムケ湖 Komukeko	123°T / 5.5NM	湖 Lake
上渚滑 Kamishokotsu	242°T / 7.3NM	橋 Bridge
竜宮台 Ryuguudai	114°T / 18.0NM	灯台 Lighthouse
鴻之舞 Kounomai	193°T / 10.6NM	発電所 Power Station
遠軽 Engaru	161°T / 15.5NM	駅 JR Station

RJEB / MONBETSU

Minimum Vectoring Altitude CHART

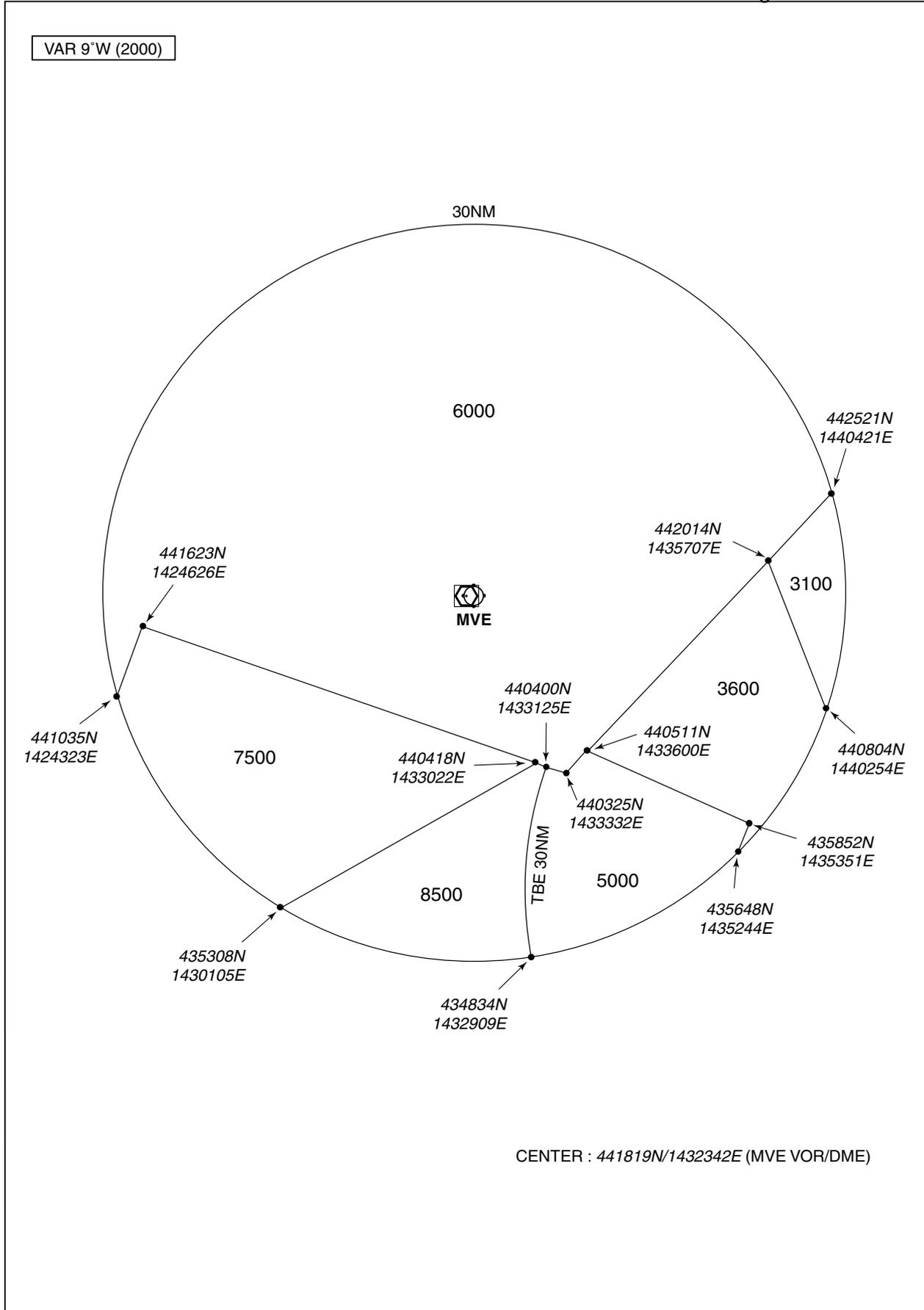

STANDARD DEPARTURE CHART-INSTRUMENT

RJEB / MONBETSU

RNAV SID

LUBEK ONE DEPARTURE

Basic RNP1

Note GNSS required.

VAR 9°W (2014)

LUBEK ONE DEPARTURE

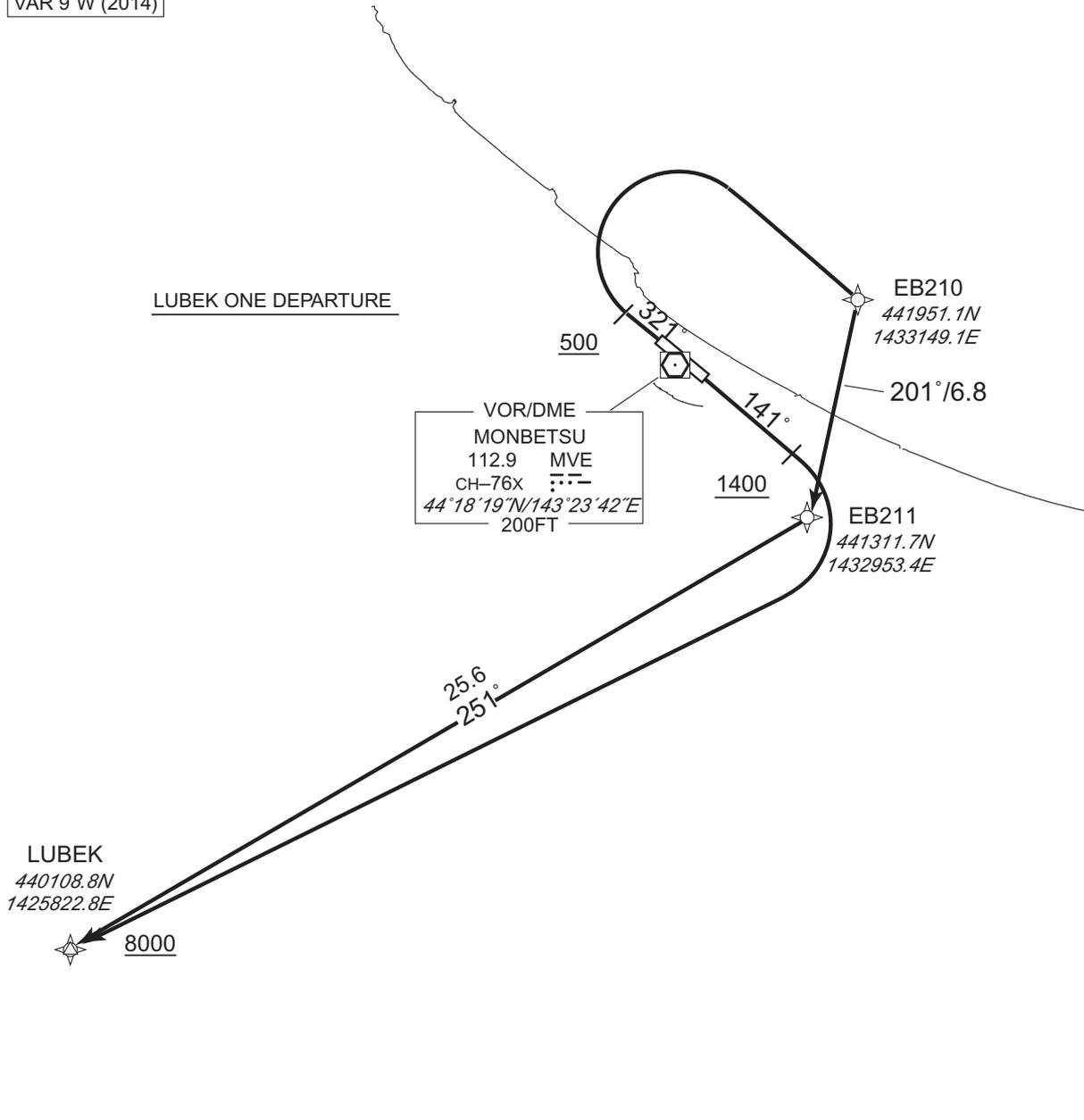

LUBEK ONE DEPARTURE

RWY14 : Climb on HDG141° at or above 1400FT, turn right direct to LUBEK at or above 8000FT.

RWY32 : Climb on HDG321° at or above 500FT, turn right direct to EB210, to EB211, to LUBEK at or above 8000FT.

Note RWY14 : 5.0% climb gradient required up to 1400FT.
OBST ALT 1182FT located at 2.9NM 172° FM end of RWY14.

RWY32 : 5.0% climb gradient required up to 700FT.
OBST ALT 657FT located at 3.4NM 318° FM end of RWY32.

STANDARD DEPARTURE CHART-INSTRUMENT

RJEB / MONBETSU

RNAV SID

LUBEK ONE DEPARTURE

RWY14

Serial Number	Path Descriptor	Waypoint Identifier	Fly Over	Course [°M(°T)]	Magnetic Variation	Distance (NM)	Turn Direction	Altitude (FT)	Speed (KIAS)	Vertical Angle	Navigation Specification
001	VA	—	—	141 (132.0)	-9.2	—	—	+1400	—	—	Basic RNP1
002	DF	LUBEK	—	—	-9.2	—	R	+8000	—	—	Basic RNP1

RWY32

Serial Number	Path Descriptor	Waypoint Identifier	Fly Over	Course [°M(°T)]	Magnetic Variation	Distance (NM)	Turn Direction	Altitude (FT)	Speed (KIAS)	Vertical Angle	Navigation Specification
001	VA	—	—	321 (312.0)	-9.2	—	—	+500	—	—	Basic RNP1
002	DF	EB210	—	—	-9.2	—	R	—	—	—	Basic RNP1
003	TF	EB211	—	201 (191.7)	-9.2	6.8	—	—	—	—	Basic RNP1
004	TF	LUBEK	—	251 (242.1)	-9.2	25.6	—	+8000	—	—	Basic RNP1

INSTRUMENT APPROACH CHART

RJEB / MONBETSU

RNAV(RNP) RWY14

SAPPORO CONTROL 127.5 – 246.1 134.25 – 260.4	GNSS and RF required.	MONBETSU REMOTE 118.15	NO RADAR
--	-----------------------	---------------------------	----------

For uncompensated Baro-VNAV systems, procedure not authorized below -20°C / above 45°C

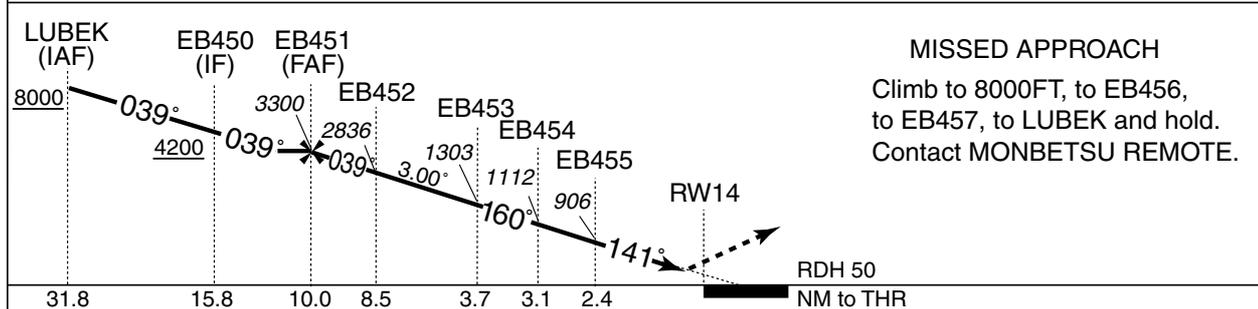
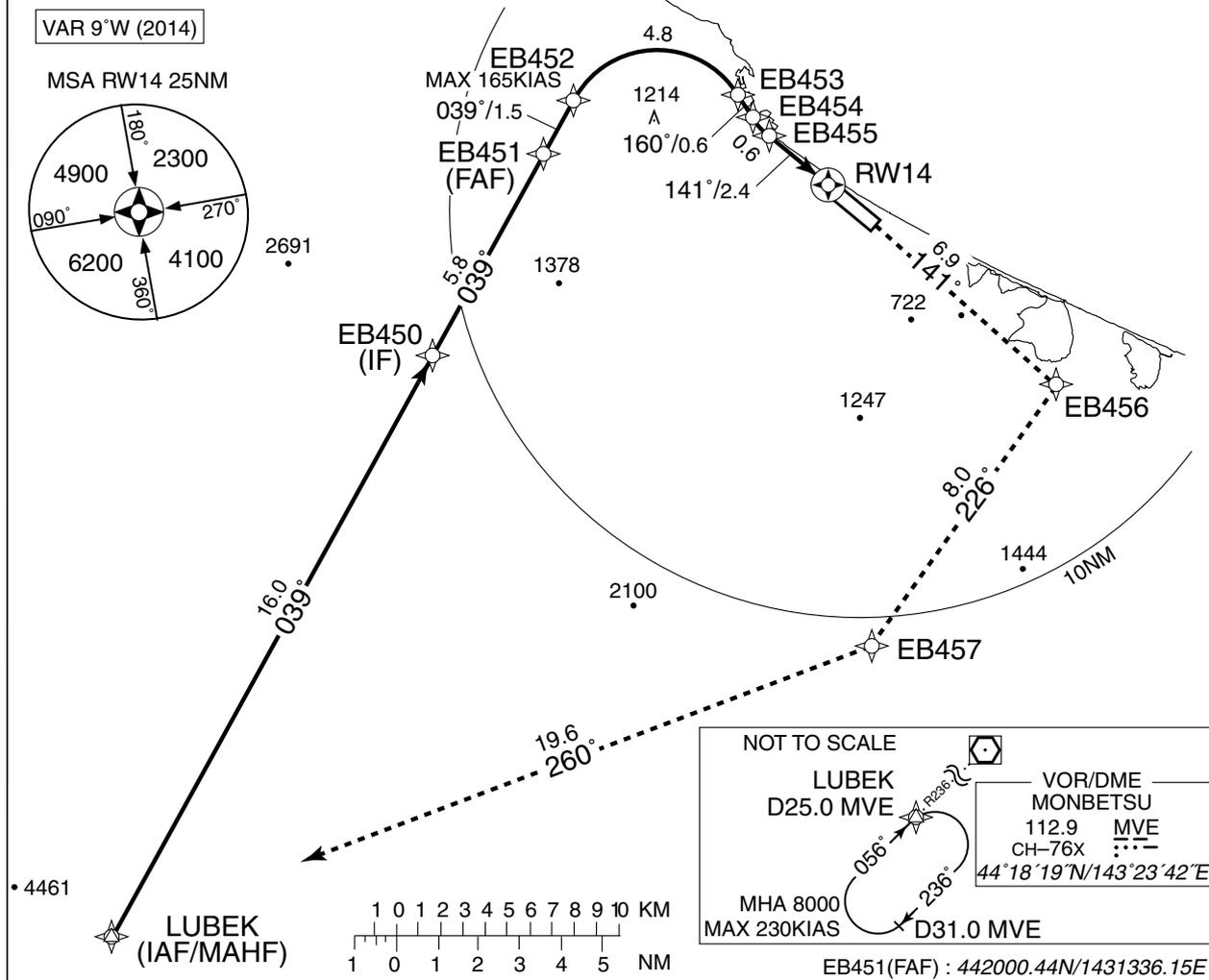

Missed APCH climb gradient MNM 5.0%

CAT	THR elev. 80		AD elev. 58	
	RNP 0.10		RNP 0.30	
	DA(H)	CMV	DA(H)	CMV
A	—	—	—	—
B	—	—	—	—
C	384 (304)	1400	653 (573)	1600
D		1600		1800

MINIMA with Missed APCH climb gradient of 2.5% are not established.

RNP AR
Special Authorization Required

INSTRUMENT APPROACH CHART

RJEB / MONBETSU

RNAV(RNP) RWY14

RNAV(RNP) RWY14

Coding Table

Serial Number	Path Descriptor	Waypoint Identifier	Fly Over	Course °M(°T)	Magnetic Variation	Distance (NM)	Turn Direction	Altitude (FT)	Speed (KIAS)	VPA/RDH (°/FT)	RNP Value
001	IF	LUBEK	—	—	-9.2	—	—	+8000	—	—	—
002	TF	EB450	—	039 (030.0)	-9.2	16.0	—	+4200	—	—	1.0
003	TF	EB451	—	039 (030.1)	-9.2	5.8	—	3300	—	—	1.0
004	TF	EB452	—	039 (030.2)	-9.2	1.5	—	2836	-165	-3.00	0.10 0.30
005	RF Center: EBRF1 r=2.30NM	EB453	—	—	-9.2	4.8	R	1303	—	-3.00	0.10 0.30
006	TF	EB454	—	160 (150.4)	-9.2	0.6	—	1112	—	-3.00	0.10 0.30
007	RF Center: EBRF2 r=2.01NM	EB455	—	—	-9.2	0.6	L	906	—	-3.00	0.10 0.30
008	TF	RW14	Y	141 (132.0)	-9.2	2.4	—	130	—	-3.00/50	0.10 0.30
009	TF	EB456	—	141 (132.0)	-9.2	6.9	—	—	—	—	1.0
010	TF	EB457	—	226 (216.9)	-9.2	8.0	—	—	—	—	1.0
011	TF	LUBEK	—	260 (251.0)	-9.2	19.6	—	8000	—	—	1.0

Waypoint Coordinates

Waypoint Identifier	Coordinates	RF Arc Center Identifier	Coordinates
LUBEK	440108.77N/1425822.82E	EBRF1	442006.33N/1431723.55E
EB450	441459.20N/1430931.88E	EBRF2	442143.27N/1432301.39E
EB451	442000.44N/1431336.15E		
EB452	442115.89N/1431437.46E		
EB453	442114.78N/1432010.52E		
EB454	442043.51N/1432035.39E		
EB455	442013.50N/1432109.15E		
RW14	441835.73N/1432340.93E		
EB456	441358.25N/1433050.46E		
EB457	440734.71N/1432409.46E		

INSTRUMENT APPROACH CHART

RJEB / MONBETSU

RNAV(RNP) RWY32

SAPPORO CONTROL 127.5 – 246.1 134.25 – 260.4	GNSS and RF required.	MONBETSU REMOTE 118.15	NO RADAR
--	-----------------------	---------------------------	----------

For uncompensated Baro-VNAV systems, procedure not authorized below -20°C / above 45°C

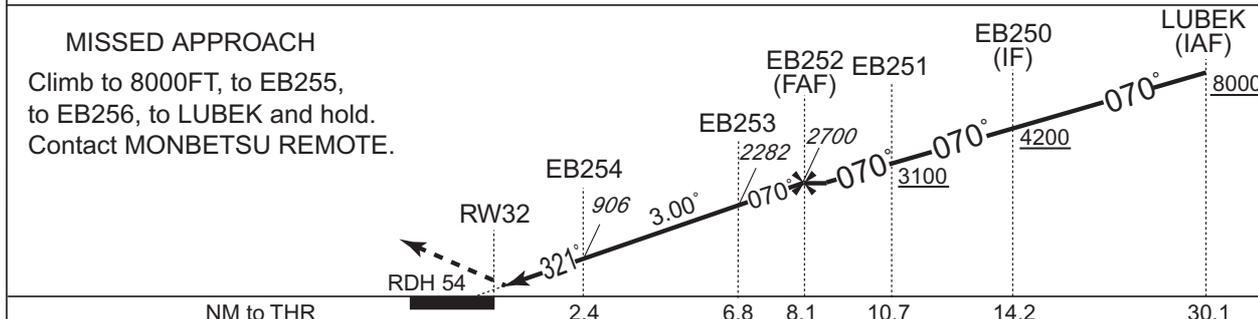
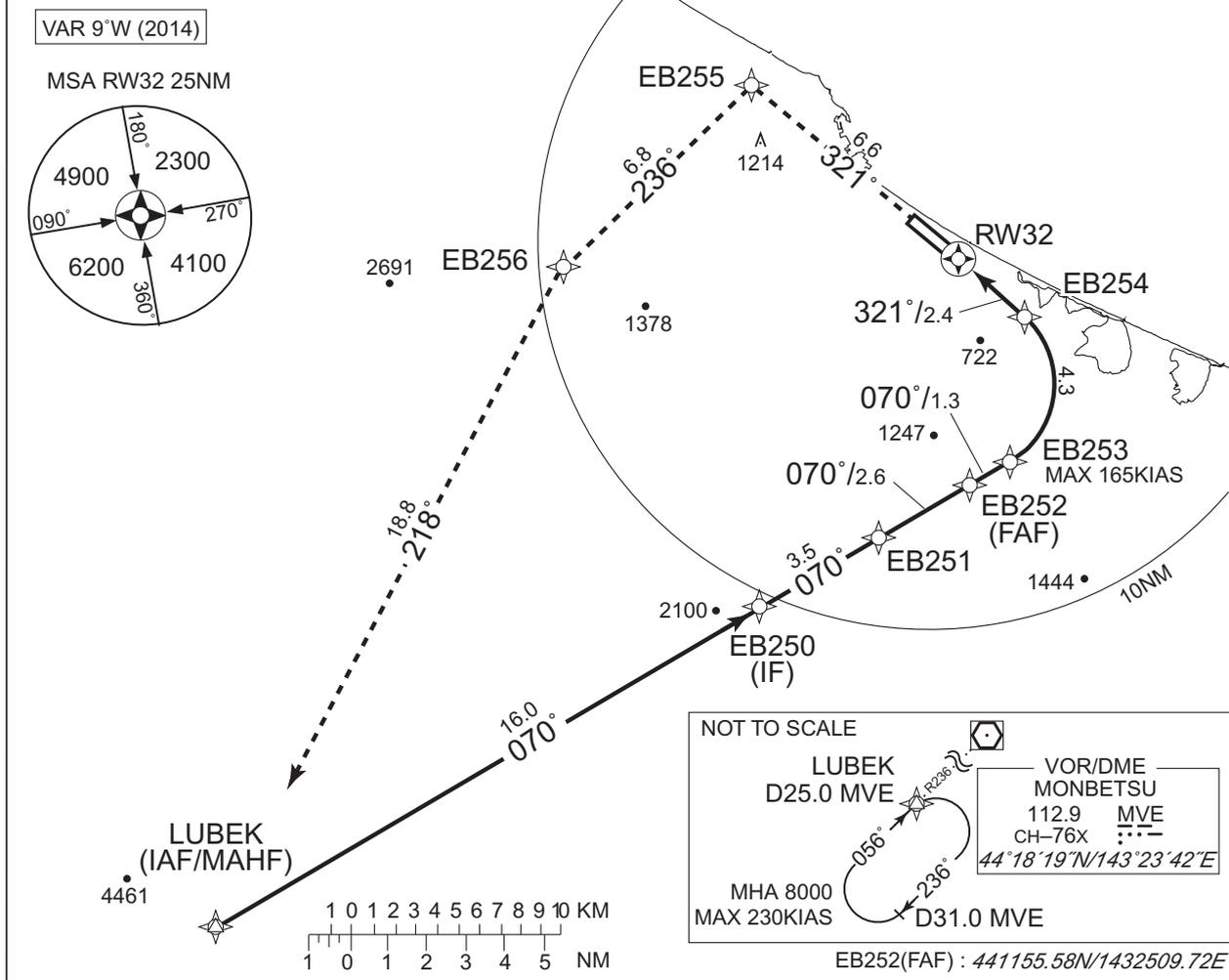

Missed APCH climb gradient MNM 4.0%

MINIMA	THR elev. 72		AD elev. 58	
CAT	RNP 0.14		RNP 0.30	
	DA(H)	RVR/CMV	DA(H)	RVR/CMV
A	—	—	—	—
B	—	—	—	—
C	372 (300)	1000	606 (534)	1200
D		1400		1600

MINIMA with Missed APCH climb gradient of 2.5% are not established.

RNP AR
Special Authorization Required

INSTRUMENT APPROACH CHART

RJEB / MONBETSU

RNAV(RNP) RWY32

RNAV(RNP) RWY32

Coding Table

Serial Number	Path Descriptor	Waypoint Identifier	Fly Over	Course °M(°T)	Magnetic Variation	Distance (NM)	Turn Direction	Altitude (FT)	Speed (KIAS)	VPA/RDH (°/FT)	RNP Value
001	IF	LUBEK	—	—	-9.2	—	—	+8000	—	—	—
002	TF	EB250	—	070 (060.6)	-9.2	16.0	—	+4200	—	—	1.0
003	TF	EB251	—	070 (060.8)	-9.2	3.5	—	+3100	—	—	1.0
004	TF	EB252	—	070 (060.8)	-9.2	2.6	—	2700	—	—	1.0
005	TF	EB253	—	070 (060.9)	-9.2	1.3	—	2282	-165	-3.00	0.14 0.30
006	RF Center: EBRF3 r=2.27NM	EB254	—	—	-9.2	4.3	L	906	—	-3.00	0.14 0.30
007	TF	RW32	Y	321 (312.1)	-9.2	2.4	—	126	—	-3.00/54	0.14 0.30
008	TF	EB255	—	321 (312.0)	-9.2	6.6	—	—	—	—	1.0
009	TF	EB256	—	236 (226.8)	-9.2	6.8	—	—	—	—	1.0
010	TF	LUBEK	—	218 (208.8)	-9.2	18.8	—	8000	—	—	1.0

Waypoint Coordinates

Waypoint Identifier	Coordinates	RF Arc Center Identifier	Coordinates
LUBEK	440108.77N/1425822.82E	EBRF3	441432.89N/1432513.59E
EB250	440857.66N/1431745.13E		
EB251	441039.77N/1432200.05E		
EB252	441155.58N/1432509.72E		
EB253	441233.80N/1432645.48E		
EB254	441614.19N/1432720.26E		
RW32	441752.44N/1432448.06E		
EB255	442218.71N/1431754.45E		
EB256	441739.47N/1431100.00E		

滑走路14末端側進入角指示灯の使用範囲は、障害物（山）のため滑走路14側末端から3.5NM以内とする。

Usable area of PAPI for runway 14 is within 3.5NM from runway 14 threshold due to obstructions (mountain).



ILS

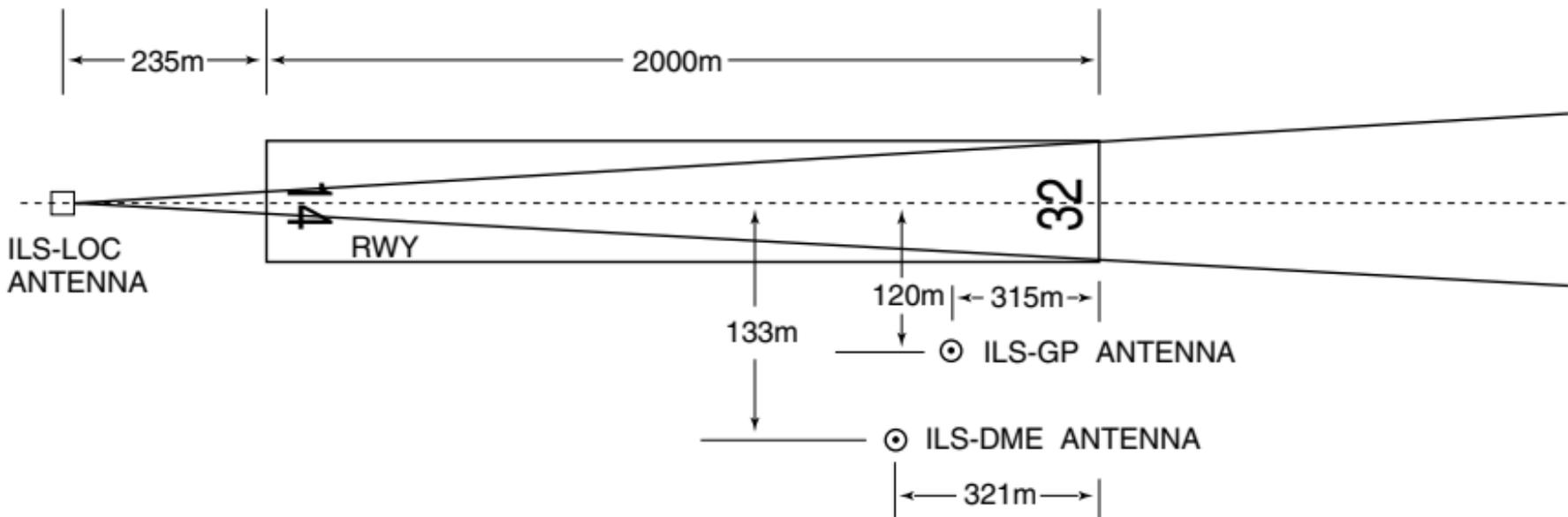

REMARKS : 1. LOC beam BRG(MAG) 321°
2. HGT of ILS REF datum 16.5m(54ft)
3. GP Angle 3.0°
4. ELEV of ILS-DME 26.6m(87ft)

滑走路180° 転回実施要領

1. 滑走路中心線からターニングパッド中心線標識に従って進行する。
2. 転回灯 1 が一直線に見えるように進行し、転回灯 2 が一直線に見えた時転回を開始する。

Procedure of 180° turn on RWY

1. Proceed along the RWY Center Line Marking to the starting point of the RWY Turn Pad Center Line Marking ; then
2. Proceed along the RWY Turn Pad Center Line Marking to see the Turning Point Indicator Light 1 on a straight line, then commence turn at the spot where you (pilot) can see the Turning Point Indicator Light 2 on a straight line at an angle of 9 o'clock.

