

AD 2 AERODROMES

RJCN AD 2.1 AERODROME LOCATION INDICATOR AND NAME

RJCN - NAKASHIBETSU

RJCN AD 2.2 AERODROME GEOGRAPHICAL AND ADMINISTRATIVE DATA

1	ARP coordinates and site at AD	433439N/1445736E 071°/1km from RWY 08 THR
2	Direction and distance from (city)	2nm N NAKASHIBETSU
3	Elevation/ Reference temperature	214ft / 24°C(2004-2008)
4	Geoid undulation at AD ELEV PSN	100ft
5	MAG VAR/ Annual change	9° W(2009) / 2.2'E
6	AD Administration, address, telephone, telefax, telex, AFS, e-mail and/or Web-site addresses	HOKKAIDO. Public AP. Nakashibetsu Airport Administration Office 16-9, Kitanaka, Nakashibetsu-cho, Shibetsu-gun, Hokkaido TEL: 0153-72-2043 FAX: 0153-72-0096 E-mail: kushirodoboku.nakaku1@pref.hokkaido.lg.jp
7	Types of traffic permitted (IFR/VFR)	IFR/VFR
8	Remarks	Nil

RJCN AD 2.3 OPERATIONAL HOURS

1	AD Administration	2330 - 0930
2	Customs and immigration	On request Customs: 0153-25-8257 Immigration: 0154-22-2430
3	Health and sanitation	Quarantine(human): On request(0154-23-3340) Quarantine(animal, plant): Nil
4	AIS Briefing Office	Nil
5	ATS Reporting Office(ARO)	Nil
6	MET Briefing Office	H24 (NEW CHITOSE)
7	ATS	2330 - 0930 Remarks : Airport remote mobile communication service provided by New Chitose FSC
8	Fuelling	2330 - 0930
9	Handling	2330 - 0930
10	Security	2330 - 0930
11	De-icing	Nil
12	Remarks	Nil

RJCN AD 2.4 HANDLING SERVICES AND FACILITIES

1	Cargo-handling facilities	All the modern institutions that deal with the weight thing to a Boeing B767 type freighter
2	Fuel/ oil types	Fuel Grades : JET A-1
3	Fuelling facilities/ capacity	Fuel truck refueling, 19L/sec
4	De-icing facilities	Nil
5	Hangar space for visiting aircraft	Nil
6	Repair facilities for visiting aircraft	Nil
7	Remarks	Nil

RJCN AD 2.5 PASSENGER FACILITIES

1	Hotels	Nil
2	Restaurants	At airport
3	Transportation	Busses and Taxis
4	Medical facilities	Hospital in Nakashibetsu-town, 6km from AP
5	Bank and Post Office	Nil
6	Tourist Office	At airport
7	Remarks	Nil

RJCN AD 2.6 RESCUE AND FIRE FIGHTING SERVICES

1	AD category for fire fighting	CAT 8
2	Rescue equipment	Chemical fire fighting truck x 3, Emergency medical equipments conveyance truck x1
3	Capability for removal of disabled aircraft	Nil
4	Remarks	Nil

RJCN AD 2.7 SEASONAL AVAILABILITY-CLEARING

1	Types of clearing equipment	Snow removal equipments: 19
2	Clearance priorities	(1) RWY 08/26, TWY, APRON
3	Remarks	Nil

RJCN AD 2.8 APRONS, TAXIWAYS AND CHECK LOCATIONS DATA

1	Apron surface and strength	Surface : Concrete Strength : PCN 48/R/B/X/T
2	Taxiway width, surface and strength	Width : 30m Surface : Asphalt-concrete Strength : PCN 57/F/C/X/T
3	ACL and elevation	Not available
4	VOR checkpoints	Not available
5	INS checkpoints	Spot NR 1: 433423.88N, 1445719.30E 2: 433424.51N, 1445721.83E 3: 433425.06N, 1445724.04E
6	Remarks	Nil

RJCN AD 2.9 SURFACE MOVEMENT GUIDANCE AND CONTROL SYSTEM AND MARKINGS

1	Use of aircraft stand ID signs, TWY guide lines and Visual docking/ parking guidance system of aircraft stands	Aircraft stand ID signs: Nil ACFT stand taxi lane marking: See AD2.24 AD Chart Visual docking guidance system: Nil
2	RWY and TWY markings and LGT	RWY: RWY 08/26 (Marking): RWY designation, RWY CL, RWY side stripe, RWY THR, TDZ, Aiming point, RWY turn pad CL, RWY turn pad edge. (LGT): RCLL, REDL, RTHL, RENL, RTZL(RWY08), WBAR(RWY08), Turning point indicator LGT, RWY DIST marker LGT TWY: (Marking): TWY CL, TWY side stripe, RWY HLDG PSN (LGT): TWY edge LGT, TWY CL LGT
3	Stop bars	Nil
4	Remarks	(Marking)Overrun area, Apron TWY CL (LGT)Apron flood LGT

180° turn on RWY

B-767型機用の滑走路180° 転回実施要項

1. 滑走路中心線からターニングパッド中心線標識に従って進行する。
2. 転回灯1が一直線に見えるように進行し，転回灯2が一直線に見えた時転回を開始する。

Procedure of 180° turn on RWY for B-767 aircraft

1. Proceed along the RWY Center Line Marking to the starting point of the RWY Turn Pad Center Line Marking ; then
2. Proceed along the RWY Turn Pad Center Line Marking to see the Turning Point Indicator Light 1 on a straight line, then commence turn at the spot where you (pilot) can see the Turning Point Indicator Light 2 on a straight line at an angle of 9 o'clock.

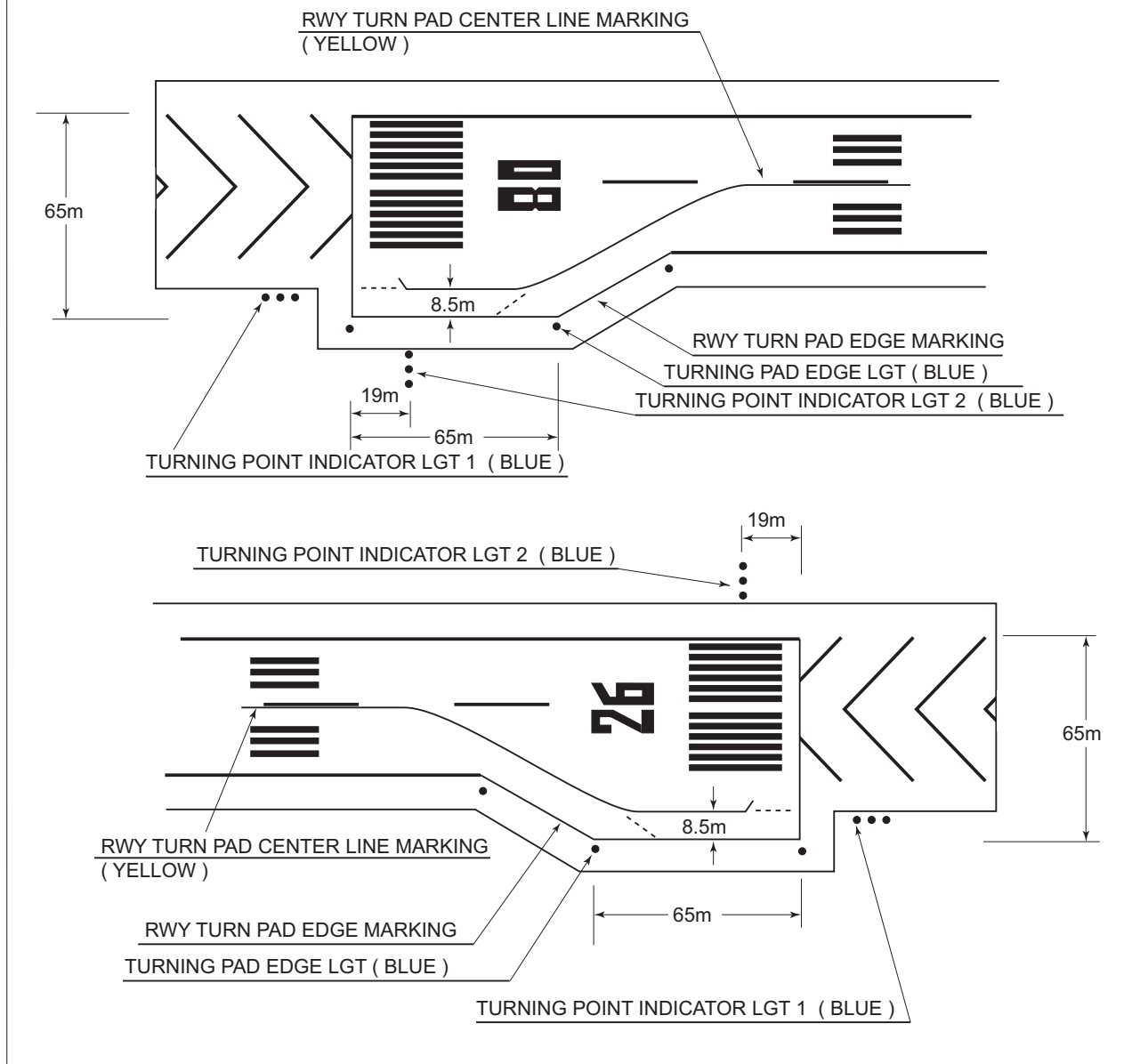

RJCN AD 2.10 AERODROME OBSTACLES

In approach/TKOF areas

RWY/Area affected	Obstacle type	Coordinates	Elevation	Markings/ LGT	Remarks
RWY08	Building	433426.9N/1445614.6E	282ft	-/LIL	Nil
RWY26	Tower	433449.9N/1445839.7E	233ft	-/LIL	Nil

In circling area and at AD

Obstacle type	Coordinates	Elevation	Markings/ LGT	Remarks
Nil				

RJCN AD 2.11 METEOROLOGICAL INFORMATION PROVIDED

1	Associated MET Office	NEW CHITOSE
2	Hours of service MET Office outside hours	H24 (NEW CHITOSE)
3	Office responsible for TAF preparation Periods of validity	Nil
4	Trend forecast Interval of issuance	Nil
5	Briefing/ consultation provided	Briefing is available upon inquiry at NEW CHITOSE
6	Flight documentation Language(s) used	C En
7	Charts and other information available for briefing or consultation	S ₆ , U ₈₅ , U ₇ , U ₅ , U ₃ , U ₂₅ , U ₂ /T _r , P _S , P ₅ , P ₃ , P ₂₅ , P _{SWE} , P _{SWF} , P _{SWG} , P _{SWI} , P _{SWM} , P _{SW} (domestic), E, C, W _E , W _F , W _G , W _I , W, N
8	Supplementary equipment available for providing information	Nil
9	ATS units provided with information	REMOTE
10	Additional information (limitation of service, etc.)	Nil

RJCN AD 2.12 RUNWAY PHYSICAL CHARACTERISTICS

Designations RWY NR	TRUE BRG	Dimensions of RWY(M)	Strength(PCN) and surface of RWY	THR coordinates THR geoid undulation	THR elevation and highest elevation of TDZ of precision APP RWY
1	2	3	4	5	6
08	071.02°	2000x45	PCN 57/F/C/X/T Asphalt-concrete	433428.20N 1445653.10E 100.4ft	THR ELEV: 233.4FT TDZ ELEV: 230.5FT
26	251.02°	2000x45	PCN 57/F/C/X/T PCN 53/F/B/X/T(*1) Asphalt-concrete	433449.27N 1445817.40E 100ft	THR ELEV: 212FT
Slope of RWY		Strip Dimensions(M)	RESA(Overrun) Dimensions(M)		Remarks
7	10	11	14		
See below figure		2120x300 2120x300	190x(MNM:136 MAX:300)* 40x300 *For detail, ask airport administrator		RWY Grooving:2000x45m (*1)First 200m of RWY 26

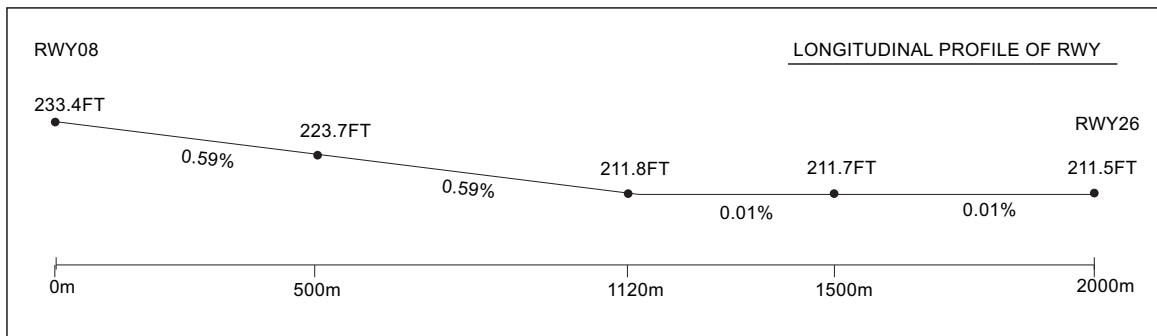

RJCN AD 2.13 DECLARED DISTANCES

RWY Designator	TORA (m)	TODA (m)	ASDA (m)	LDA (m)	Remarks
1	2	3	4	5	6
08	2000	2000	2000	2000	Nil
26	2000	2000	2000	2000	Nil

RJCN AD 2.14 APPROACH AND RUNWAY LIGHTING

RWY Designator	APCH LGT type LEN INTST	RTHL Color WBAR	PAPI (VASIS) Angle DIST FM THR MEHT	RTZL LEN	RCLL LEN Spacing Color INTST	REDL LEN Spacing Color INTST	RENL Color WBAR	STWL LEN Color
1	2	3	4	5	6	7	8	9
08	PALS (CAT I) 900m LIH	Green Green	PAPI 3.0°/Left 444m 60.4ft	900m	2000m 30m Coded color (White/Red) LIH	2000m 60m Coded color (White/Yellow) LIH	Red	Nil(*1)
26	SALS (*2) 420m LIH	Green -	PAPI 3.0°/Left 378m 61ft	-	2000m 30m Coded color (White/Red) LIH	2000m 60m Coded color (White/Yellow) LIH	Red	Nil(*1)
Remarks								
10								
Overrun area edge LGT(LEN:60m Color:Red)(*1) SALS with APCH LGT beacon(585m and 900m FM RWY THR)(*2)								

RJCN AD 2.15 OTHER LIGHTING, SECONDARY POWER SUPPLY

1	ABN/IBN location, characteristics and hours of operation	ABN: 433423N /1445745E, ALTN FLG(2)WG EV 4.3SEC, HO
2	LDI location and LGT Anemometer location and LGT	LDI:Nil Anemometer: RWY08:331m from RWY 08 THR, LGTD RWY26:513m from RWY 26 THR, LGTD
3	TWY edge and center line lighting	TWY edge and center line lights installed, see AD 2.9
4	Secondary power supply/ switch-over time	Within 1sec : REDL, RENL, RTHL, WBAR, RCLL, Turning point indicator LGT, Overrun area edge LGT Within 15sec : Other LGT
5	Remarks	WDI LGT

RJCN AD 2.16 HELICOPTER LANDING AREA

Nil

RJCN AD 2.17 ATS AIRSPACE

Designation and lateral limits		Vertical limits (ft)	Airspace classification	ATS unit call sign Language	Remarks
1		2	3	4	6
Nakashibetsu Information Zone	Area within a radius of 5NM(9km) of Nakashibetsu ARP	3000	E	Nakashibetsu Remote En	

RJCN AD 2.18 ATS COMMUNICATION FACILITIES

Service designation	Call sign	Frequency	Hours of operation	Remarks
1	2	3	4	5
A/G	Nakashibetsu Remote	122.7MHz	2330 - 0930	Remote air-ground facility controlled by New Chitose FSC.

RJCN AD 2.19 RADIO NAVIGATION AND LANDING AIDS

Type of aid (VOR declination)	ID	Frequency	Hours of operation	Position of transmitting antenna coordinates	Elevation of DME transmitting antenna	Remarks
1	2	3	4	5	6	7
VOR (9°W/2019)	NSE	111.45MHz	2330 - 0930	433438.50N/ 1445701.81E		VOR Unusable: 290°-300° beyond 30nm BLW 6000ft. 300°-310° beyond 25nm BLW 6000ft. 310°-320° beyond 30nm BLW 8000ft. 320°-340° beyond 25nm BLW 8000ft. 340°-350° beyond 20nm BLW 8000ft. 350°-010° beyond 30nm BLW 8000ft.
DME	NSE	1138MHz (CH-51Y)	2330 - 0930	433438.50N/ 1445701.81E	264ft	DME Unusable: 280°-300° beyond 30nm BLW 6000ft. 300°-310° beyond 25nm BLW 6000ft. 310°-320° beyond 30nm BLW 8000ft. 320°-340° beyond 25nm BLW 8000ft. 340°-350° beyond 15nm BLW 8000ft. 350°-010° beyond 30nm BLW 8000ft.
ILS-LOC 08	INS	109.35MHz	2330 - 0930	433451.74N/ 1445827.27E		LOC : 235m(771ft) away FM RWY 26 THR, BRG(MAG)080°.
ILS-GP 08	-	331.85MHz	2330 - 0930	433428.13N/ 1445709.91E		GP : 356m (1168ft) inside FM RWY 08 THR, 125m(410ft)S of RCL. Angle 3.0°, HGT of ILS Ref datum 16.5m (54ft).
ILS-DME	INS	1117MHz (CH-30Y)	2330 - 0930	433428.14N/ 1445710.30E	242ft	DME : 364.8m(1197ft) inside FM RWY 08 THR, 127.5m(418ft) S of RCL.
MSAS		1575.42MHz	H24			Transmitting antennas are satellite based.

ILS

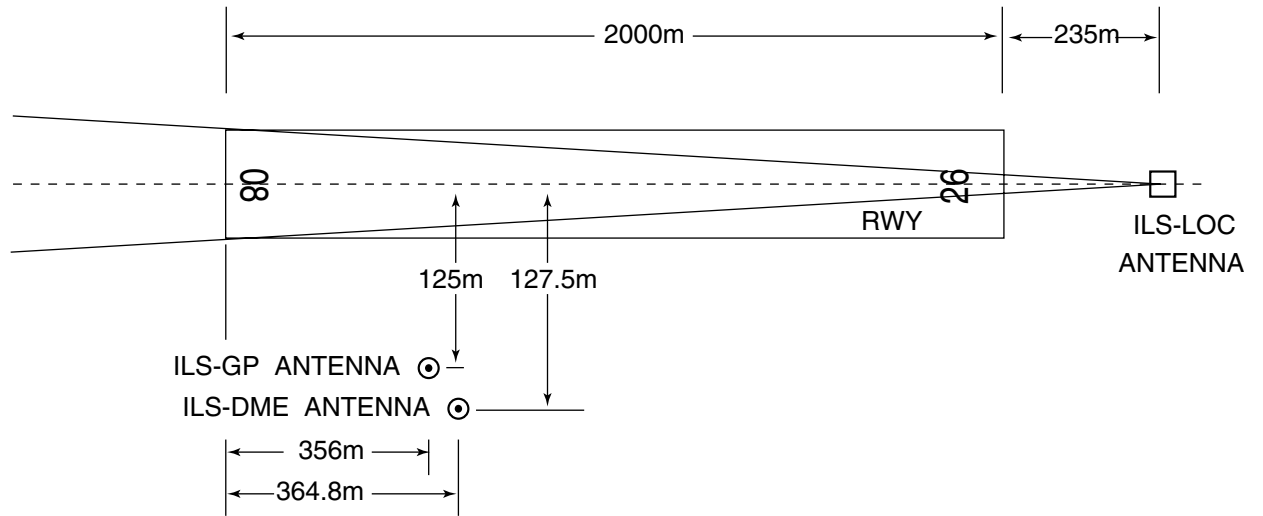

- REMARKS :
- | | |
|-------------------------|--------------|
| 1. LOC beam BRG (MAG) | 080° |
| 2. GP Angle | 3.0° |
| 3. HGT of ILS REF datum | 16.5m(54 ft) |
| 4. ELEV of ILS-DME | 73.6m(242ft) |

RJCN AD 2.20 LOCAL TRAFFIC REGULATIONS

1. Airport regulations

Nil

2. Taxiing to and from stands

Nil

3. Parking area for small aircraft(General aviation)

Nil

4. Parking area for helicopters

Nil

5. Apron - taxiing during winter conditions

Nil

6. Taxiing - limitations

Nil

7. School and training flights - technical test flights - use of runways

Nil

8. Helicopter traffic - limitation

Nil

9. Removal of disabled aircraft from runways

Nil

RJCN AD 2.21 NOISE ABATEMENT PROCEDURES

Nil

RJCN AD 2.22 FLIGHT PROCEDURES

TAKE OFF MINIMA

	RWY	ACFT CAT	REDL & RCLL		REDL or RCLL or RCL Marking		NIL (DAYTIME ONLY)	
			RVR	VIS	RVR	VIS	RVR	VIS
Multi-Engine ACFT with TKOF ALTN AP FILED	08	A,B,C,D	400m	400m	400m	400m	-	500m
	26	A,B,C,D	-	400m	-	400m	-	500m
OTHER	08	A,B,C,D	AVBL LDG MINIMA					
	26	A,B,C,D						

RJCN AD 2.23 ADDITIONAL INFORMATION

Nil

RJCN AD 2.24 CHARTS RELATED TO AN AERODROME

- Aerodrome/Heliport Chart
- Standard Departure Chart - Instrument (MASHU, NAKASHIBETSU REVERSAL)
- Standard Departure Chart - Instrument (TSURUI, KIRITAPPU-RNAV)
- Standard Arrival Chart - Instrument (KUSHIRO-RNAV)
- Instrument Approach Chart (ILS Z or LOC Z RWY08)
- Instrument Approach Chart (ILS Y or LOC Y RWY08)
- Instrument Approach Chart (VOR RWY08)
- Instrument Approach Chart (VOR RWY26)
- Instrument Approach Chart (RNAV(RNP) Z RWY26)
- Instrument Approach Chart (RNAV(RNP) Y RWY26)
- Other Chart (Visual REP)
- Other Chart (LDG CHART)
- Other Chart (MVA CHART)

INTENTIONALLY LEFT BLANK

RJCN / NAKASHIBETSU

AD CHART

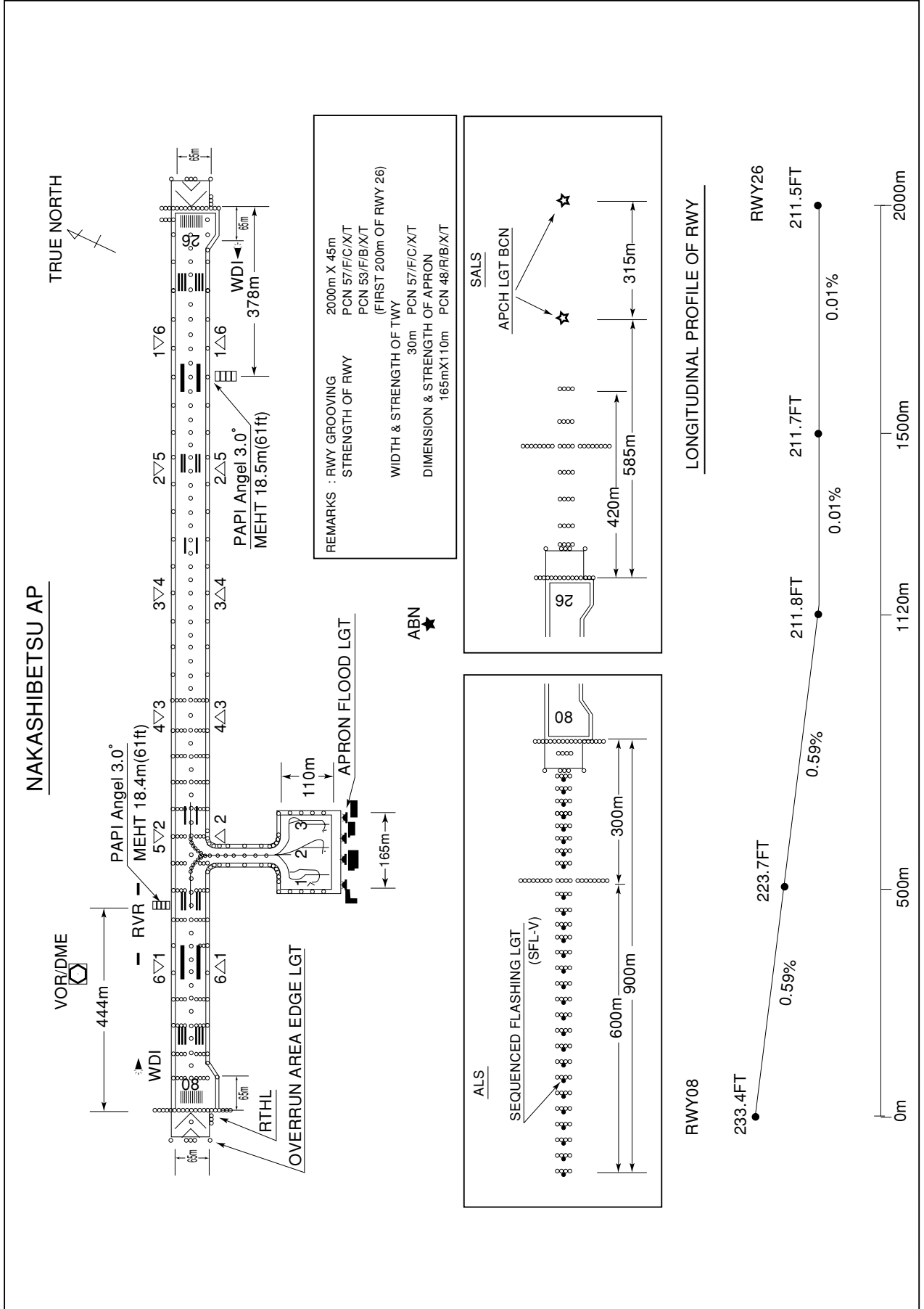

RJCN / NAKASHIBETSU

Minimum Vectoring Altitude CHART

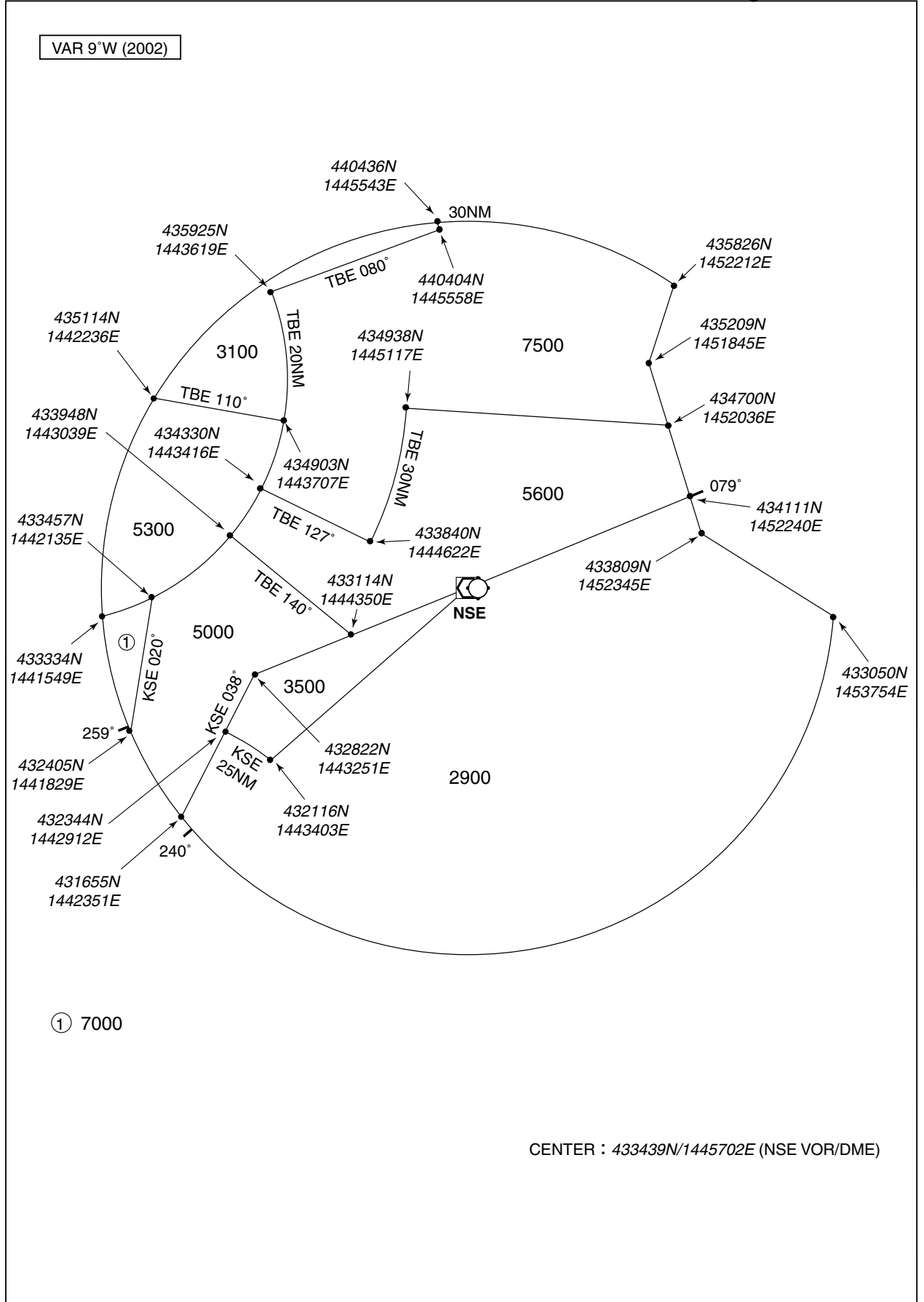

STANDARD DEPARTURE CHART-INSTRUMENT

RJCN / NAKASHIBETSU

RNAV SID

TSURUI ONE DEPARTURE	Basic RNP1
----------------------	------------

Note GNSS required.

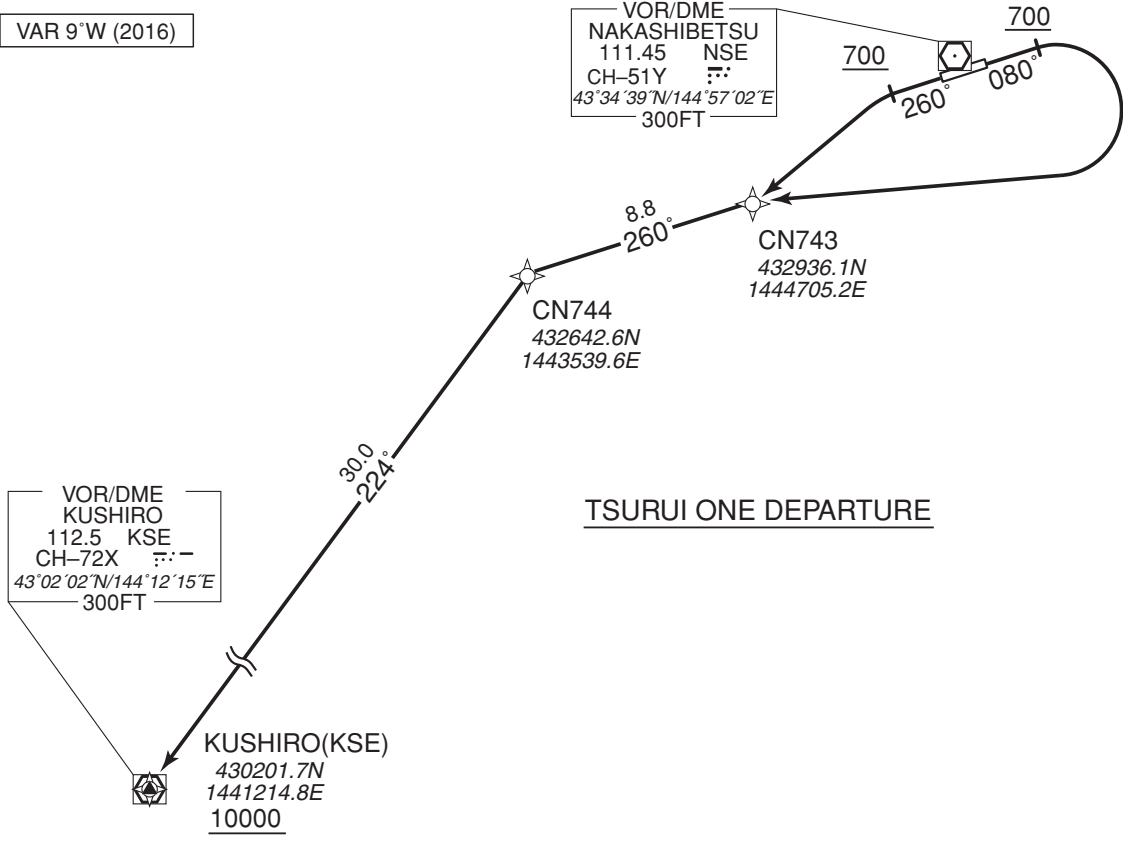

TSURUI ONE DEPARTURE

RWY08 : Climb on HDG080° at or above 700FT, turn right direct to CN743, to CN744, to KSE at or above 10000FT.
 RWY26 : Climb on HDG260° at or above 700FT, turn left direct to CN743, to CN744, to KSE at or above 10000FT.

RWY08

Serial Number	Path Descriptor	Waypoint Identifier	Fly Over	Course °M(°T)	Magnetic Variation	Distance (NM)	Turn Direction	Altitude (FT)	Speed (KIAS)	Vertical Angle	Navigation Specification
001	VA	-	-	080 (071.0)	-8.9	-	-	+700	-	-	Basic RNP1
002	DF	CN743	-	-	-8.9	-	R	-	-	-	Basic RNP1
003	TF	CN744	-	260 (250.8)	-8.9	8.8	-	-	-	-	Basic RNP1
004	TF	KSE	-	224 (214.8)	-8.9	30.0	-	+10000	-	-	Basic RNP1

RWY26

Serial Number	Path Descriptor	Waypoint Identifier	Fly Over	Course °M(°T)	Magnetic Variation	Distance (NM)	Turn Direction	Altitude (FT)	Speed (KIAS)	Vertical Angle	Navigation Specification
001	VA	-	-	260 (251.0)	-8.9	-	-	+700	-	-	Basic RNP1
002	DF	CN743	-	-	-8.9	-	L	-	-	-	Basic RNP1
003	TF	CN744	-	260 (250.8)	-8.9	8.8	-	-	-	-	Basic RNP1
004	TF	KSE	-	224 (214.8)	-8.9	30.0	-	+10000	-	-	Basic RNP1

STANDARD DEPARTURE CHART-INSTRUMENT

RJCN / NAKASHIBETSU

RNAV SID

KIRITAPPU ONE DEPARTURE

Basic RNP1

Note GNSS required.

VAR 9°W (2016)

VOR/DME
NAKASHIBETSU
111.45 NSE
CH-51Y
43°34'39"N/144°57'02"E
300FT

VOR/DME
KUSHIRO
112.5 KSE
CH-72X
43°02'02"N/144°12'15"E
300FT

KUSHIRO(KSE)
430201.7N
1441214.8E
10000



KIRITAPPU ONE DEPARTURE

KIRITAPPU ONE DEPARTURE

RWY08 : Climb on HDG080° at or above 700FT, turn right direct to BEKKA, to CN742, to KSE at or above 10000FT.

RWY26 : Climb on HDG260° at or above 700FT, turn left direct to BEKKA, to CN742, to KSE at or above 10000FT.

RWY08

Serial Number	Path Descriptor	Waypoint Identifier	Fly Over	Course °M(°T)	Magnetic Variation	Distance (NM)	Turn Direction	Altitude (FT)	Speed (KIAS)	Vertical Angle	Navigation Specification
001	VA	-	-	080 (071.0)	-8.9	-	-	+700	-	-	Basic RNP1
002	DF	BEKKA	-	-	-8.9	-	R	-	-	-	Basic RNP1
003	TF	CN742	-	188 (179.0)	-8.9	16.6	-	-	-	-	Basic RNP1
004	TF	KSE	-	273 (263.7)	-8.9	44.3	-	+10000	-	-	Basic RNP1

RWY26

Serial Number	Path Descriptor	Waypoint Identifier	Fly Over	Course °M(°T)	Magnetic Variation	Distance (NM)	Turn Direction	Altitude (FT)	Speed (KIAS)	Vertical Angle	Navigation Specification
001	VA	-	-	260 (251.0)	-8.9	-	-	+700	-	-	Basic RNP1
002	DF	BEKKA	-	-	-8.9	-	L	-	-	-	Basic RNP1
003	TF	CN742	-	188 (179.0)	-8.9	16.6	-	-	-	-	Basic RNP1
004	TF	KSE	-	273 (263.7)	-8.9	44.3	-	+10000	-	-	Basic RNP1

CHANGE: Marginal note (Title)

STANDARD ARRIVAL CHART - INSTRUMENT

RJCN / NAKASHIBETSU

RNAV STAR

KUSHIRO ARRIVAL

Basic RNP1

Note GNSS required.

VAR 9°W (2016)

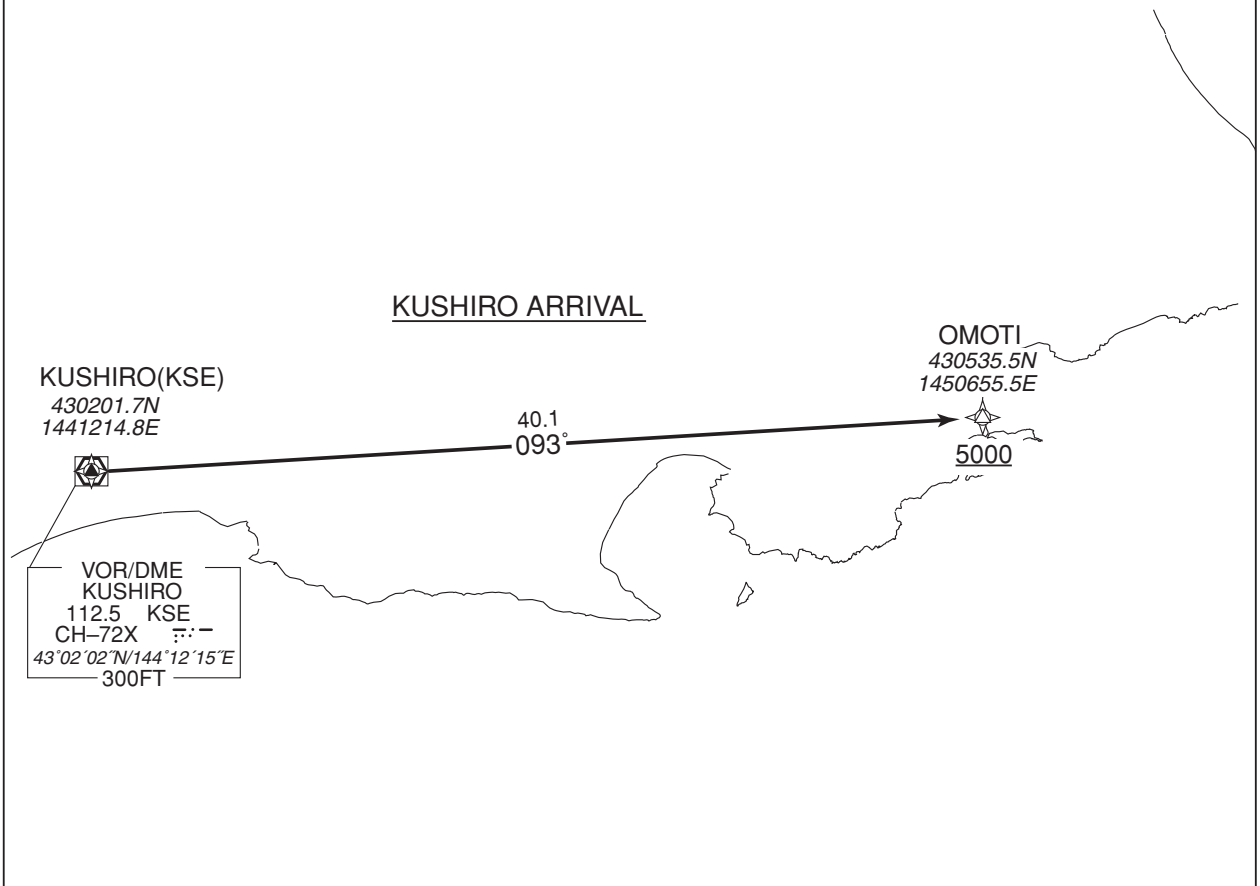

KUSHIRO ARRIVAL

From KSE, to OMOTI at or above 5000FT.

Serial Number	Path Descriptor	Waypoint Identifier	Fly Over	Course °M(°T)	Magnetic Variation	Distance (NM)	Turn Direction	Altitude (FT)	Speed (KIAS)	Vertical Angle	Navigation Specification
001	IF	KSE	-	-	-8.9	-	-	-	-	-	Basic RNP1
002	TF	OMOTI	-	093 (084.6)	-8.9	40.1	-	+5000	-	-	Basic RNP1

INSTRUMENT APPROACH CHART

RJCN / NAKASHIBETSU

RNAV(RNP) Z RWY26

SAPPORO CONTROL 128.325 – 246.1 134.25 – 260.4	GNSS and RF required.	NAKASHIBETSU REMOTE 122.7	NO RADAR
--	-----------------------	------------------------------	----------

For uncompensated Baro-VNAV systems, procedure not authorized below -30°C / above 45°C

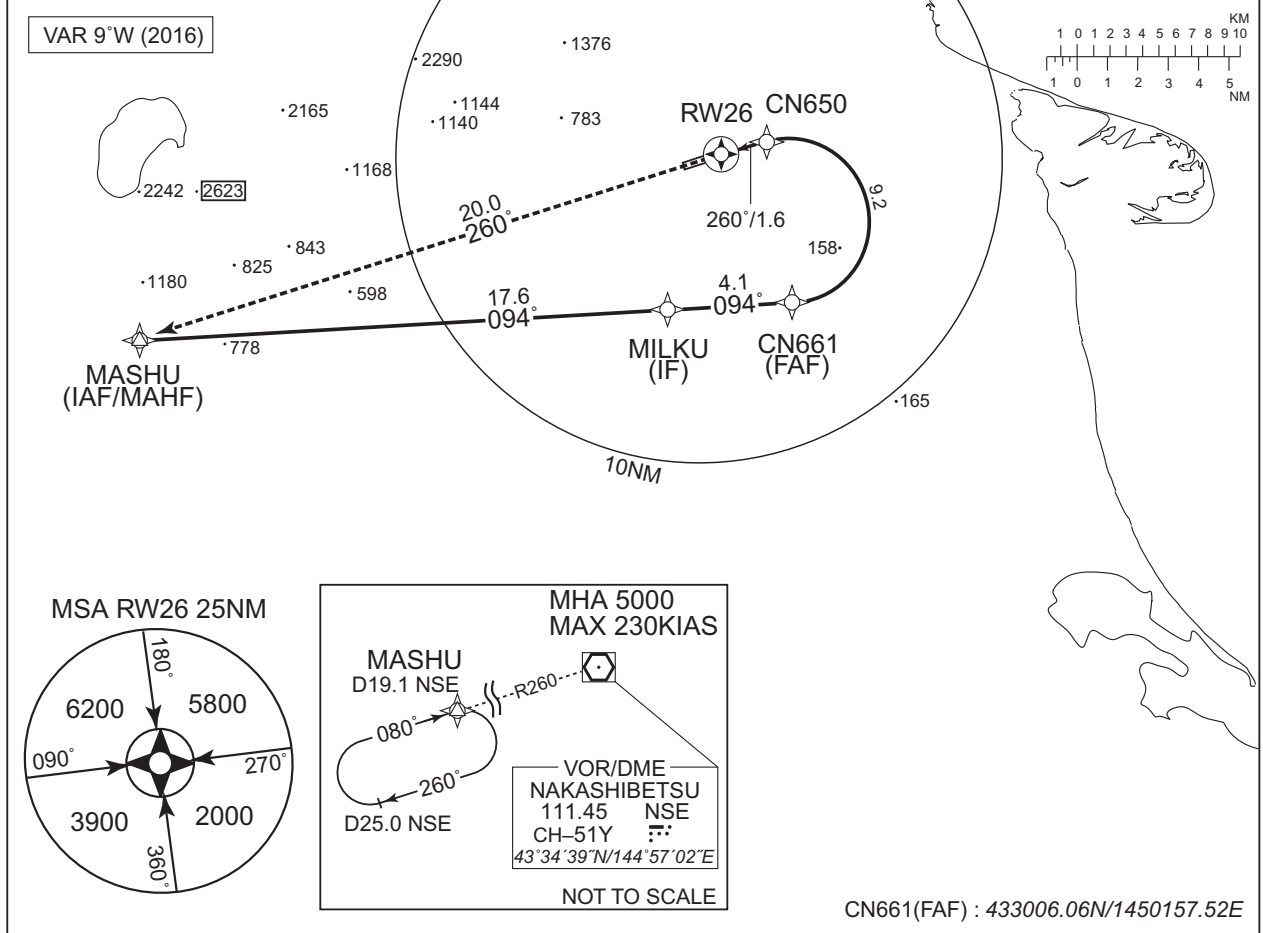

CHANGE : Radial FM NSE. Bearing on HOLD Pattern .

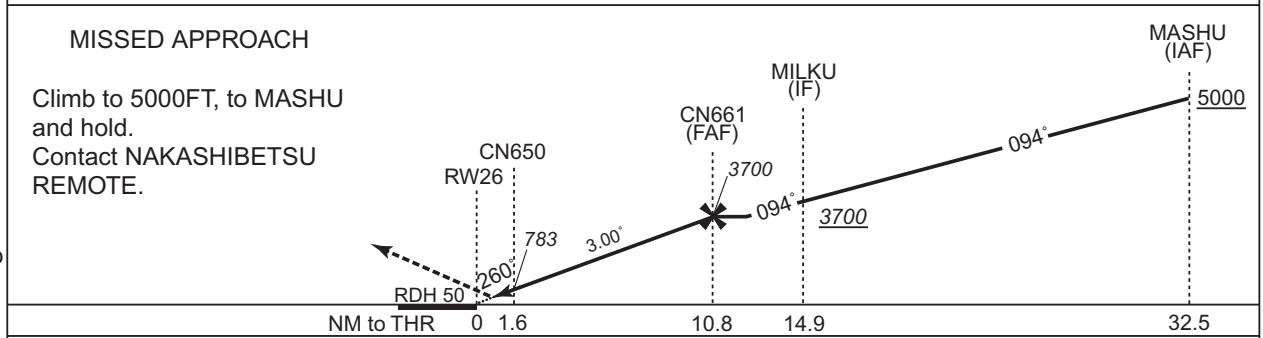

MINIMA	THR elev.212	AD elev.214
RNP 0.30		
CAT	DA(H)	CMV
A	-	-
B	-	-
C	512 (300)	1400
D		1600

RNP AR
Special Authorization Required

INSTRUMENT APPROACH CHART

RJCN / NAKASHIBETSU

RNAV(RNP) Z RWY26

RNAV(RNP) Z RWY26Coding Table

Serial Number	Path Descriptor	Waypoint Identifier	Fly Over	Course °M(°T)	Magnetic Variation	Distance (NM)	Turn Direction	Altitude (FT)	Speed (KIAS)	VPA/RDH (°/FT)	RNP Value
001	IF	MASHU	–	–	-8.9	–	–	+5000	–	–	–
002	TF	MILKU	–	094 (084.9)	-8.9	17.6	–	+3700	–	–	1.0
003	TF	CN661	–	094 (085.2)	-8.9	4.1	–	3700	–	–	1.0
004	RF Center: CNRF2 r=2.70NM	CN650	–	–	-8.9	9.2	L	783	–	-3.00	0.3
005	TF	RW26	Y	260 (251.0)	-8.9	1.6	–	262	–	-3.00/50	0.3
006	TF	MASHU	–	260 (251.0)	-8.9	20.0	–	5000	–	–	1.0

Waypoint Coordinates

Waypoint Identifier	Coordinates	RF Arc Center Identifier	Coordinates
MASHU	432815.18N/1443214.49E	CNRF2	433247.93N/1450139.17E
MILKU	432945.72N/1445620.67E		
CN661	433006.06N/1450157.52E		
CN650	433521.30N/1450025.71E		
RW26	433449.27N/1445817.40E		

INSTRUMENT APPROACH CHART

RJCN / NAKASHIBETSU

RNAV(RNP) Y RWY26

SAPPORO CONTROL 128.325 – 246.1 134.25 – 260.4	GNSS and RF required.	NAKASHIBETSU REMOTE 122.7	NO RADAR
--	-----------------------	------------------------------	----------

For uncompensated Baro-VNAV systems, procedure not authorized below -30°C / above 45°C

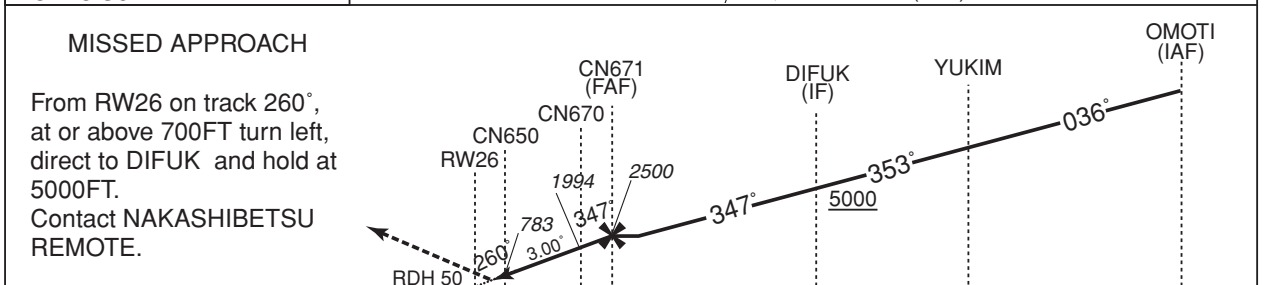
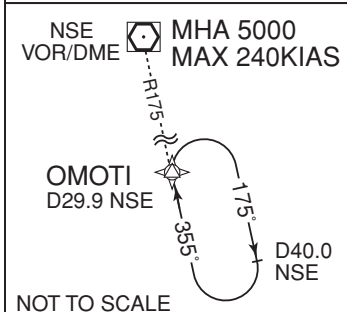
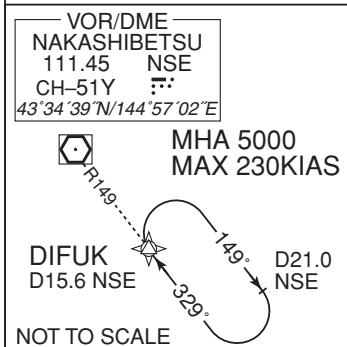
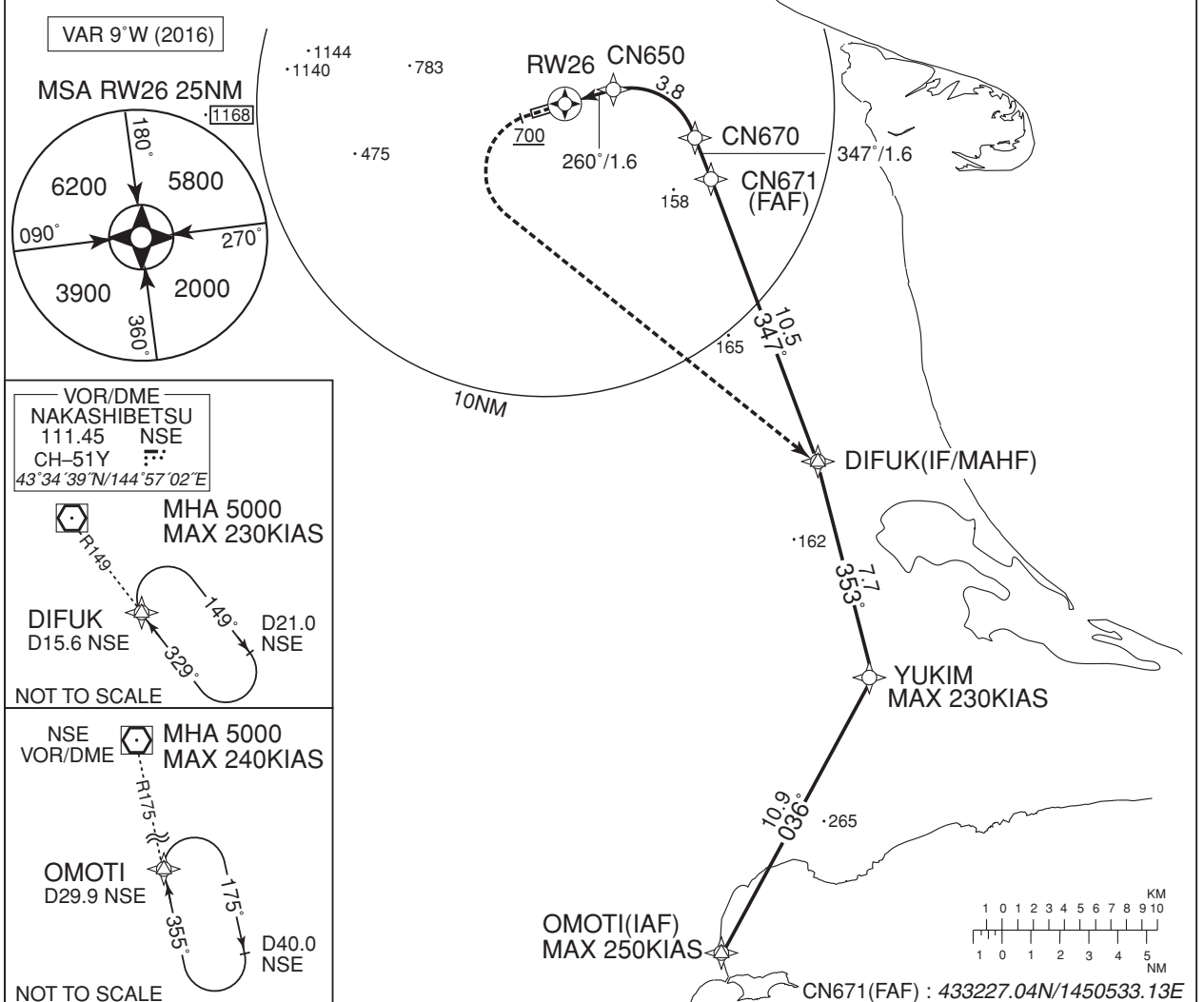

MISSED APPROACH

From RWY26 on track 260°, at or above 700FT turn left, direct to DIFUK and hold at 5000FT. Contact NAKASHIBETSU REMOTE.

MINIMA THR elev.212 AD elev.214

CAT	RNP 0.30	
	DA(H)	CMV
A	-	-
B	-	-
C	512 (300)	1400
D		1600

MINIMA with Missed APCH climb gradient of 2.5% are not established.

RNP AR
Special Authorization Required

INSTRUMENT APPROACH CHART

RJCN / NAKASHIBETSU

RNAV(RNP) Y RWY26

RNAV(RNP) Y RWY26

Coding Table

Serial Number	Path Descriptor	Waypoint Identifier	Fly Over	Course °M(°T)	Magnetic Variation	Distance (NM)	Turn Direction	Altitude (FT)	Speed (KIAS)	VPA/RDH (°/FT)	RNP Value
001	IF	OMOTI	-	-	-8.9	-	-	+5000	-250	-	-
002	TF	YUKIM	-	036 (027.2)	-8.9	10.9	-	+5000	-230	-	1.0
003	TF	DIFUK	-	353 (344.3)	-8.9	7.7	-	+5000	-	-	1.0
004	TF	CN671	-	347 (338.4)	-8.9	10.5	-	2500	-	-	1.0
005	TF	CN670	-	347 (338.3)	-8.9	1.6	-	1994	-	-3.00	0.3
006	RF Center: CNRF1 r=2.50NM	CN650	-	-	-8.9	3.8	L	783	-	-3.00	0.3
007	TF	RW26	Y	260 (251.0)	-8.9	1.6	-	262	-	-3.00/50	0.3
008	FA	-	-	260 (251.0)	-8.9	-	-	+700	-	-	1.0
009	DF	DIFUK	-	-	-8.9	-	L	5000	-	-	1.0

Waypoint Coordinates

Waypoint Identifier	Coordinates	RF Arc Center Identifier	Coordinates
OMOTI	430535.54N/1450655.47E	CNRF1	433259.00N/1450132.84E
YUKIM	431516.17N/1451345.84E		
DIFUK	432242.79N/1451052.79E		
CN671	433227.04N/1450533.13E		
CN670	433354.84N/1450444.93E		
CN650	433521.30N/1450025.71E		
RW26	433449.27N/1445817.40E		

STANDARD DEPARTURE CHART-INSTRUMENT

RJCN / NAKASHIBETSU

SID

MASHU FIVE DEPARTURE

RWY08: Climb RWY HDG to 700FT, turn right HDG305° to intercept and proceed...

RWY26: Climb...

... via NSE R260 to MASHU.

Cross MASHU at or above 5000FT.

CHANGE : PROC renamed.Radial FM NSE .

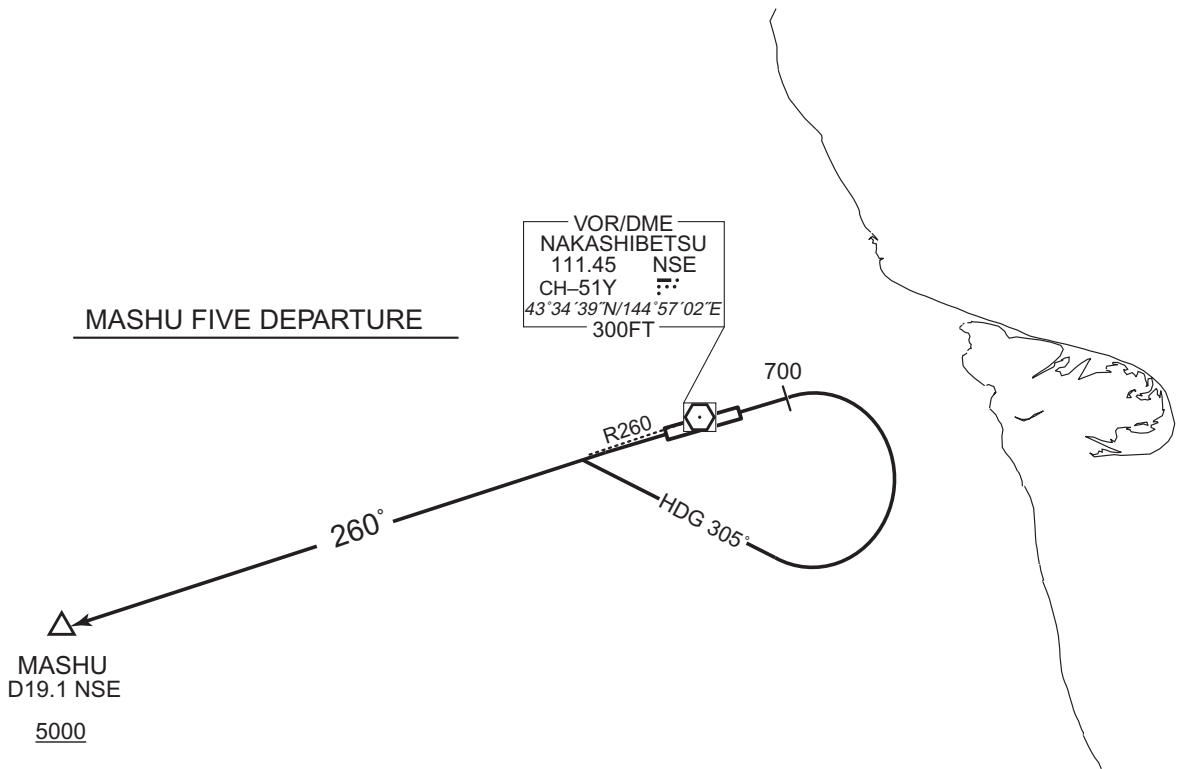

STANDARD DEPARTURE CHART-INSTRUMENT

RJCN / NAKASHIBETSU

SID

NAKASHIBETSU REVERSAL FOUR DEPARTURE

RWY08: Climb via NSE R081 to NSE 7.0DME, turn right,...

RWY26: Climb via NSE R259 to NSE 7.0DME, turn left,...

... direct to NSE VOR/DME.

NAKASHIBETSU REVERSAL FOUR DEPARTURE

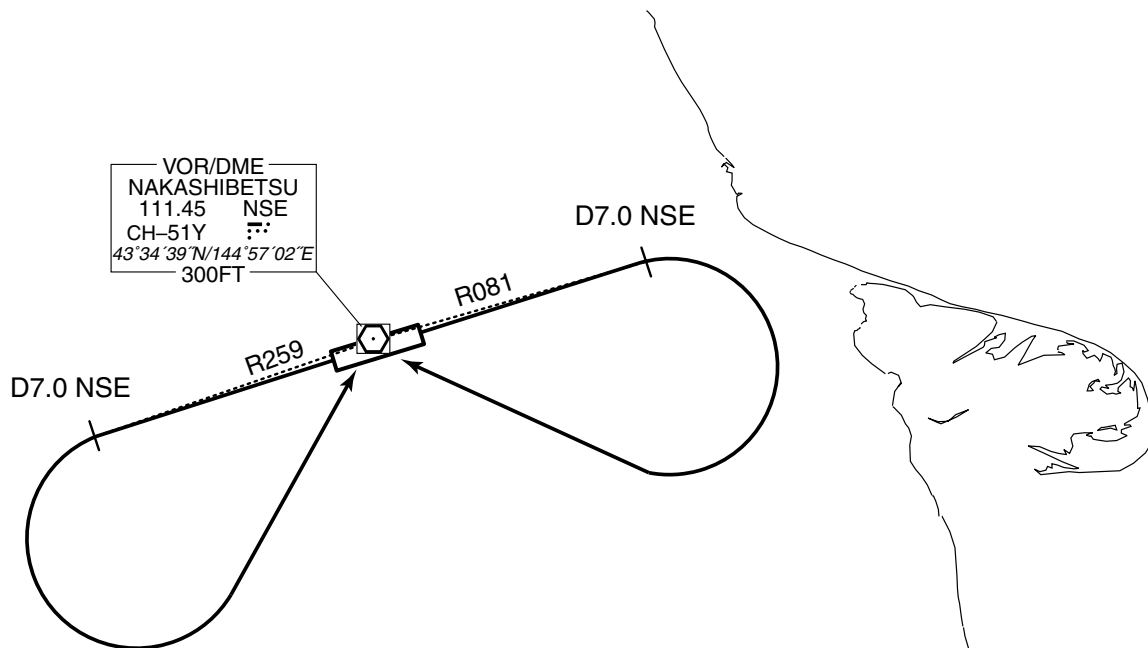

INSTRUMENT APPROACH CHART

RJCN / NAKASHIBETSU ILS Z or LOC Z RWY08

SAPPORO CONTROL 128.325 – 246.1 134.25 – 260.4	ILS / LOC 109.35 INS :: ILS - GP 331.85 ILS-DME CH-30Y	NAKASHIBETSU REMOTE 122.7	NO RADAR
--	---	----------------------------------	----------

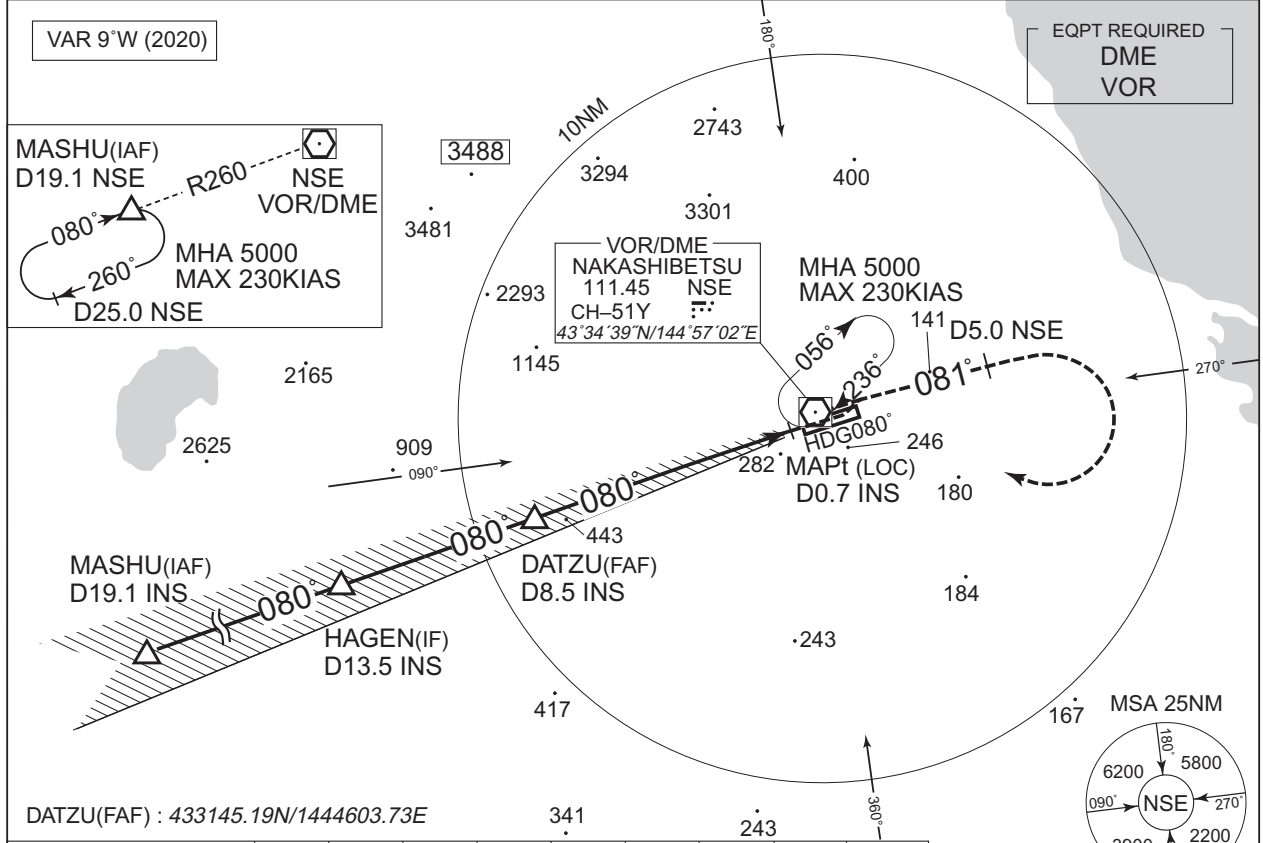

NM to INS	FAF	8	7	6	5	4	3	2	MAPt
ALT (3.0° APCH Path)	2934	2767	2449	2130	1812	1494	1175	856	-

CHANGE : VAR. Radial FM NSE. Bearing on HOLD Pattern.

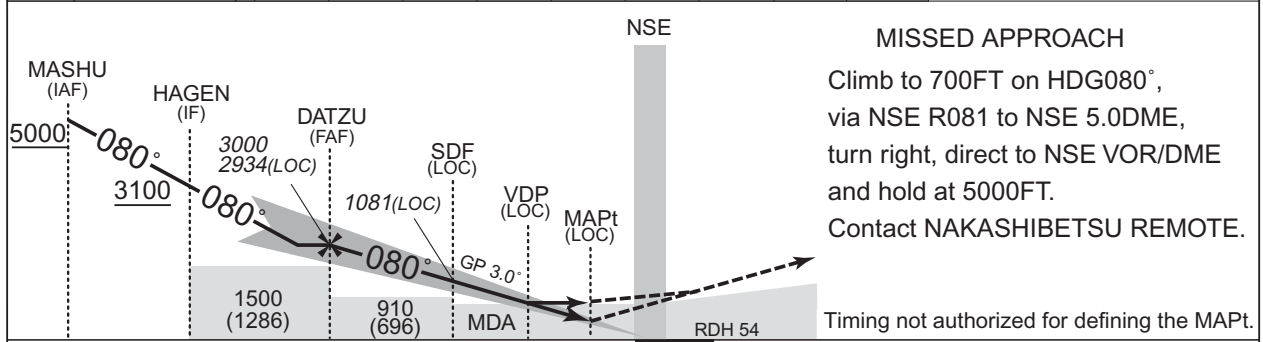

19.1	13.5	8.5	2.6	1.4	0.7	0.2	DME to INS
18.9	13.3	8.3	2.5	1.2	0.5	0	NM to THR

MINIMA			THR elev. 233		AD elev. 214		
CAT	CAT I		LOC		CIRCLING		
	DA(H)	RVR/CMV	MDA(H)	RVR/CMV	MDA(H)	VIS	
A	433 (200)	550	640 (426)	900	690 (476)	1600	
B				1000			
C				1400			2400
D				1400			770 (556)

INSTRUMENT APPROACH CHART

RJCN / NAKASHIBETSU

ILS Y or LOC Y RWY08

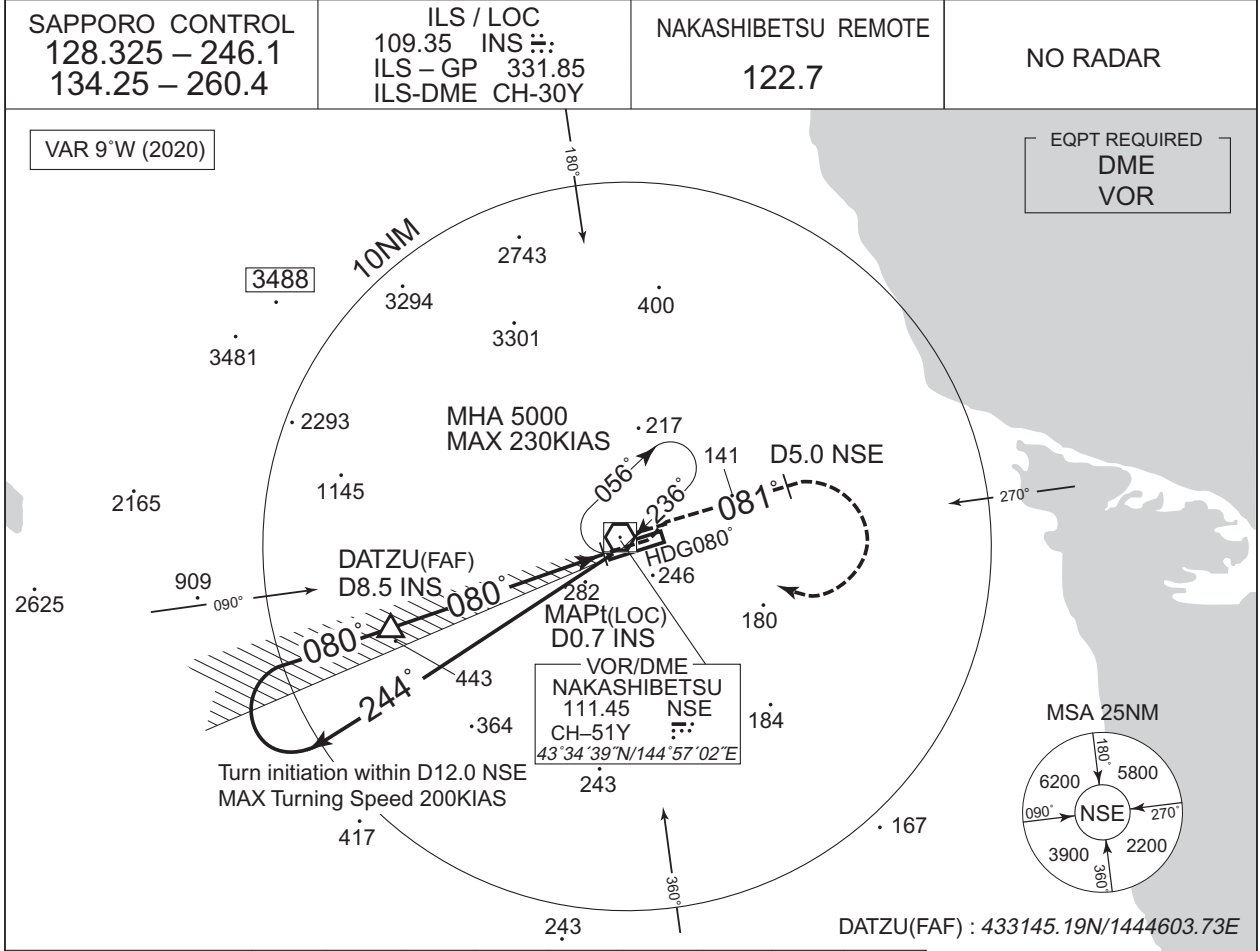

NM to INS	FAF	8	7	6	5	4	3	2	MAPt
ALT (3.0° APCH Path)	2934	2767	2449	2130	1812	1494	1175	856	–

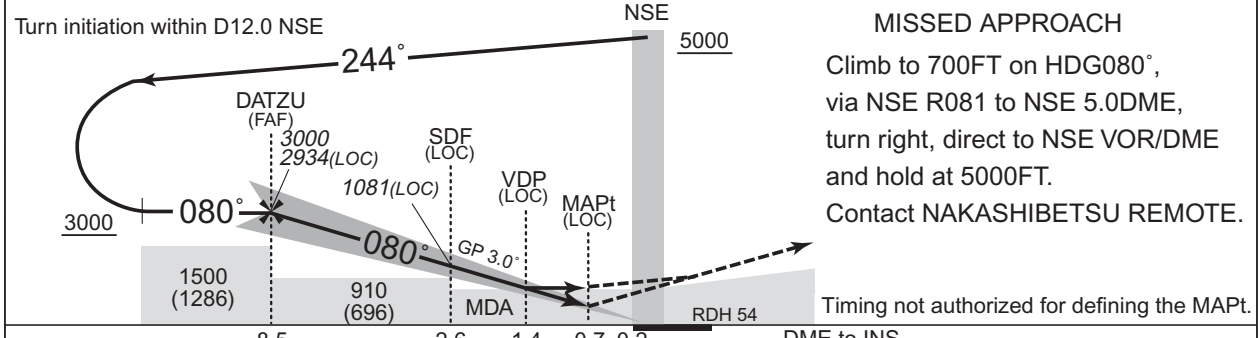

8.5	2.6	1.4	0.7	0.2	DME to INS
8.3	2.5	1.2	0.5	0	NM to THR

MINIMA		THR elev. 233		AD elev. 214		
CAT	CAT I		LOC		CIRCLING	
	DA(H)	RVR/CMV	MDA(H)	RVR/CMV	MDA(H) VIS	
A	433 (200)	550	640 (426)	900	1600	
B				1000		770 (556)
C				1400	690 (476)	
D						

CHANGE : VAR. Bearing on HOLD Pattern.

yinlei.orgは航空ファンのために空港チャートを整理しました。

INSTRUMENT APPROACH CHART

RJCN / NAKASHIBETSU

VOR RWY08

SAPPORO CONTROL 128.325 – 246.1 134.25 – 260.4	NAKASHIBETSU VOR/DME 111.45 NSE CH-51Y 43°34'39"N/144°57'02"E	NAKASHIBETSU REMOTE 122.7	NO RADAR
--	--	------------------------------	----------

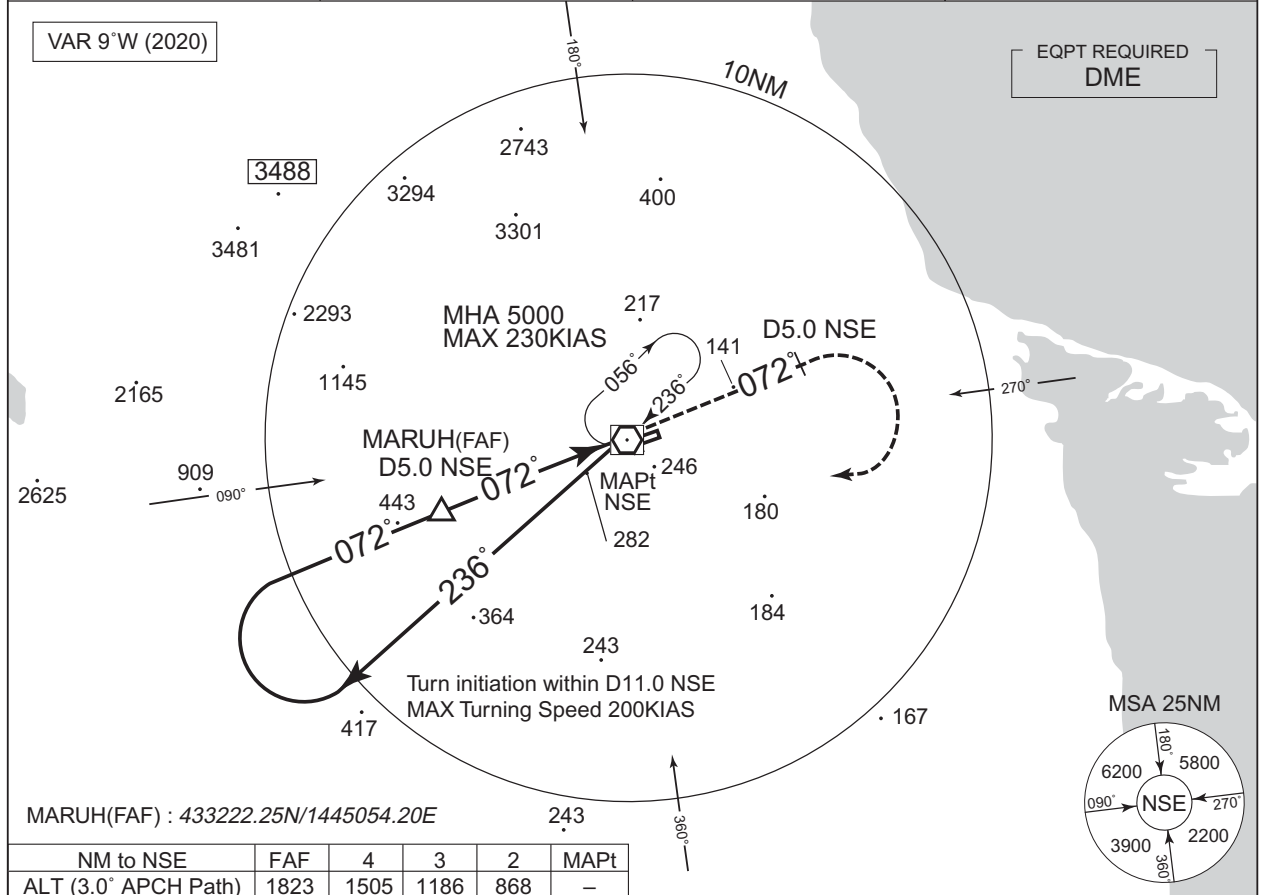

CHANGE : VAR. Radial FM NSE. Bearing on HOLD Pattern.

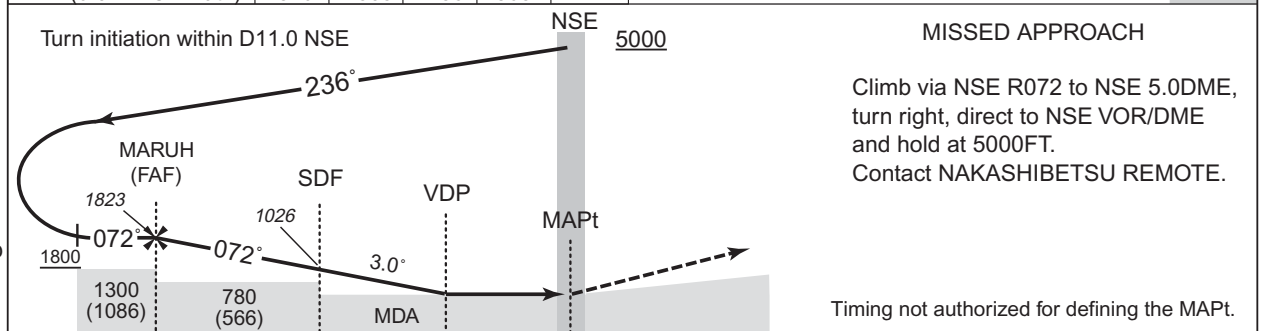

5.0	2.5	1.4	0.2	DME to NSE
4.8	2.3	1.2	0	NM to THR

MINIMA		THR elev. 233	AD elev. 214	
CAT	MDA(H)		CIRCLING	
	RVR/CMV	MDA(H)	VIS	
A	640 (426)	900	690 (476)	1600
B		1000		
C	650 (436)	1400	770 (556)	2400
D				3200

INSTRUMENT APPROACH CHART

RJCN / NAKASHIBETSU

VOR RWY26

SAPPORO CONTROL 128.325 – 246.1 134.25 – 260.4	NAKASHIBETSU VOR/DME 111.45 NSE CH-51Y 43°34'39"N/144°57'02"E	NAKASHIBETSU REMOTE 122.7	NO RADAR
--	--	------------------------------	----------

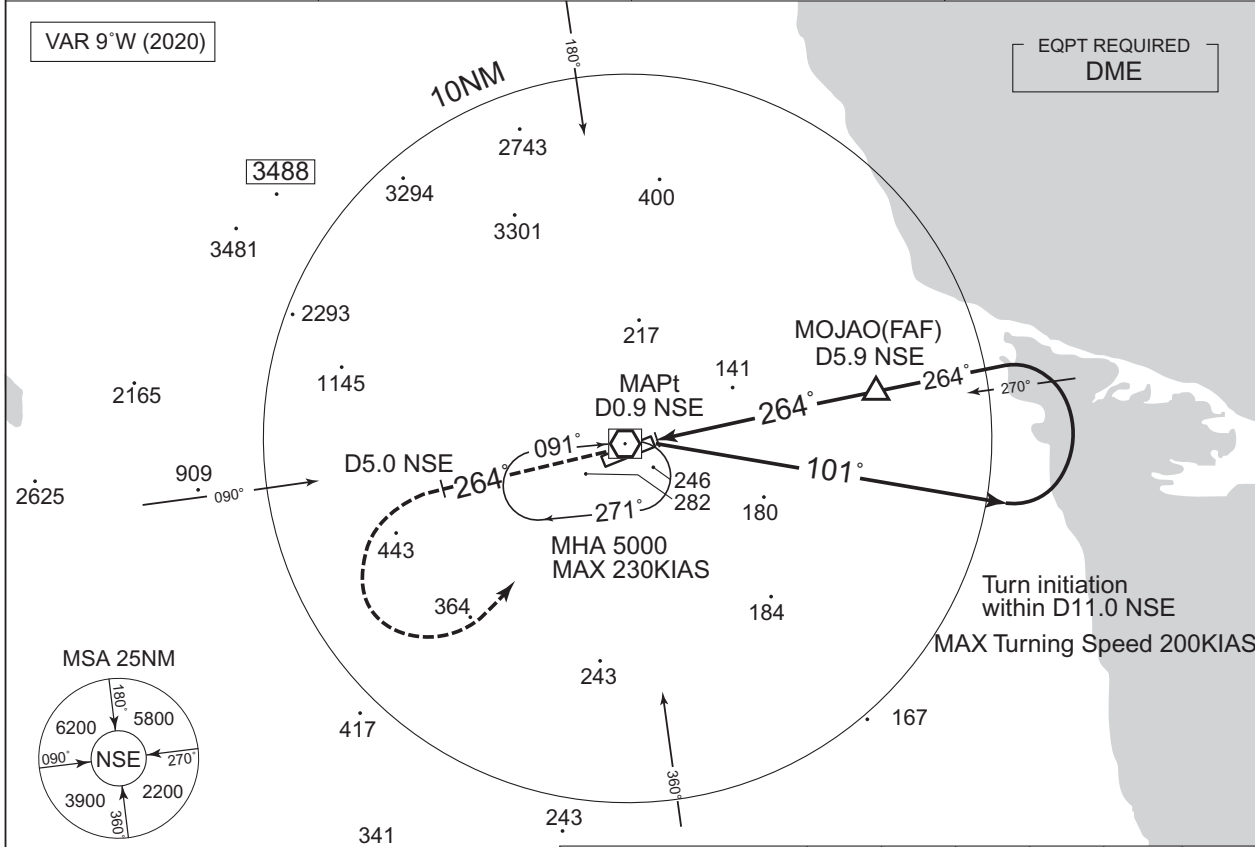

NM to NSE	MAPt	2	3	4	5	FAF
ALT (3.0° APCH Path)	-	602	920	1239	1557	1853

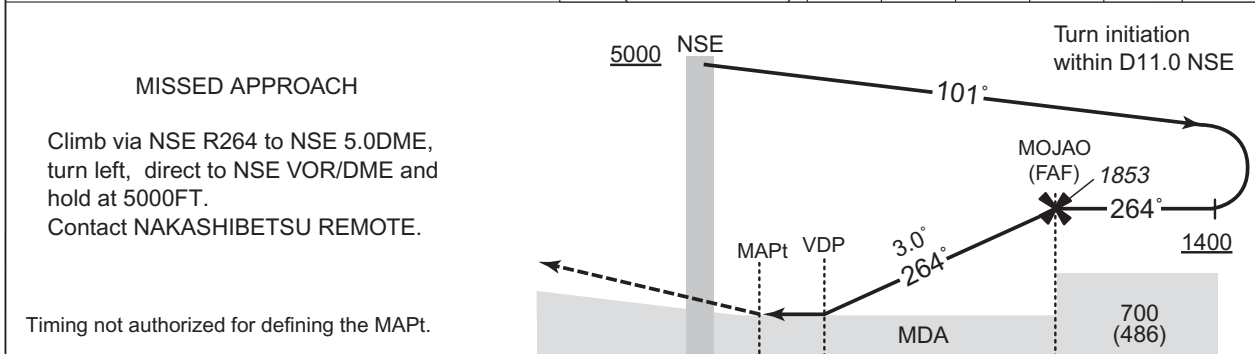

DME to NSE	0.9	2.0	5.9
NM to THR	0	1.0	5.0

MINIMA		THR elev. 212	AD elev. 214
CAT	CIRCLING		
	MDA(H)	CMV	MDA(H) VIS
A	580 (366)	1200	690 (476) 1600
B		1300	
C		1400	2400
D		1600	770 (556) 3200

CHANGE : VAR.

RJCN / NAKASHIBETSU

Visual REP

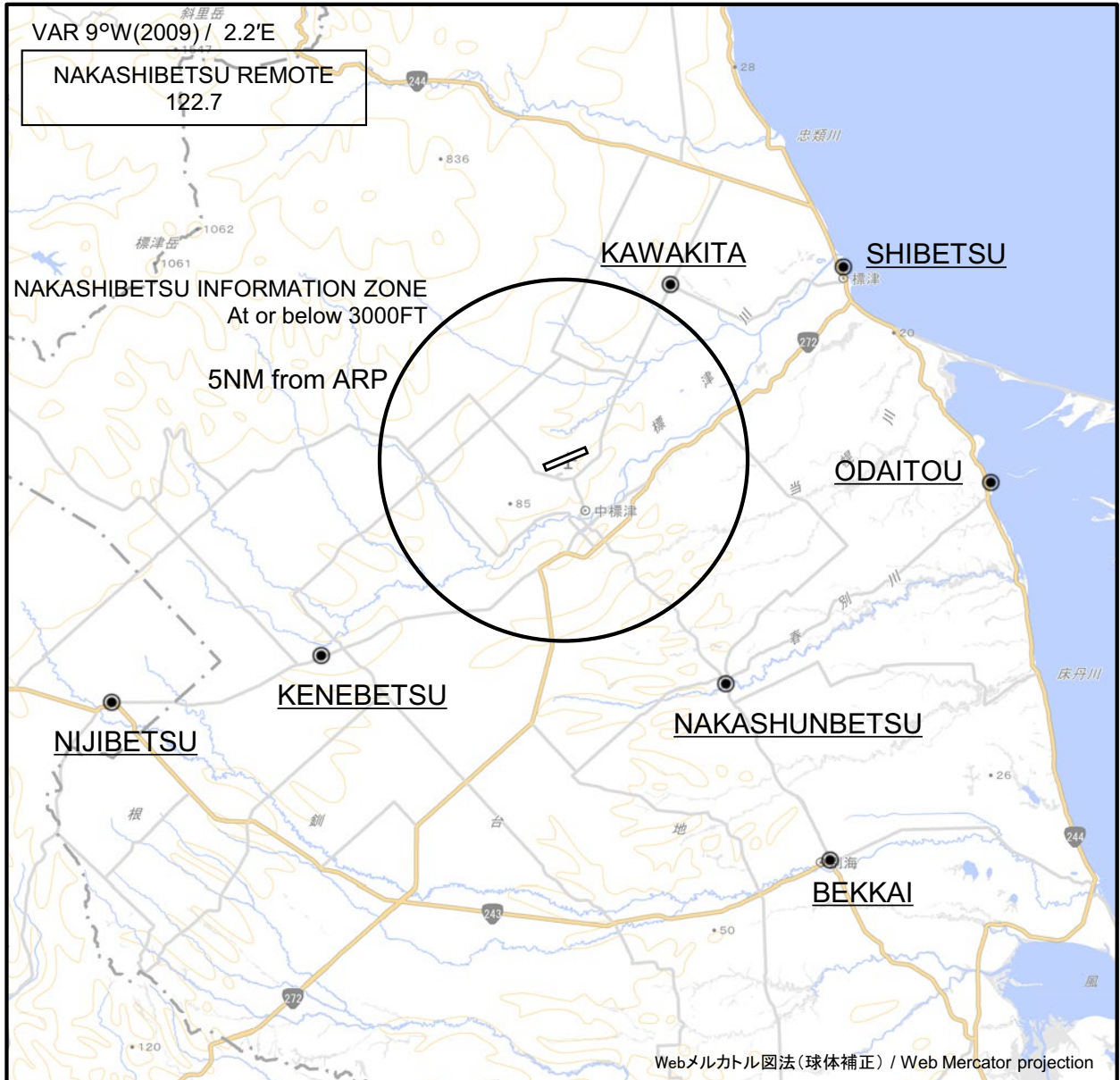

※図中に標高を示す数字がある場合、単位はメートル(m)である。The unit of measurement used to express elevation is meter(m).

CHANGE : Map updated. BRG/DIST from ARP.

Call sign	BRG / DIST from ARP	Remarks
標津 Shibetsu	055°T / 9.1NM	標津港 Harbor
川北 Kawakita	030°T / 5.6NM	市街地 Town
尾岱沼 Odaitou	093°T / 11.5NM	尾岱沼港 Harbor
計根別 Kenebetsu	231°T / 8.5NM	市街地 Town
中春別 Nakashunbetsu	145°T / 7.5NM	市街地 Town
虹別 Nijibetsu	242°T / 13.9NM	市街地 Town
別海 Bekkai	147°T / 13.1NM	市街地 Town

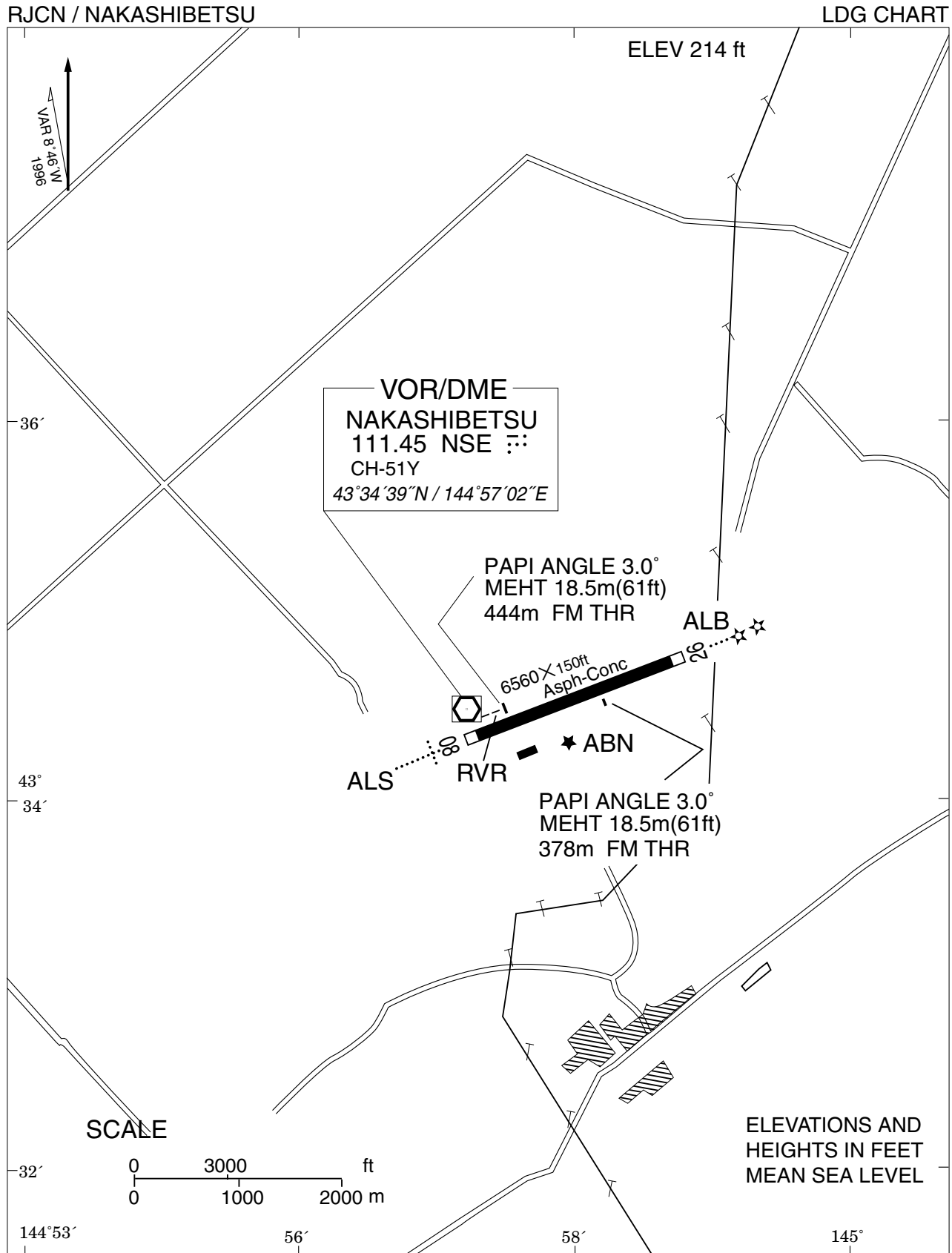

RJCN / NAKASHIBETSU

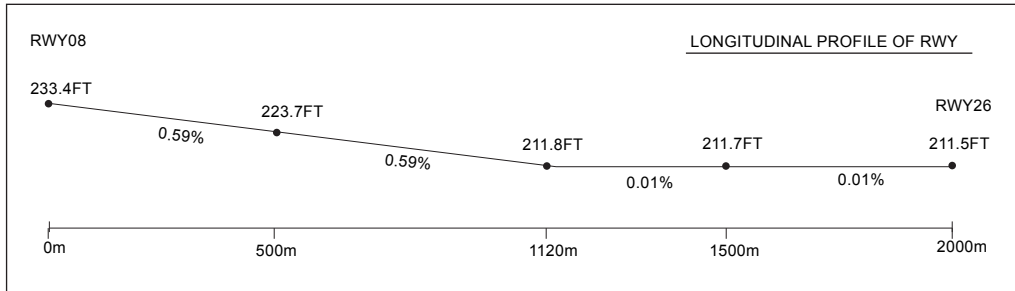

NAKASHIBETSU AP

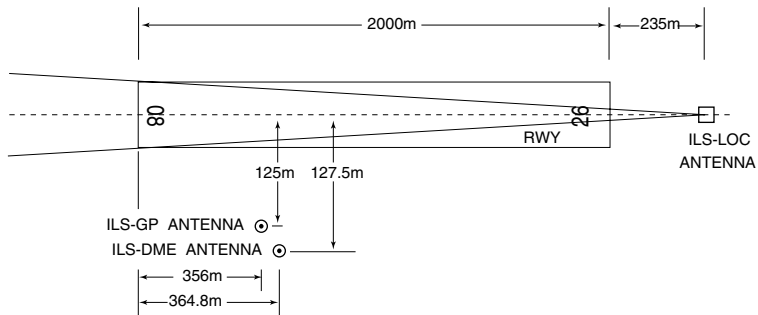

- REMARKS :
- | | |
|-------------------------|--------------|
| 1. LOC beam BRG (MAG) | 080° |
| 2. GP Angle | 3.0° |
| 3. HGT of ILS REF datum | 16.5m(54 ft) |
| 4. ELEV of ILS-DME | 73.6m(242ft) |

B-767型機用の滑走路180° 転回実施要項

1. 滑走路中心線からターニングパッド中心線標識に従って進行する。
2. 転回灯1が一直線に見えるように進行し、転回灯2が一直線に見えた時転回を開始する。

Procedure of 180° turn on RWY for B-767 aircraft

1. Proceed along the RWY Center Line Marking to the starting point of the RWY Turn Pad Center Line Marking ; then
2. Proceed along the RWY Turn Pad Center Line Marking to see the Turning Point Indicator Light 1 on a straight line, then commence turn at the spot where you (pilot) can see the Turning Point Indicator Light 2 on a straight line at an angle of 9 o'clock.

