

AD 2 AERODROMES

RJCH AD 2.1 AERODROME LOCATION INDICATOR AND NAME

RJCH - HAKODATE

RJCH AD 2.2 AERODROME GEOGRAPHICAL AND ADMINISTRATIVE DATA

1	ARP coordinates and site at AD	414612N/1404919E
2	Direction and distance from (city)	7.6KM (4.1NM), BRG 095° from Hakodate JR Station
3	Elevation/ Reference temperature	111.9ft / 25°C (2004-2008)
4	Geoid undulation at AD ELEV PSN	112.5FT
5	MAG VAR/ Annual change	9°W (2009) / 1.2'E
6	AD Administration, address, telephone, telefax, telex, AFS, e-mail and/or Web-site addresses	Hokkaido Airports Co.,Ltd. Hakodate Airport Office 511, Takamatsu-cho, Hakodate, Hokkaido TEL: 0138-57-1620 FAX:0138-57-1621
7	Types of traffic permitted (IFR/VFR)	IFR/VFR
8	Remarks	Hakodate Airport Office(Civil Aviation Bureau) 511, Takamatsu-cho, Hakodate, Hokkaido TEL:0138-57-1737, FAX:0138-59-4745 e-mail and web-site:Nil

RJCH AD 2.3 OPERATIONAL HOURS

1	AD Administration	2230 - 1130
2	Customs and immigration	INTL SKED FLT hours only
3	Health and sanitation	Quarantine(human): 2330-0815 Quarantine(animal): 2330-0800 Quarantine(plant): INTL SKED FLT hours only
4	AIS Briefing Office	Nil
5	ATS Reporting Office(ARO)	Nil
6	MET Briefing Office	H24 (NEW CHITOSE)
7	ATS	2230 - 1130
8	Fuelling	2230 - 1130
9	Handling	2230 - 1130
10	Security	2230 - 1130
11	De-icing	Nil
12	Remarks	Nil

RJCH AD 2.4 HANDLING SERVICES AND FACILITIES

1	Cargo-handling facilities	All the modern institutions that deal with the weight thing to a Boeing747 type freighter
2	Fuel/ oil types	Fuel grades: JET A-1 Oil grades: W80, MJO-2
3	Fuelling facilities/ capacity	Fuel Truck Refuelling
4	De-icing facilities	Nil
5	Hangar space for visiting aircraft	Nil
6	Repair facilities for visiting aircraft	Nil
7	Remarks	Nil

RJCH AD 2.5 PASSENGER FACILITIES

1	Hotels	Hotels in Hakodate city
2	Restaurants	Available , Not continuous
3	Transportation	Busses and Taxis
4	Medical facilities	Hospitals in Hakodate city
5	Bank and Post Office	Bank in Hakodate city, Post office in Hakodate city
6	Tourist Office	Tourist office in Hakodate city
7	Remarks	Nil

RJCH AD 2.6 RESCUE AND FIRE FIGHTING SERVICES

1	AD category for fire fighting	CAT 9
2	Rescue equipment	Fire engines
3	Capability for removal of disabled aircraft	Nil
4	Remarks	Nil

RJCH AD 2.7 SEASONAL AVAILABILITY-CLEARING

1	Types of clearing equipment	Snow removed equipment: a) rotatry x 3 b) snow plows x 4 c) snow sweeper x 4 d) urea sprinkler equipment x 1
2	Clearance priorities	1.RWY, 2.TWY, 3.APRON
3	Remarks	Seasonal availability: All seasons.

RJCH AD 2.8 APRONS, TAXIWAYS AND CHECK LOCATIONS DATA

1	Apron surface and strength	Surface: Concrete Strength: PCN 74/F/B/X/T
2	Taxiway width, surface and strength	Width: P1 - P6 : 23m T1, T7 : 28.5m T2 - T6 : 34m Surface: All TWY(except P2 and P3 behind SPOT1-10) : Asphalt Concrete TWY P2 and P3 behind SPOT1-10 : Concrete Strength: All TWY(except P2 and P3 behind SPOT1-10) : PCN 98/F/C/X/T TWY P2 and P3 behind SPOT1-10 : PCN 74/F/B/X/T
3	ACL and elevation	Not available
4	VOR checkpoints	Not available
5	INS checkpoints	Spot NR 1 414631.62N, 1404848.33E 2W 414631.87N, 1404849.46E 2 414631.17N, 1404850.18E 3 414631.21N, 1404852.59E 4 414630.51N, 1404855.48E 5 414629.73N, 1404858.32E 6 414628.84N, 1404900.90E 7 414628.03N, 1404903.16E 8 414627.48N, 1404905.43E 9 414626.98N, 1404907.49E 10 414626.45N, 1404909.65E
6	Remarks	Nil

RJCH AD 2.9 SURFACE MOVEMENT GUIDANCE AND CONTROL SYSTEM AND MARKINGS

1	Use of aircraft stand ID signs, TWY guide lines and Visual docking/ parking guidance system of aircraft stands	ACFT stand ID signs:NR.3, NR.4 and NR.5 ACFT stand taxi lane:Nil Visual docking guidance system :Nil
2	RWY and TWY markings and LGT	RWY: RWY12/30 (Marking) RWY designation, RWY CL, RWY THR, Aiming point, TDZ, RWY side stripe (LGT): RCLL, REDL, RTHL, RENL, RTZL(RWY12), WBAR(RWY12), RWY DIST marker LGT TWY: P1-P6 (Marking) TWY CL, TWY side stripe (LGT) TWY edge LGT, TWY CL LGT TWY: T1-T7 (Marking) TWY CL, RWY HLDG PSN, TWY side stripe (LGT) TWY edge LGT, TWY CL LGT, RWY guard LGT, Taxiing guidance sign
3	Stop bars	Nil
4	Remarks	(Marking) Overrun area (LGT) Apron flood LGT

RJCH AD 2.10 AERODROME OBSTACLES

SEE ATTACHED CHARTS

In approach/TKOF areas

RWY/Area affected	Obstacle type	Coordinates	Elevation	Markings/ LGT	Remarks
RWY30	Light Facility	414557.2N/1405024.8E	152FT		
RWY30	Light Facility	414556.5N/1405027.3E	152FT		
RWY30	Antenna	414556.0N/1405028.2E	160FT		
RWY30	LOC	414555.3N/1405032.1E	165FT		
RWY30	Building	414556.7N/1405033.0E	164FT		
RWY30	Fence	414555.5N/1405033.5E	161FT		
RWY30	Tree	414551.5N/1405033.2E	171FT		
RWY30	Tree	414550.4N/1405035.0E	169FT		
RWY30	Light Facility	414554.0N/1405037.1E	162FT		
RWY30	Light Facility	414553.4N/1405039.6E	165FT		
RWY30	Light Facility	414552.8N/1405042.1E	168FT		
RWY30	Light Facility	414552.1N/1405044.5E	171FT		
RWY30	Post	414551.9N/1405045.7E	176FT		
RWY30	Light Facility	414551.6N/1405046.9E	174FT		
RWY30	Light Facility	414551.0N/1405049.3E	177FT		
RWY30	Tree	414549.6N/1405049.2E	181FT		
RWY30	Light Facility	414550.4N/1405052.0E	180FT		
RWY30	Light Facility	414549.8N/1405054.4E	183FT		
RWY30	Light Facility	414549.2N/1405056.9E	186FT		
RWY30	Light Facility	414548.6N/1405059.4E	189FT		
RWY12	Light Facility	414628.2N/1404816.4E	93FT		
RWY12	Fence	414628.7N/1404814.0E	95FT		
RWY12	Post	414633.5N/1404809.4E	104FT		
RWY12	Post	414633.1N/1404807.6E	101FT		
RWY12	Post	414632.3N/1404804.9E	105FT		
RWY12	Post	414634.8N/1404805.3E	106FT		
RWY12	Post	414633.5N/1404804.3E	106FT		
RWY12	Tree	414630.0N/1404801.3E	102FT		
RWY12	Rod	414640.3N/1404736.1E	132FT		
RWY12	Rod	414645.2N/1404734.8E	162FT		
RWY12	Rod	414646.0N/1404733.7E	164FT		
RWY12	Rod	414646.8N/1404732.0E	164FT		
RWY12	Rod	414643.6N/1404658.5E	171FT		
RWY12	Post	414633.8N/1404811.5E	100FT		
RWY12	Building	414635.5N/1404807.7E	100FT		
RWY12	Post	414635.9N/1404806.7E	111FT		
RWY12	Post	414635.7N/1404805.2E	105FT		
RWY12	Antenna	414637.3N/1404805.9E	103FT		
RWY12	Post	414636.5N/1404805.5E	110FT		
RWY12	Chimney	414637.3N/1404804.9E	111FT		
RWY12	Lamppost	414626.9N/1404759.8E	97FT		
RWY12	Building	414628.1N/1404750.0E	125FT		

RWY/Area affected	Obstacle type	Coordinates	Elevation	Markings/ LGT	Remarks
RWY12	Rod	414633.0N/1404720.2E	170FT		
	Spire	414805.6N/1405049.0E	464FT		
	Spire	414811.5N/1404802.8E	293FT		
	Spire	414812.6N/1405042.4E	540FT		
	Rod	414713.0N/1405202.5E	338FT		
	Spire	414817.5N/1404804.3E	292FT		
	Spire	414819.4N/1405035.8E	562FT		
	Antenna	414834.3N/1404848.9E	424FT		
	Spire	414826.4N/1405033.8E	559FT		
	Spire	414822.2N/1404741.2E	344FT		
	chimney	414824.9N/1404743.9E	327FT		
	Spire	414830.4N/1404756.8E	362FT		
	Building	414830.1N/1404752.9E	340FT		
	Spire	414826.1N/1404740.3E	369FT		
	Spire	414842.2N/1405026.8E	541FT		
	Antenna	414849.6N/1404847.6E	438FT		
	Spire	414843.6N/1404747.0E	416FT		
	Spire	414858.3N/1405002.8E	595FT		
	Spire	414905.8N/1404952.3E	618FT		
	Spire	414851.8N/1404739.5E	453FT		
	Spire	414912.0N/1404943.6E	702FT		
	Spire	414915.6N/1404932.4E	570FT		
	Spire	414900.2N/1404736.9E	488FT		
	Spire	414917.8N/1404920.0E	530FT		
	Spire	414919.5N/1404906.0E	654FT		
	Spire	414921.4N/1404850.7E	629FT		
	Spire	414905.9N/1404735.2E	491FT		
RWY 12	Rod	414643.3N/1404704.1E	174FT		
	Building	414825.4N/1405040.2E	573FT		
	Antenna	414854.4N/1404843.5E	437FT		
	Post	414835.0N/1404917.1E	413FT		
	Tree	414839.8N/1404912.7E	446FT		
	Building	414847.3N/1404850.0E	407FT		Above the conical surface
	Building	414847.8N/1404833.6E	403FT		Above the conical surface
	Building	414854.4N/1404856.4E	427FT		Above the conical surface
	Building	414820.0N/1405000.0E	423FT	- / LIL	Above the conical surface
	Building	414830.7N/1405007.6E	398FT	- / -	Above the conical surface
	Spire	414820.2N/1404852.4E	414FT	Marking / LIL	Above the conical surface
	Spire	414829.1N/1404859.3E	406FT	Marking / -	Above the conical surface
	Spire	414830.4N/1404906.0E	394FT	- / -	Above the conical surface
	Spire	414833.4N/1404854.2E	388FT	Marking / -	Above the conical surface
	Spire	414841.1N/1404851.4E	391FT		Above the conical surface
	Spire	414830.9N/1404919.9E	387FT	Marking / LIL	Above the conical surface
	Spire	414822.3N/1405031.8E	480FT	- / -	Above the conical surface
Spire	414820.4N/1405036.0E	524FT	- / -	Above the conical surface	
Spire	414815.0N/1405041.3E	545FT	Marking / -	Above the conical surface	

RWY/Area affected	Obstacle type	Coordinates	Elevation	Markings/ LGT	Remarks
	Spire	414807.6N/1405048.9E	476FT	Marking / -	Above the conical surface
	Spire	414800.5N/1405055.3E	406FT	Marking / -	Above the conical surface
	Spire	414811.5N/1404803.2E	350FT	Marking / -	Above the conical surface
	Building	414831.3N/1405009.2E	398FT	- / -	Above the conical surface
	Spire	414826.3N/1404757.7E	363FT	Marking / -	Above the conical surface
	Spire	414818.6N/1404807.1E	378FT	Marking / LIL	Above the conical surface

In circling area and at AD

Obstacle type	Coordinates	Elevation	Markings/ LGT	Remarks
Building	414632.7N/1404818.4E	102FT		
Post	414634.3N/1404815.8E	114FT		
Post	414637.4N/1404807.7E	106FT		
Building	414602.1N/1405028.7E	161FT		
Lamppost	414637.9N/1404808.9E	117FT		
Post	414635.4N/1404816.0E	126FT		
Post	414635.0N/1404819.8E	123FT		
Post	414636.1N/1404816.0E	126FT		
Post	414634.4N/1404822.6E	117FT		
Fence	414604.3N/1405030.7E	182FT		
Equipment	414616.2N/1404941.6E	168FT		
Post	414637.4N/1404816.0E	128FT		
ITV	414623.9N/1404914.3E	139FT		
ABN	414633.3N/1404844.6E	185FT		
Light Pole	414628.3N/1404907.9E	192FT		
Light Pole	414630.8N/1404857.0E	191FT		
Light Pole	414629.8N/1404902.2E	192FT		
Light Pole	414631.7N/1404854.6E	190FT		
Light Pole	414627.4N/1404913.1E	192FT		
Light Pole	414627.9N/1404911.0E	192FT		
Fence	414612.8N/1405014.8E	241FT		
Fence	414615.3N/1405004.4E	246FT		
Rod	414630.3N/1404903.8E	219FT		
Tree	414618.6N/1404830.4E	116FT		
Tree	414616.0N/1404840.9E	139FT		

Obstacle type	Coordinates	Elevation	Markings/ LGT	Remarks
Tree	414603.3N/1404932.7E	142FT		
Building	414629.9N/1404711.2E	182FT		
Antenna	414603.2N/1404929.2E	147FT		
Rod	414621.0N/1404757.2E	166FT		
Signboard	414618.8N/1404810.9E	136FT		
Antenna	414559.6N/1404919.4E	166FT		
Equipment	414631.8N/1404909.0E	227FT		
Antenna	414549.6N/1404937.0E	226FT		
Equipment	414626.5N/1404957.2E	292FT		
Post	414633.2N/1404959.4E	260FT		
Signboard	414632.8N/1405000.6E	261FT		
Building	414633.9N/1405001.9E	270FT		
Building	414619.2N/1405010.5E	288FT		
Post	414623.4N/1405014.3E	298FT		
Antenna	414539.0N/1405005.7E	206FT		
Antenna	414816.0N/1404947.4E	407FT		
Rod	414815.4N/1404958.4E	438FT		
Spire	414754.3N/1405100.0E	370FT		
Antenna	414819.1N/1404905.8E	401FT		
chimney	414818.4N/1405001.7E	458FT		
Antenna	414820.0N/1404905.0E	401FT		Above the horizontal surface
Post	414622.7N/1405024.0E	273FT		
Antenna	414622.1N/1405025.0E	314FT		
Post	414620.7N/1405026.7E	262FT		
Post	414629.5N/1405029.6E	292FT		
Tree	414647.6N/1405024.0E	302FT		
Building	414716.9N/1404921.4E	280FT		
Spire	414632.5N/1405043.2E	298FT		
Spire	414644.0N/1405039.6E	317FT		
Spire	414703.0N/1405031.9E	326FT		
Post	414653.9N/1405043.5E	322FT		
Building	414629.4N/1405102.3E	255FT		
Tree	414729.4N/1404959.6E	334FT		
Spire	414733.3N/1405000.6E	321FT		
Antenna	414737.0N/1404959.0E	377FT		
Spire	414740.1N/1404946.4E	378FT		
Spire	414614.6N/1405121.2E	257FT		
Spire	414742.9N/1404935.0E	400FT		
Spire	414606.3N/1405123.6E	253FT		
Building	414737.9N/1405011.4E	313FT		
Spire	414743.6N/1404952.0E	377FT		
Rod	414747.6N/1404928.6E	350FT		
Lamppost	414731.4N/1405037.0E	315FT		
Building	414751.4N/1404952.6E	348FT		
Spire	414754.7N/1404843.8E	351FT		
Spire	414722.9N/1405108.6E	318FT		

Obstacle type	Coordinates	Elevation	Markings/ LGT	Remarks
Antenna	414802.1N/1404939.9E	411FT		
Spire	414743.6N/1405107.5E	301FT		
Post	414619.7N/1405050.8E	269FT		
Rod	414742.2N/1404927.7E	328FT		
Post	414627.4N/1405044.8E	267FT		
Spire	414700.7N/1405033.4E	327FT		
Spire	414731.5N/1405108.2E	323FT		
Rod	414803.5N/1404947.0E	430FT		
Antenna	414740.0N/1404942.0E	383FT		Above the horizontal surface
Building	414804.3N/1404943.2E	381FT	- / -	Above the horizontal surface
Spire	414811.3N/1404845.5E	341FT	Marking / -	Above the horizontal surface
Spire	414752.8N/1405102.4E	304FT	- / -	Above the horizontal surface
Spire	414743.8N/1405108.2E	298FT	Marking / -	Above the horizontal surface
Spire	414730.6N/1405109.1E	309FT	- / -	Above the horizontal surface
Spire	414807.0N/1404806.1E	309FT	- / -	Above the horizontal surface
Spire	414803.6N/1404816.9E	313FT	Marking / -	Above the horizontal surface
Spire	414801.7N/1404823.0E	314FT	Marking / LIL	Above the horizontal surface
Antenna	414748.6N/1404929.7E	341FT	- / -	Above the horizontal surface
Antenna	414806.3N/1404945.3E	407FT	- / -	Above the horizontal surface
Building	414804.1N/1404943.8E	372FT	- / -	Above the horizontal surface
Spire	414826.6N/1405028.7E	549FT	- / -	Above the conical surface
Spire	414833.7N/1404931.0E	386FT	Marking / -	Above the conical surface
Spire	414837.1N/1404940.3E	340FT	Marking / LIL	Above the conical surface
Antenna	414851.9N/1404847.9E	460FT	Marking / -	Above the conical surface
Antenna	414827.7N/1405012.4E	406FT	- / -	Above the conical surface
Antenna	414748.1N/1404930.3E	311FT	- / -	Above the horizontal surface
Building	414834.4N/1405013.5E	418FT	- / -	Above the conical surface
Building	414828.7N/1405010.1E	408FT	- / -	Above the conical surface
Antenna	414822.4N/1404742.7E	330FT	- / -	Above the conical surface
Antenna	414817.2N/1404950.9E	392FT	- / -	Above the horizontal surface
Antenna	414821.6N/1404743.9E	349FT	- / -	Above the conical surface
Antenna	414821.5N/1404744.0E	349FT	- / -	Above the conical surface
Antenna	414816.0N/1404948.0E	400FT	- / -	Above the horizontal surface
Antenna	414904.0N/1404847.0E	479FT	- / -	Above the conical surface
Building	414902.0N/1404854.0E	465FT	- / -	Above the conical surface
Solar power plant	414835.3N/1404833.6E	375FT	- / -	Above the conical surface
Rod	414818N1404807E	303FT	- / -	Above the conical surface
Rod	414818N1404808E	306FT	- / -	Above the conical surface
Rod	414819N1404809E	308FT	- / -	Above the conical surface
Rod	414819N1404810E	314FT	- / -	Above the conical surface

RJCH AD 2.11 METEOROLOGICAL INFORMATION PROVIDED

1	Associated MET Office	NEW CHITOSE
2	Hours of service MET Office outside hours	H24 (NEW CHITOSE)
3	Office responsible for TAF preparation Periods of validity	NEW CHITOSE 30 Hours
4	Trend forecast Interval of issuance	Nil
5	Briefing/consultation provided	Briefing is available upon inquiry at NEW CHITOSE
6	Flight documentation Language(s) used	C En
7	Charts and other information available for briefing or consultation	S ₆ , U ₈₅ , U ₇ , U ₅ U ₃ , U ₂₅ , U ₂ /Tr, P _S , P ₅ , P ₃ , P ₂₅ , P _{SWE} , P _{SWF} , P _{SWG} , P _{SWI} , P _{SWM} , P _{SW(domestic)} , E, C, W _E , W _F , W _G , W _I , W, N
8	Supplementary equipment available for providing information	Nil
9	ATS units provided with information	TWR, APP, ATIS
10	Additional information(limitation of service, etc.)	Nil

RJCH AD 2.12 RUNWAY PHYSICAL CHARACTERISTICS

Designations RWY NR	TRUE BRG	Dimensions of RWY(M)	Strength(PCN) and surface of RWY	THR coordinates THR geoid undulation	THR elevation and highest elevation of TDZ of precision APP RWY
1	2	3	4	5	6
12	107.98°	3000×45	PCN 98/F/C/X/T Asphalt Concrete	414627.62N 1404817.61E 112.6FT	THR ELEV 92.2ft TDZ ELEV 103ft
30	287.98°	3000×45	PCN 98/F/C/X/T Asphalt Concrete	414557.54N 1405021.00E 112.5FT	THR ELEV 151ft

Slope of RWY	Strip Dimensions(M)	RESA (Overrun) Dimensions(M)	Remarks
7	10	11	14
see attached figure	3120×300 3120×300	192 × (MNM:102 MAX:300)* 47 × (MNM:217 MAX:300)* *For detail, ask airport administrator	RWY grooving 3000X45m

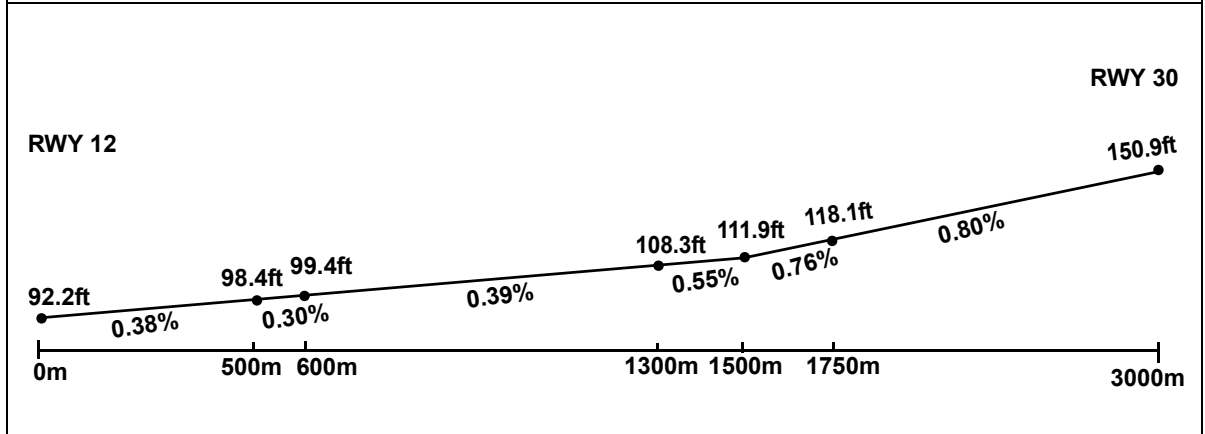

RJCH AD 2.13 DECLARED DISTANCES

RWY Designator	TORA (m)	TODA (m)	ASDA (m)	LDA (m)	Remarks
1	2	3	4	5	6
12	3000	3000	3000	3000	Nil
30	3000	3000	3000	3000	Nil

RJCH AD 2.14 APPROACH AND RUNWAY LIGHTING

RWY Designator	APCH LGT type LEN INTST	RTHL Color WBAR	PAPI (VASIS) Angle DIST FM THR MEHT	RTZL LEN	RCLL LEN Spacing Color INTST	REDL LEN Spacing Color INTST	RENL Color WBAR	STWL LEN Color
1	2	3	4	5	6	7	8	9
12	PALS (CAT I) 640m LIH	Green Green	PAPI 3.0°/Left 384m 65ft	900m	3000m 30m Coded Color (White/Red) LIH	3000m 60m Coded Color (White/Yellow) LIH	Red	Nil (*2)
30	SALS (*1) 420m LIH	Green -	PAPI 3.0°/Left 538m 74ft	-	3000m 30m Coded Color (White/Red) LIH	3000m 60m Coded Color (White/Yellow) LIH	Red	Nil (*2)
Remarks								
10								
SALS with RAI(LEN:480m) and APCH Guidance LGT(1341m and 1760m FM RWY THR) for RWY 30(*1) Overrun area edge LGT: LEN:60m Color:Red (*2)								

RJCH AD 2.15 OTHER LIGHTING, SECONDARY POWER SUPPLY

1	ABN/IBN location, characteristics and hours of operation	ABN: 414633N/1404843E, ALTN FLG(2)WG EV 4.3sec, HO
2	LDI location and LGT Anemometer location and LGT	LDI : Nil Anemometer: RWY12 400m WSW from ABN, LGTD RWY30 2350m ESE from ABN, LGTD
3	TWY edge and center line lighting	TWY edge and center line lights installed, see AD2.9
4	Secondary power supply/ switch-over time	Within 1sec : REDL, RENL, RTHL, WBAR, RCLL, Overrun area edge LGT Within 15sec: Other lights
5	Remarks	WDI LGT

RJCH AD 2.16 HELICOPTER LANDING AREA

Nil

RJCH AD 2.17 ATS AIRSPACE

Designation and lateral limits		Vertical limits (ft)	Airspace classification	ATS unit call sign Language	Remarks
1		2	3	4	6
HAKODATE CTR	Area within a radius of 5 nm of HAKODATE ARP (41°46'N140°49'E)	3000	D	HAKODATE TWR En	
HAKODATE ACA	SEE RJCH ATTACHED CHART		E	HAKODATE APP HAKODATE DEP HAKODATE RADAR En	

函館進入管制区
Hakodate Approach Control Area

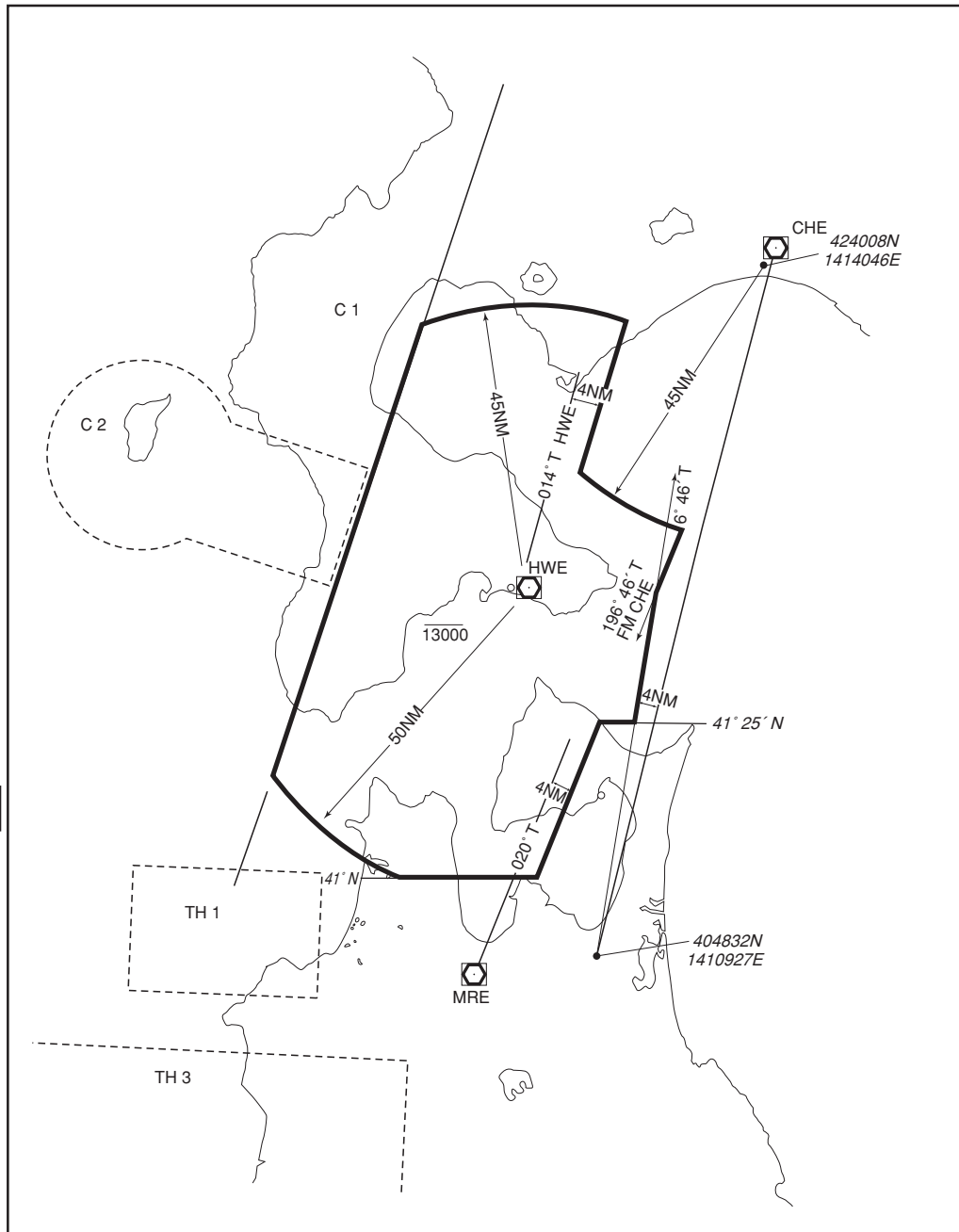

RJCH AD 2.18 ATS COMMUNICATION FACILITIES

Service designation	Call sign	Frequency	Hours of operation	Remarks
1	2	3	4	5
TWR	Hakodate Tower	118.35MHz(1) 126.2MHz(2) 121.5 MHz(E) 243.0 MHz(E)	2230 - 1130	(1)Primary (2)Secondary
APP/ASR	Hakodate Approach/Radar	119.0 MHz 121.0 MHz 121.5MHz(E) 243.0MHz(E)	2230 - 1130	
DEP	Hakodate Departure	127.9 MHz 121.0 MHz 121.5MHz(E) 243.0MHz(E)	2230 - 1130	
ATIS	Hakodate Airport	126.6MHz	2230 - 1130	

RJCH AD 2.19 RADIO NAVIGATION AND LANDING AIDS

Type of aid (VOR declination)	ID	Frequency	Hours of operation	Position of transmitting antenna coordinates	Elevation of DME transmitting antenna	Remarks
1	2	3	4	5	6	7
VOR (9°W/2014)	HWE	112.3MHz	H24	414626.51N/ 1404955.98E		VOR unusable: 020°-030° beyond 30nm BLW 6000ft. 030°-040° beyond 35nm BLW 5000ft. 070°-090° beyond 25nm BLW 5000ft. 090°-100° beyond 35nm BLW 5000ft. 100°-110° beyond 20nm BLW 4000ft. 200°-240° beyond 35nm BLW 5000ft. 340°-350° beyond 35nm BLW 6000ft. 350°-010° beyond 15nm BLW 6000ft.
DME	HWE	1157MHz (CH-70X)	H24	414626.51N/ 1404955.98E	300ft	DME unusable: 000°-020° beyond 25nm BLW 6000ft. 100°-110° beyond 35nm BLW 4000ft. 340°-360° beyond 30nm BLW 6000ft.
ILS-LOC 12	IHL	109.3MHz	2230 - 1130	414555.24N/ 1405030.81E		LOC:235m (771ft) away FM RWY 30 THR, BRG (MAG) 117°
ILS-GP 12	-	332.0MHz	2230 - 1130	414620.82N/ 1404827.84E		GP : 290m (951ft) FM inside RWY 12 THR, 126m (413ft) S of RCL. GP 3.0° HGT of ILS Ref datum 15.5m(51ft).
ILS-DME 12	IHL	991MHz (CH-30X)	2230 - 1130	414620.53N/ 1404828.07E	111ft	DME:297m(974ft) inside FM RWY 12 THR, 132m(433ft) S of RCL.
MSAS		1575.42MHz	H24			Transmitting antennas are satellite based.

ILS for RWY12

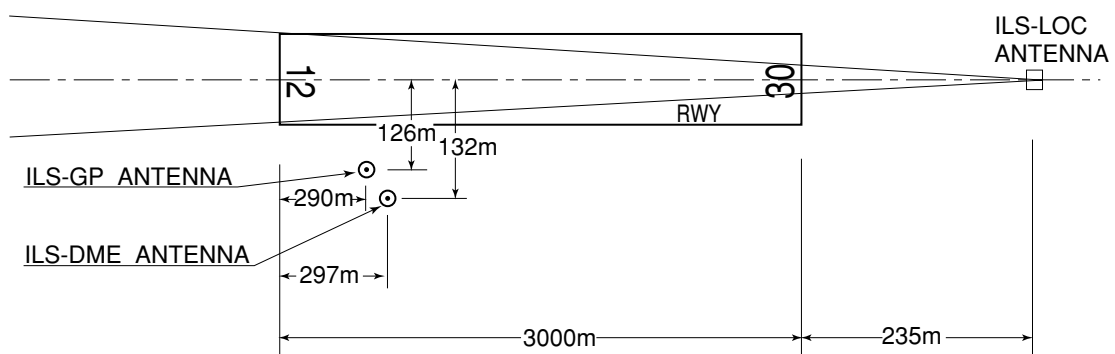

REMARKS : 1.ILS-LOC beam(BRG) 117°
2.ILS-GP Angle 3.0°
3.HGT of ILS REF datum 15.5m(51.0ft)
4.ELEV of ILS-DME 33.9m(111ft)

RJCH AD 2.20 LOCAL TRAFFIC REGULATIONS

1. Airport regulations

PPR

Prior permission is required for all transient aircraft due to parking congestion except scheduled and/or emergency flight.

Tel: Hokkaido Airports Co.,Ltd. Hakodate Airport Office 0138-57-1729

2. Taxiing to and from stands

Nil

3. Parking area for small aircraft(General aviation)

Nil

4. Parking area for helicopters

Nil

5. Apron - taxiing during winter conditions

Nil

6. Taxiing - limitations

Wing tip clearance at the TWY intersection (REF AD1.1.6.8)

Wing tip clearance at the TWY intersection between the aircraft holding at the stop marking on the TWY and the other aircraft taxiing behind it are as follows.

When B772 holding at the stop marking on TWY T2 or T6

Wing Span (WS) of aircraft taxiing on TWY P1-P2 or P5-P6	WS=<35.4m	35.4m<WS=<52.4m	WS >52.4m	Legend:
Wing tip clearance	*A	*B	*C	*A : wing tip clearance >= 15m *B : 6.5m =< wing tip clearance < 15m *C : wing tip clearance < 6.5m

7. School and training flights - technical test flights - use of runways

Nil

8. Helicopter traffic - limitation

Nil

9. Removal of disabled aircraft from runways

Nil

RJCH AD 2.21 NOISE ABATEMENT PROCEDURES

<p>1.Noise abatement Operating Procedures For all jet aircraft, in order to reduce aircraft noise in the vicinity of airport, the following procedures shall be applied unless compliance of the procedures adversely affects the safety of aircraft operations. In case that the aircraft is unable to take these procedures, pilots should execute alternative procedures which are considered to be practically equivalent. (1) For take-off from RWY30: Steepest Climb Procedure (2) For landing to RWY12: Delayed Flap Approach Procedure and Reduced Flap Setting Procedure (3) Reverse Thrust: Nil</p> <p>2. Preferential Runways Procedures: Nil</p> <p>3. Noise Preferential Routes: Nil</p> <p>1. 騒音軽減運航方式 すべてのジェット機に対して、空港周辺における航空機騒音軽減のため、運航の安全に支障のない範囲で、以下の方式が適用される。ただし、これらの方式によることができない航空機は実効的にこれらと同等と認められる代替方式を実施するものとする。</p> <p>(1) 離陸について（滑走路 30） 急上昇方式 (2) 着陸について（滑走路 12） デイレイド・フラップ進入方式及び低フラップ角着陸方式 (3) リバース・スラストについて なし</p> <p>2. 優先滑走路方式 なし</p> <p>3. 優先飛行経路 なし</p>
--

RJCH AD 2.22 FLIGHT PROCEDURES

1. TAKE OFF MINIMA

	RWY	ACFT CAT	REDL & RCLL		REDL or RCLL or RCL marking		NIL (DAYTIME ONLY)	
			RVR	VIS	RVR	VIS	RVR	VIS
Multi-Engine ACFT with TKOF ALTN AP Filed	12	A,B, C,D	400m	400m	400m	400m	-	500m
	30	A,B, C,D	-	400m	-	400m	-	500m
OTHER	12	A,B, C,D	AVBL LDG MINIMA					
	30	A,B, C,D						

2. Trajectorized Airport Traffic Data Processing System (TAPS)

Aircraft flying under control of Hakodate approach control in the approach control area will be instructed to reply with discrete code on Mode A/3 and Mode C

If an aircraft with non-discrete capability be instructed to reply with the discrete code, it shall report a controller accordingly.

函館アプローチの指示のもとに、当該進入管制区を飛行する航空機は、モード A/3 の二次レーダー個別コード及びモード C による応答を指示される。

二次レーダー個別コードを搭載していない航空機が当該コードによる応答を指示された場合は、管制官に対してその旨通報すること。

3. Lost communication procedures for arrival aircraft under radar navigational guidance

If radio communications with HAKODATE Approach/Radar are lost for 1 minute, squawk Mode A/3 Code 7600 and;

- (I)
1. Contact HAKODATE Tower.
 2. If unable, proceed in accordance with visual flight rules.
 3. If unable, proceed to HAKODATE VOR/DME at last assigned altitude or 5,000 feet whichever is higher, and execute instrument approach
- (II) Procedures other than above will be issued when situation required.

RJCH AD 2.23 ADDITIONAL INFORMATION

Nil

RJCH AD 2.24 CHARTS RELATED TO AN AERODROME

Aerodrome Chart

Aircraft Parking/Docking Chart

Aerodrome Obstacle Chart-ICAO type A (RWY12)

Aerodrome Obstacle Chart-ICAO type A (RWY30)

Aerodrome Obstacle Chart-ICAO type B

Standard Departure Chart-Instrument (HAKODATE SOUTH, HAKODATE REVERSAL, TAPPI, ESASI, TIKYU)

Standard Departure Chart-Instrument (TSUGARU-RNAV)

Standard Arrival Chart-Instrument (YAKEI-RNAV)

Standard Arrival Chart-Instrument (PATRA-RNAV)

Instrument Approach Chart (ILS Z or LOC Z RWY12)

Instrument Approach Chart (ILS Y or LOC Y RWY12)

Instrument Approach Chart (VOR RWY30)

Instrument Approach Chart (VOR RWY12)

Instrument Approach Chart (RNAV(GNSS) Z RWY30)

Instrument Approach Chart (RNAV(RNP) Y RWY30)

Instrument Approach Chart (RNAV(RNP) RWY12)

Other Chart (Visual REP)

Other Chart (LDG CHART)

Other Chart (MVA CHART)

AERODROME CHART

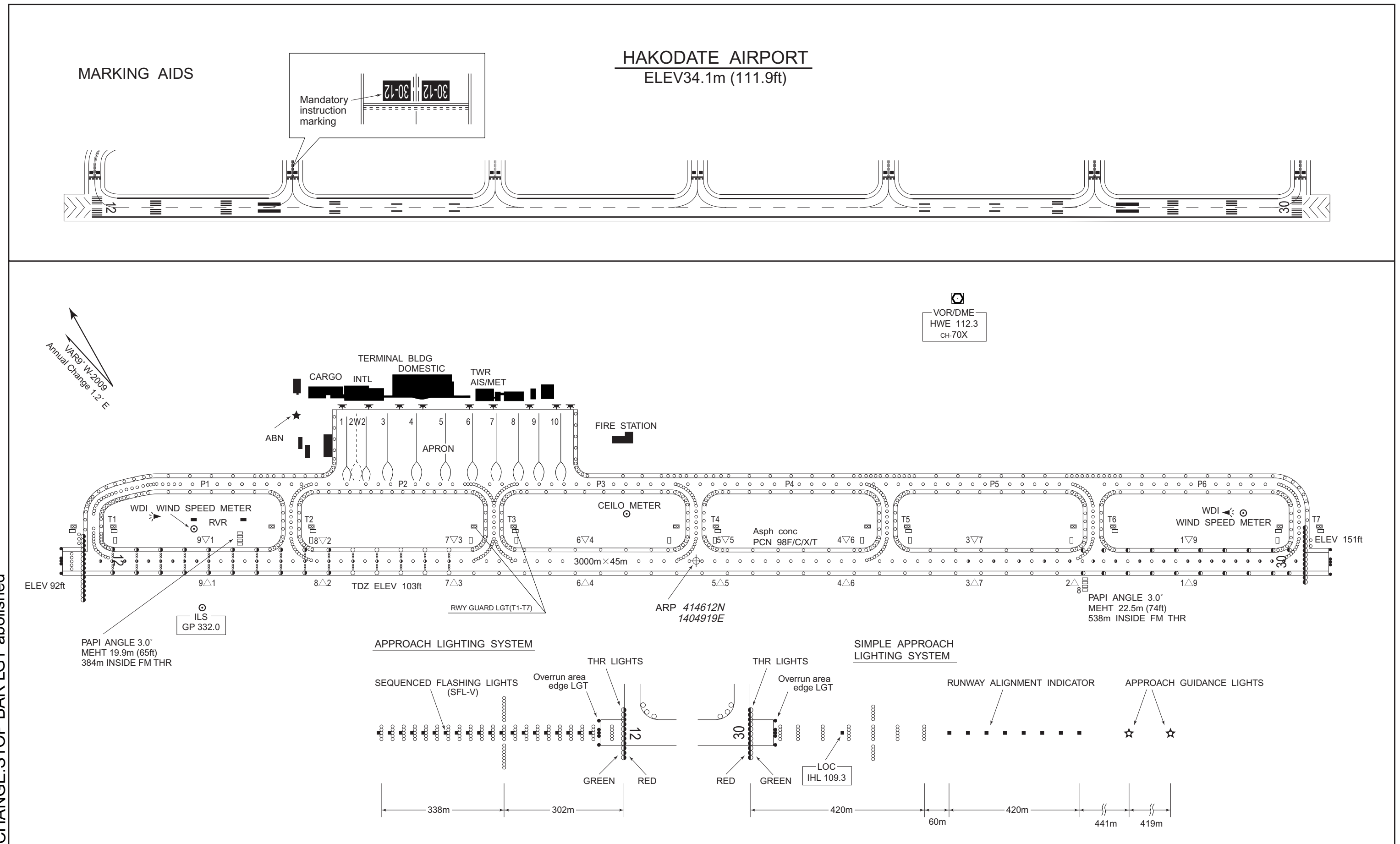

CHANGE: STOP BAR LGT abolished

INSTRUMENT APPROACH CHART

RJCH / HAKODATE

ILS Z or LOC Z RWY12

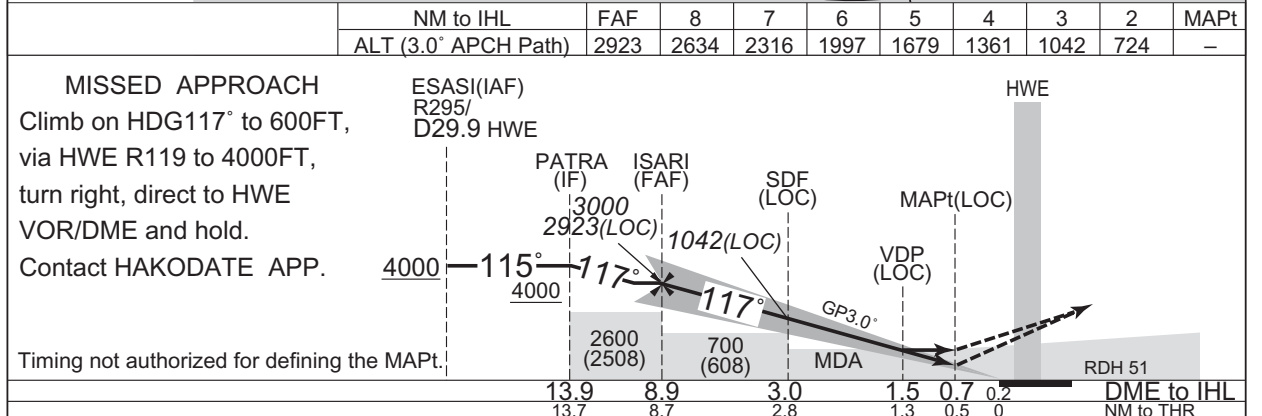
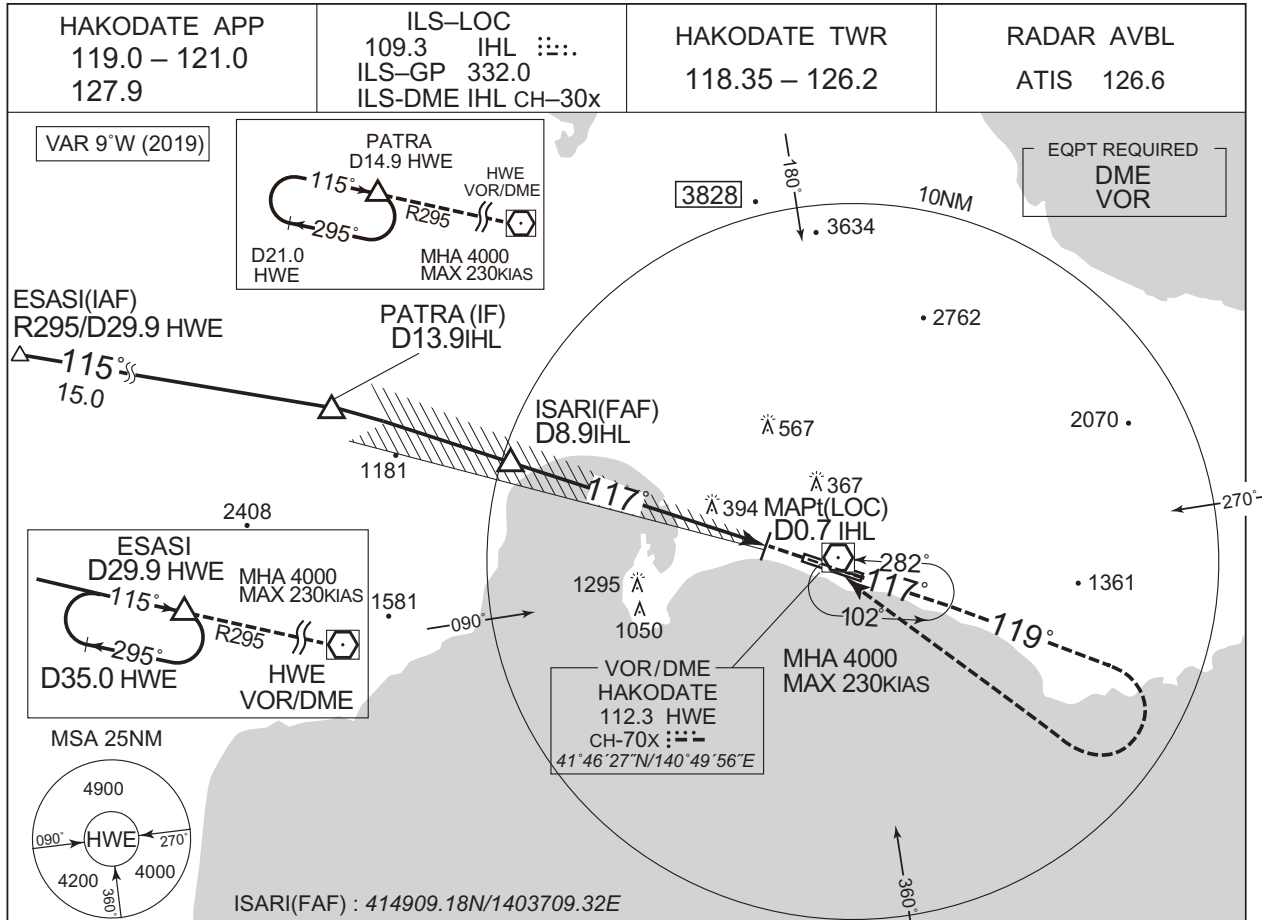

CHANGE : ALT restriction at PATRA.

MISSED APCH climb gradient MNM 5.0%

MINIMA		THR elev. 92		AD elev. 112		
CAT	CAT I		LOC		CIRCLING	
	DA(H)	RVR/CMV	MDA(H)	RVR/CMV	MDA(H)	VIS
A	292 (200)	700	540 (448)	1200	550 (438)	1600
B				1300	570 (458)	
C	299 (207)			1400	600 (488)	2400
D	309 (217)			1600	690 (578)	3200

Circling to SOUTH side of RWY only.
MINIMA with Missed APCH climb gradient of 2.5% are not established.

INSTRUMENT APPROACH CHART

RJCH / HAKODATE

ILS Y or LOC Y RWY12

HAKODATE APP 119.0 – 121.0 127.9	ILS-LOC 109.3 IHL :::: ILS-GP 332.0 ILS-DME IHL CH-30x	HAKODATE TWR 118.35 – 126.2	RADAR AVBL ATIS 126.6
--	---	--------------------------------	--------------------------

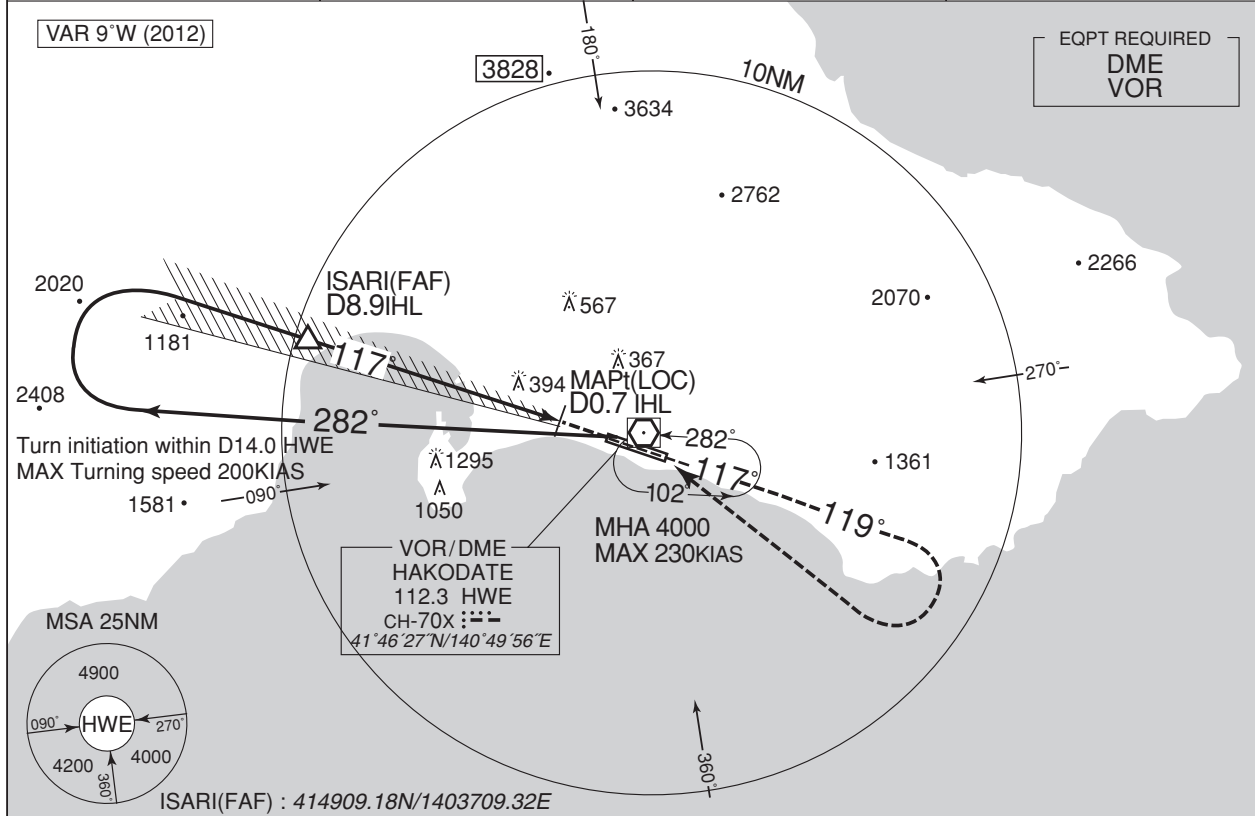

NM to IHL	FAF	8	7	6	5	4	3	2	MAPt
ALT (3.0° APCH Path)	2923	2634	2316	1997	1679	1361	1042	724	-

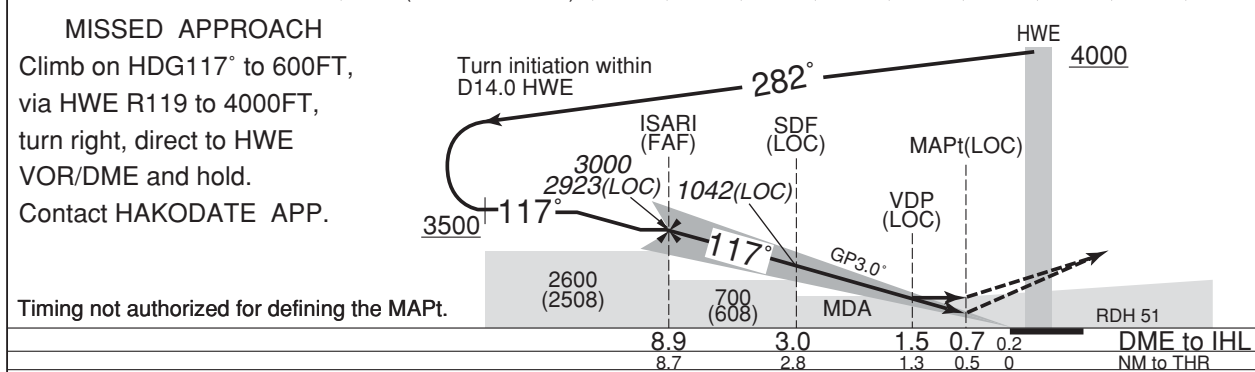

Missed APCH climb gradient MNM 5.0%

MINIMA		THR elev. 92	AD elev. 112			
CAT	CAT I		LOC	CIRCLING		
	DA(H)	RVR/CMV	MDA(H)	RVR/CMV	MDA(H) VIS	
A	292 (200)	700	540 (448)	1200	550 (438)	1600
B				1300	570 (458)	
C	299 (207)			1400	600 (488)	2400
D	309 (217)			1600	690 (578)	3200

Circling to SOUTH side of RWY only.
MINIMA with Missed APCH climb gradient of 2.5% are not established.

INSTRUMENT APPROACH CHART

RJCH / HAKODATE

RNAV(RNP) Y RWY30

HAKODATE APP 119.0 - 121.0 127.9	GNSS and RF required.	HAKODATE TWR 118.35 - 126.2	RADAR AVBL ATIS 126.6
--	-----------------------	--------------------------------	--------------------------

For uncompensated Baro-VNAV systems, procedure not authorized below -20°C / above 45°C

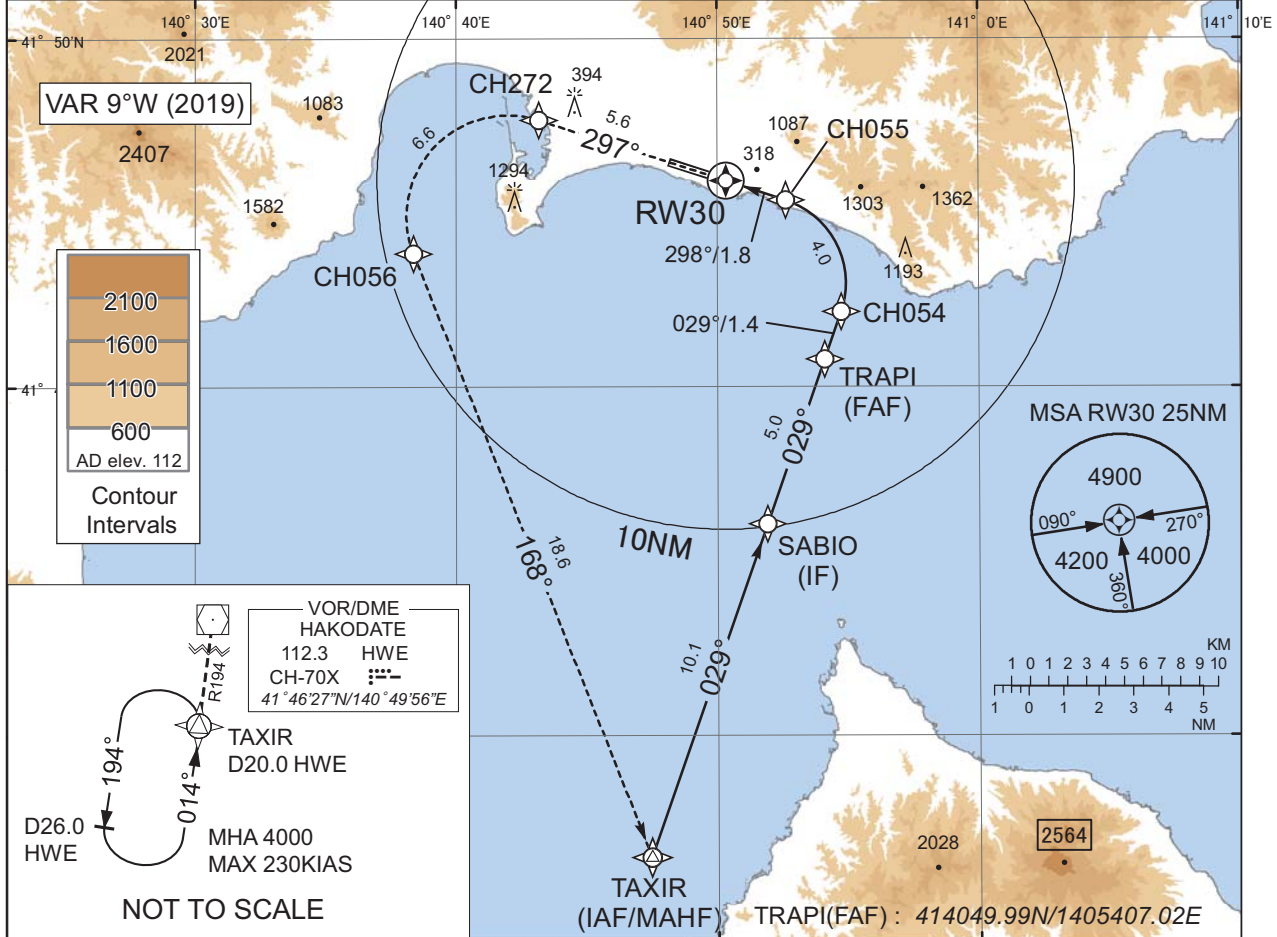

MISSED APPROACH

Climb to 4000FT, to CH272, to CH056 via fixed radius turn, to TAXIR and hold. Contact HAKODATE APP.

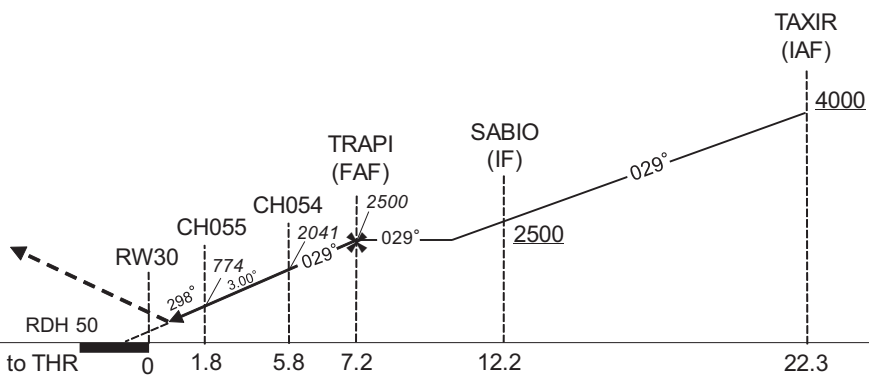

MINIMA	THR elev. 151	AD elev. 112
CAT	RNP 0.30	
	DA(H)	CMV
A	-	-
B	-	-
C	486(335)	1000
D	496(345)	1400

RNP AR

Special Authorization Required

CHANGE : VAR. PROC. HLDG Pattern. Minimum temperature.

INSTRUMENT APPROACH CHART

RJCH / HAKODATE

RNAV(RNP) Y RWY30

RNAV(RNP) Y RWY30

Coding Table

Serial Number	Path Descriptor	Waypoint Identifier	Fly Over	Course °M(°T)	Magnetic Variation	Distance (NM)	Turn Direction	Altitude (FT)	Speed (KIAS)	VPA/RDH (°/FT)	RNP Value
001	IF	TAXIR	-	-	-9.4	-	-	+4000	-	-	-
002	TF	SABIO	-	029 (019.2)	-9.4	10.1	-	+2500	-	-	1.0
003	TF	TRAPI	-	029 (019.2)	-9.4	5.0	-	2500	-	-	1.0
004	TF	CH054	-	029 (019.2)	-9.4	1.4	-	2041	-	-3.00	0.3
005	RF Center: CHRF3 r=2.50NM	CH055	-	-	-9.4	4.0	L	774	-	-3.00	0.3
006	TF	RW30	Y	298 (288.1)	-9.4	1.8	-	201	-	-3.00/50	0.3
007	TF	CH272	-	297 (288.1)	-9.4	5.6	-	-	-	-	1.0
008	RF Center: CHRF4 r=2.90NM	CH056	-	-	-9.4	6.6	L	-	-	-	1.0
009	TF	TAXIR	-	168 (158.5)	-9.4	18.6	-	4000	-	-	1.0

Waypoint Coordinates

Waypoint Identifier	Coordinates	RF Arc Center Identifier	Coordinates
TAXIR	412632.43N / 1404728.04E	CHRF3	414301.30N / 1405136.09E
SABIO	413606.58N / 1405154.81E	CHRF4	414456.26N / 1404159.49E
TRAPI	414049.99N / 1405407.02E		
CH054	414211.71N / 1405445.20E		
CH055	414524.03N / 1405238.26E		
RW30	414557.54N / 1405021.00E		
CH272	414742.10N / 1404311.31E		
CH056	414352.33N / 1403822.94E		

CHANGE : VAR. PROC.

INSTRUMENT APPROACH CHART

RJCH / HAKODATE

RNAV(RNP) RWY12

HAKODATE APP 119.0 - 121.0 127.9	GNSS and RF required.	HAKODATE TWR 118.35 - 126.2	RADAR AVBL ATIS 126.6
--	-----------------------	--------------------------------	--------------------------

For uncompensated Baro-VNAV systems, procedure not authorized below -20°C / above 45°C

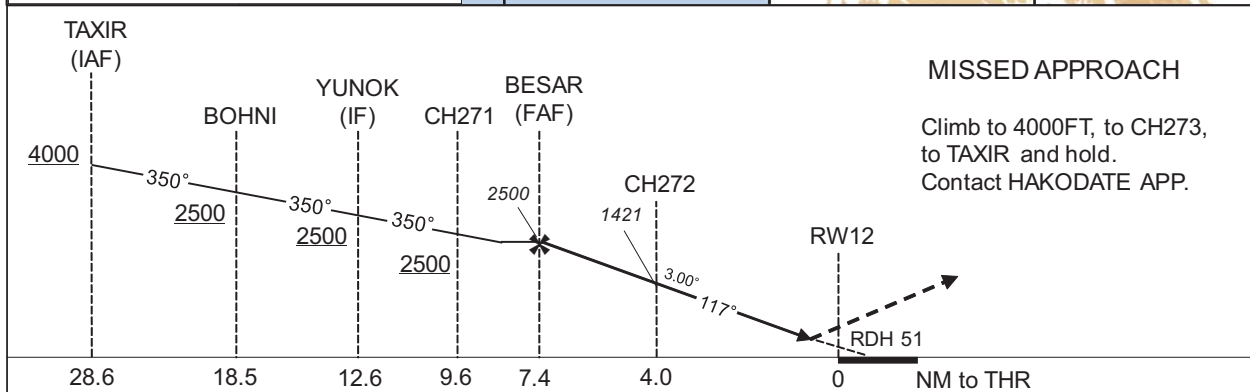
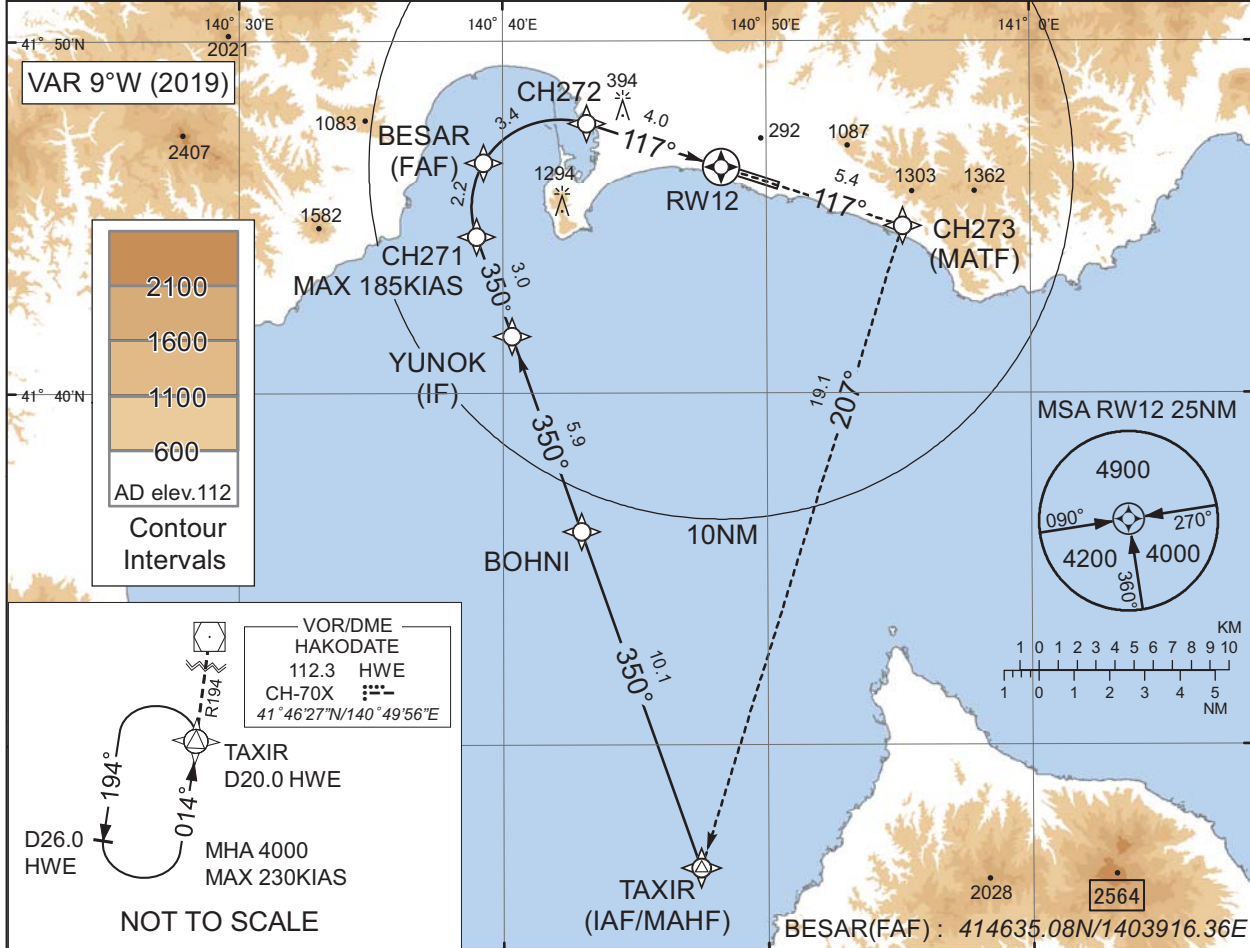

Missed APCH climb gradient MNM 5.0%

MINIMA	THR elev. 92	AD elev. 112
CAT	RNP 0.30	
	DA(H)	RVR/CMV
A	-	-
B	-	-
C	402(310)	1400
D	423(331)	1600

MINIMA with Missed APCH climb gradient of 2.5% are not established.

RNP AR
Special Authorization Required

CHANGE : New PROC.

INSTRUMENT APPROACH CHART

RJCH / HAKODATE

RNAV(RNP) RWY12

RNAV(RNP) RWY12											
Coding Table											
Serial Number	Path Descriptor	Waypoint Identifier	Fly Over	Course °M(°T)	Magnetic Variation	Distance (NM)	Turn Direction	Altitude (FT)	Speed (KIAS)	VPA/ RDH (°/FT)	RNP Value
001	IF	TAXIR	-	-	-9.4	-	-	+4000	-	-	-
002	TF	BOHNI	-	350 (340.6)	-9.4	10.1	-	+2500	-	-	1.0
003	TF	YUNOK	-	350 (340.6)	-9.4	5.9	-	+2500	-	-	1.0
004	TF	CH271	-	350 (340.5)	-9.4	3.0	-	+2500	-185	-	1.0
005	RF Center: CHRF5 r=2.50NM	BESAR	-	-	-9.4	2.2	R	2500	-	-	1.0
006	RF Center: CHRF5 r=2.50NM	CH272	-	-	-9.4	3.4	R	1421	-	-3.00	0.3
007	TF	RW12	Y	117 (108.0)	-9.4	4.0	-	143	-	-3.00/51	0.3
008	TF	CH273	-	117 (108.1)	-9.4	5.4	-	-	-	-	1.0
009	TF	TAXIR	-	207 (197.6)	-9.4	19.1	-	4000	-	-	1.0
Waypoint Coordinates											
Waypoint Identifier	Coordinates		RF Arc Center Identifier	Coordinates							
TAXIR	412632.43N / 1404728.04E		CHRF5	414519.29N / 1404209.46E							
BOHNI	413606.23N / 1404258.19E										
YUNOK	414139.34N / 1404020.87E										
CH271	414429.13N / 1403900.50E										
BESAR	414635.08N / 1403916.36E										
CH272	414742.10N / 1404311.31E										
RW12	414627.62N / 1404817.61E										
CH273	414446.88N / 1405510.13E										

CHANGE : New PROC.

INSTRUMENT APPROACH CHART

RJCH / HAKODATE

VOR RWY30

HAKODATE APP 119.0 – 121.0 127.9	HAKODATE VOR/DME 112.3 HWE CH-70X 41°46'27"N/140°49'56"E	HAKODATE TOWER 118.35 – 126.2	RADAR AVBL ATIS 126.6
--	---	----------------------------------	--------------------------

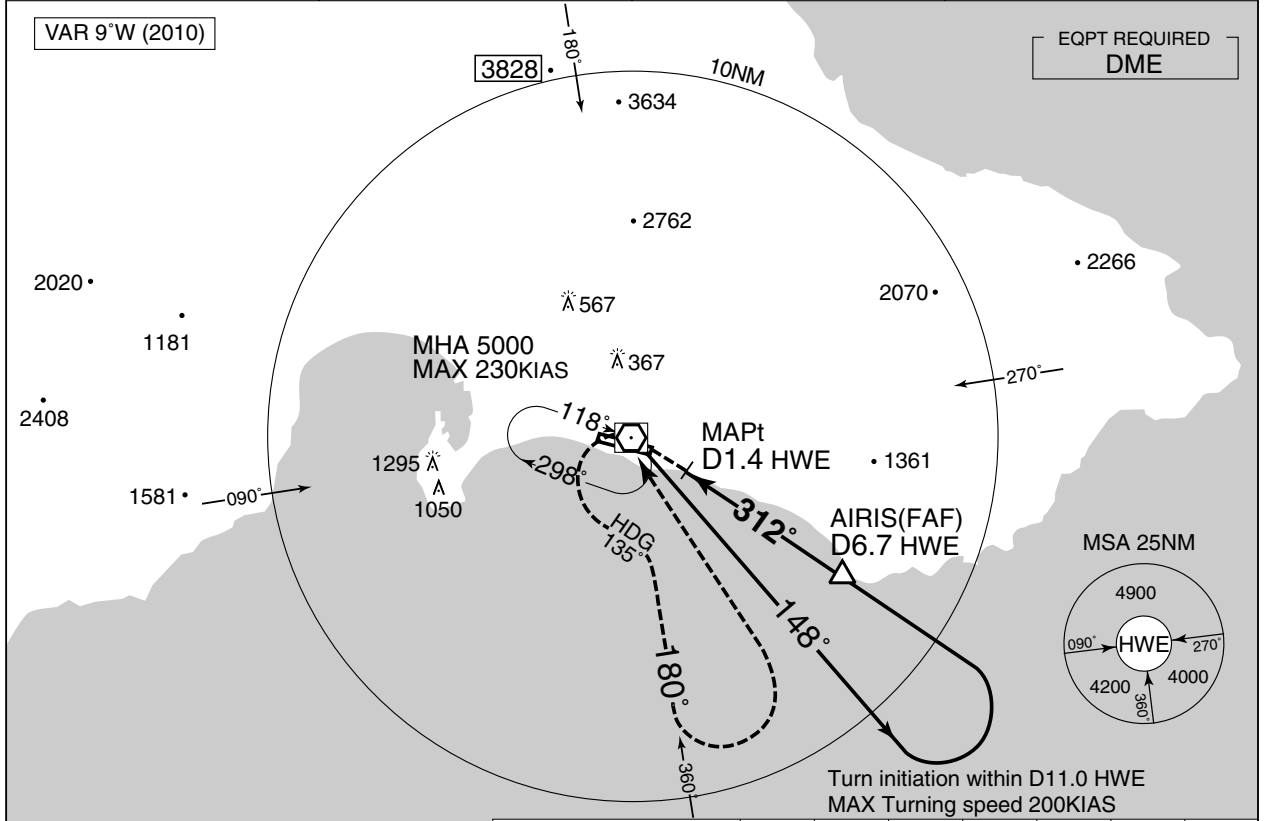

NM to HWE	MAPt	2	3	4	5	6	FAF
ALT (3.5° APCH Path)	-	750	1122	1494	1865	2237	2497

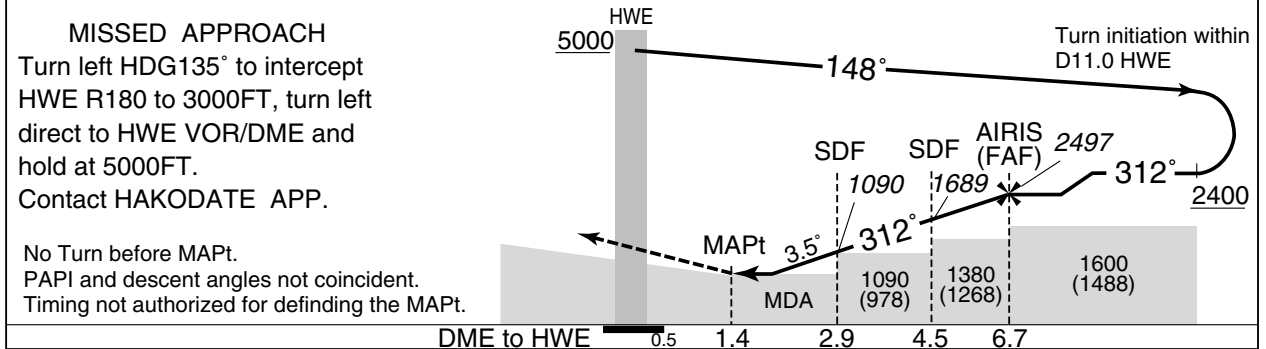

MINIMA		THR elev. 151	AD elev. 112	
CAT			CIRCLING	
	MDA(H)	CMV	MDA(H)	VIS
A	730 (618)	1000	730 (618)	1600
B		1200		2400
C		1600		3200
D				

Circling to SOUTH side of RWY only.

INSTRUMENT APPROACH CHART

RJCH / HAKODATE

VOR RWY12

HAKODATE APP 119.0 – 121.0 127.9	HAKODATE VOR/DME 112.3 HWE CH-70X 41°46'27"N/140°49'56"E	HAKODATE TOWER 118.35 – 126.2	RADAR AVBL ATIS 126.6
--	---	----------------------------------	--------------------------

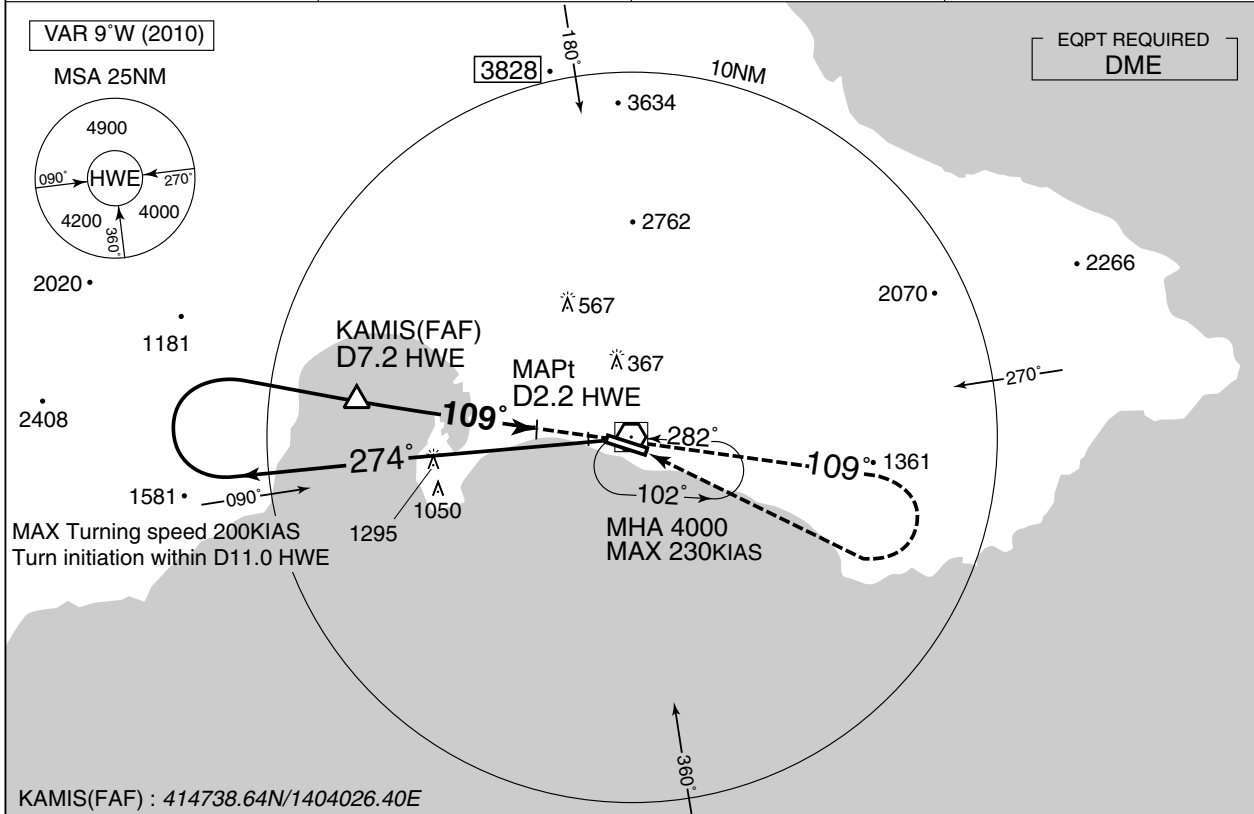

NM to HWE	FAF	7	6	5	4	3	MAPt
ALT (3.5° APCH Path)	2362	2293	1922	1550	1178	807	-

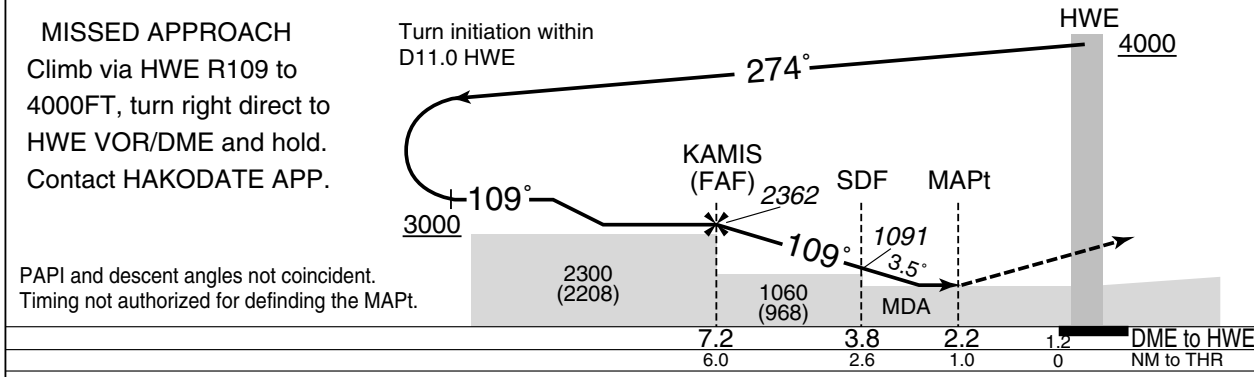

Missed APCH climb gradient MNM 3.6%

MINIMA		THR elev. 92	AD elev. 112	
CAT	MDA(H)		CIRCLING	
	RVR/CMV	MDA(H)	VIS	
A	530 (438)	1200	550 (438)	1600
B		1300	570 (458)	
C		1400	600 (488)	
D		1600	690 (578)	

Circling to SOUTH side of RWY only.
MINIMA with Missed APCH climb gradient of 2.5% are not established.

RJCH / HAKODATE

Visual REP

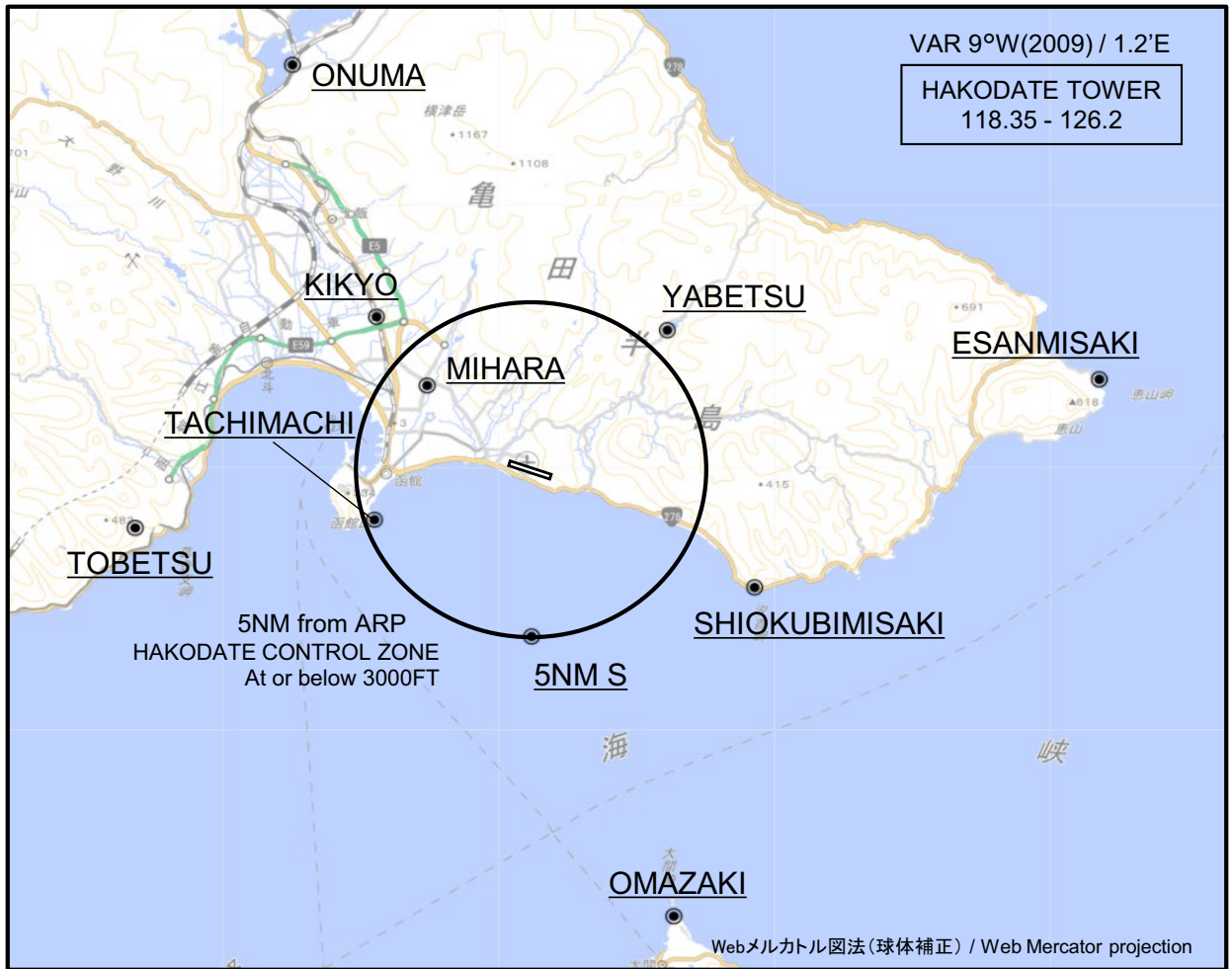

※図中に標高を示す数字がある場合、単位はメートル(m)である。The unit of measurement used to express elevation is meter(m).

CHANGE :DIST from ARP(Mihara):

Call sign	BRG / DIST from ARP	Remarks
大沼 Onuma	330°T / 13.9NM	JR駅 JR Station
桔梗 Kikyo	316°T / 6.4NM	JR駅 JR Station
矢別 Yabetsu	043°T / 5.7NM	ダム Dam
恵山岬 Esanmisaki	081°T / 16.5NM	灯台 Lighthouse
美原 Mihara	310°T / 3.9NM	NHKラジオアンテナ NHK radio antenna
立待 Tachimachi	252°T / 4.8NM	岬 Cape
当別 Tobetsu	261°T / 11.5NM	トラピスト修道院 Religious house
汐首岬 Shiokubimisaki	119°T / 7.3NM	灯台 Lighthouse
5NM S	180°T / 5.0NM	海上 Over the sea
大間崎 Omazaki	163°T / 14.0NM	岬 Cape

AIRCRAFT PARKING/DOCKING CHART

RJCH / HAKODATE

AD CHART

HAKODATE AIRPORT
ELEV34.1m (111.9ft)

Designation	Call Sign	Frequency (MHz)
ATIS	Hakodate Airport	126.6
TWR	Hakodate Tower	118.35 258.3 126.2

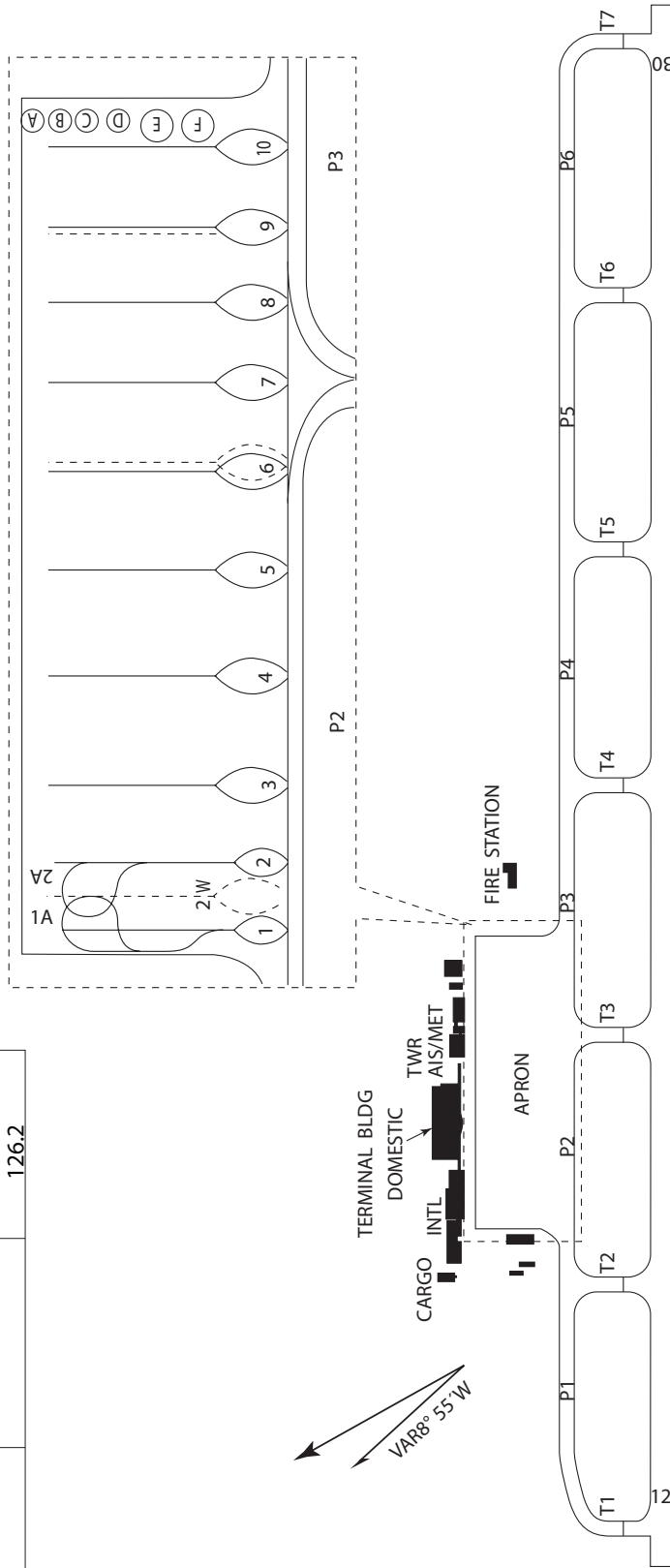

LDG CHART

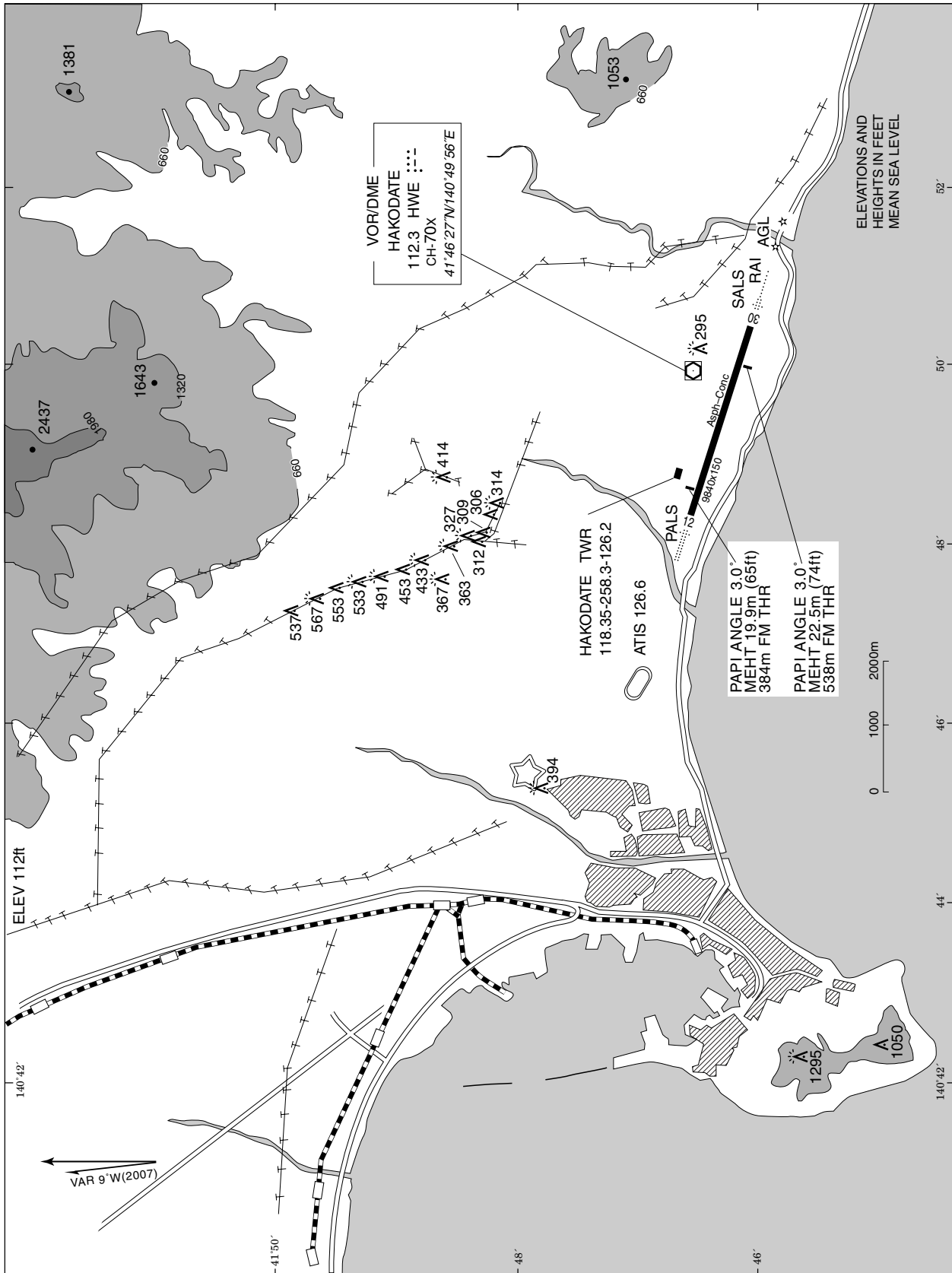

STANDARD DEPARTURE CHART - INSTRUMENT

RJCH / HAKODATE RNAV SID and TRANSITION

TSUGARU ONE DEPARTURE KOMACHI TRANSITION		RNAV1
Note 1) DME/DME/IRU or GNSS required. ※The aircraft equipped with only DME/DME/IRU must be able to update its position without delay at the starting point of take-off roll. 2) RADAR service required.	Critical DME	RWY12 : MRE : 30.0NM to TAPPI – TAPPI RWY30 : MRE : 47.6NM to TAPPI – TAPPI HWE : 47.6NM to TAPPI – 40.0NM to TAPPI KOMACHI Transition : MRE: TAPPI - 24.0NM to UWE HWE: TAPPI - 55.0NM to UWE UWE: 55.0NM to UWE - 24.0NM to UWE HPE: 16.0NM to UWE - UWE
	DME GAP	RWY12 : RWY12DER – 30.0NM to TAPPI RWY30 : RWY30DER – 47.6NM to TAPPI KOMACHI Transition: 24.0NM to UWE – 22.0NM to UWE 19.0NM to UWE – 16.0NM to UWE
	Inappropriate Nav aids	See AD1.1.6.10.3. Inappropriate NAVAIDs for RNAV1

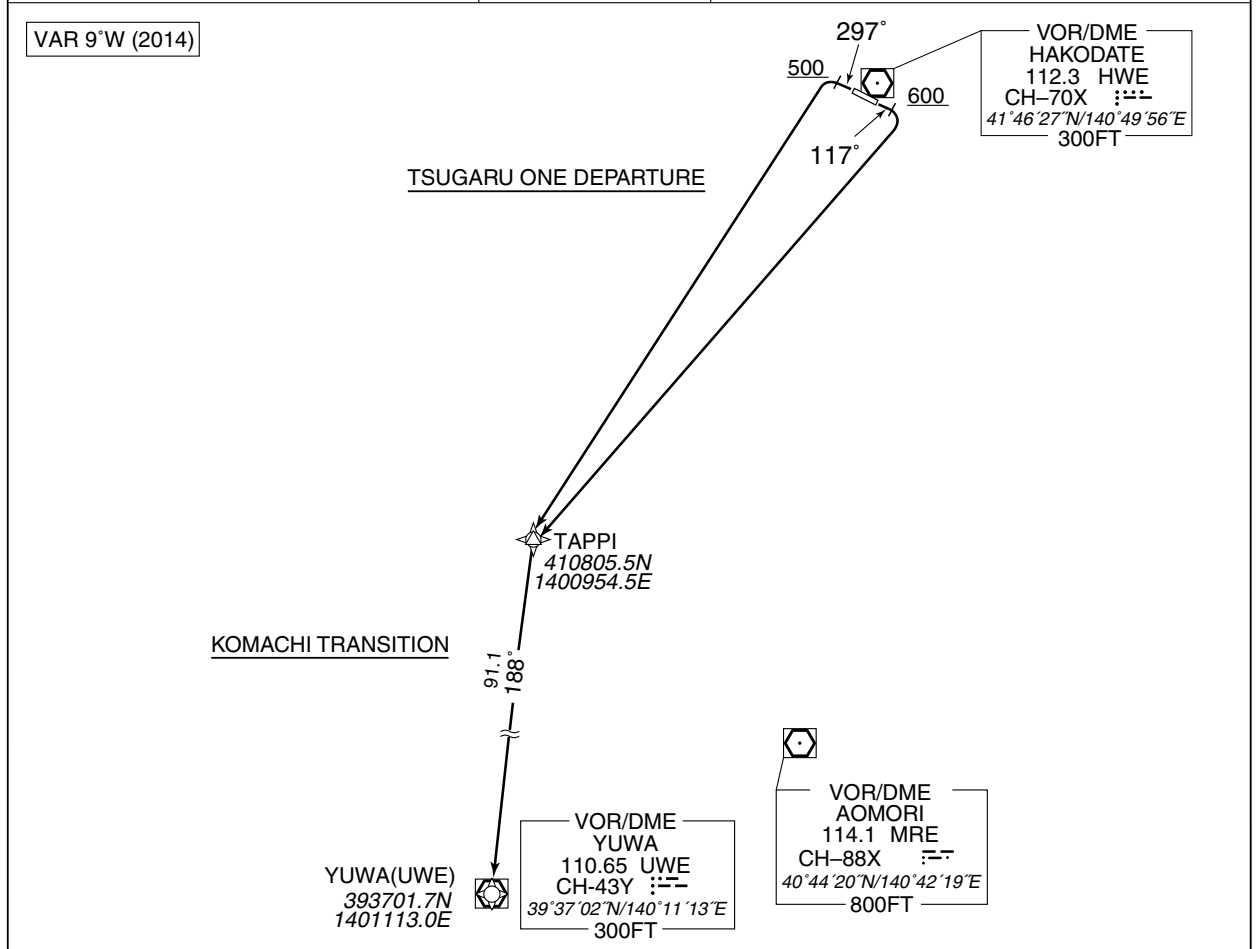

<p>TSUGARU ONE DEPARTURE</p> <p>RWY12 : Climb on HDG117° at or above 600FT, turn right direct to TAPPI. RWY30 : Climb on HDG297° at or above 500FT, turn left direct to TAPPI.</p> <p>NOTE RWY12 : 4.0% climb gradient required up to 1300FT. OBST ALT 919FT located at 3.43NM 105° FM end of RWY12. RWY30 : 5.4% climb gradient required up to 1600FT. OBST ALT 1296FT located at 4.63NM 267° FM end of RWY30.</p>
<p>KOMACHI TRANSITION From TAPPI, to UWE.</p>

STANDARD DEPARTURE CHART - INSTRUMENT

RJCH / HAKODATE

RNAV SID and TRANSITION

TSUGARU ONE DEPARTURE

RWY12

Serial Number	Path Descriptor	Waypoint Identifier	Fly Over	Course °M(°T)	Magnetic Variation	Distance (NM)	Turn Direction	Altitude (FT)	Speed (KIAS)	Vertical Angle	Navigation Specification
001	VA	—	—	117 (108.0)	-8.9	—	—	+600	—	—	RNAV1
002	DF	TAPPI	—	—	-8.9	—	R	—	—	—	RNAV1

RWY30

Serial Number	Path Descriptor	Waypoint Identifier	Fly Over	Course °M(°T)	Magnetic Variation	Distance (NM)	Turn Direction	Altitude (FT)	Speed (KIAS)	Vertical Angle	Navigation Specification
001	VA	—	—	297 (288.1)	-8.9	—	—	+500	—	—	RNAV1
002	DF	TAPPI	—	—	-8.9	—	L	—	—	—	RNAV1

KOMACHI TRANSITION

Serial Number	Path Descriptor	Waypoint Identifier	Fly Over	Course °M(°T)	Magnetic Variation	Distance (NM)	Turn Direction	Altitude (FT)	Speed (KIAS)	Vertical Angle	Navigation Specification
001	IF	TAPPI	—	—	-8.9	—	—	—	—	—	RNAV1
002	TF	UWE	—	188 (179.4)	-8.9	91.1	—	—	—	—	RNAV1

INSTRUMENT APPROACH CHART

RJCH / HAKODATE

RNAV(GNSS) Z RWY30

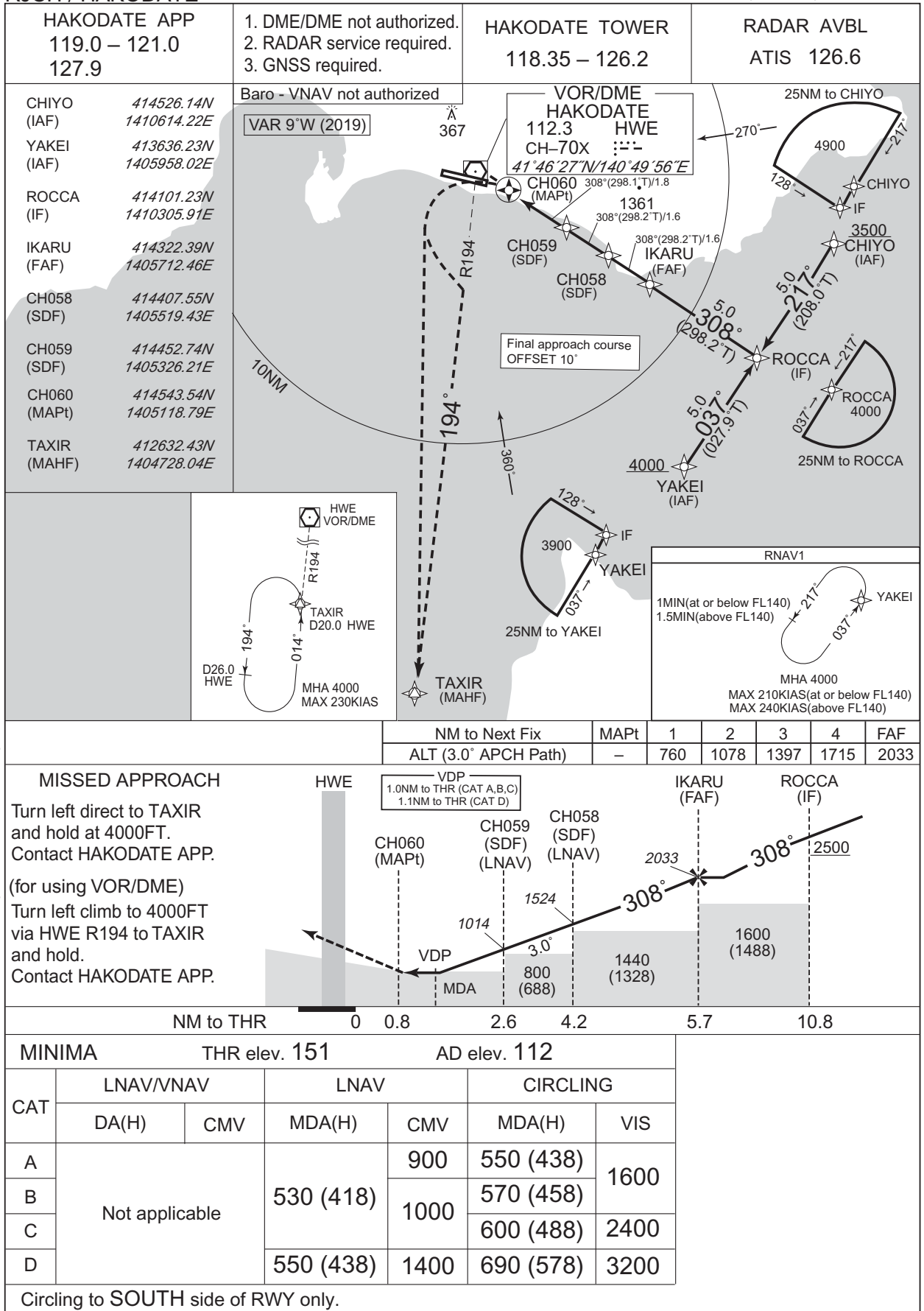

CHANGE : VAR. PROC. HLDG Pattern(TAXIR,YAKEI) established.

RJCH / HAKODATE

Minimum Vectoring Altitude CHART

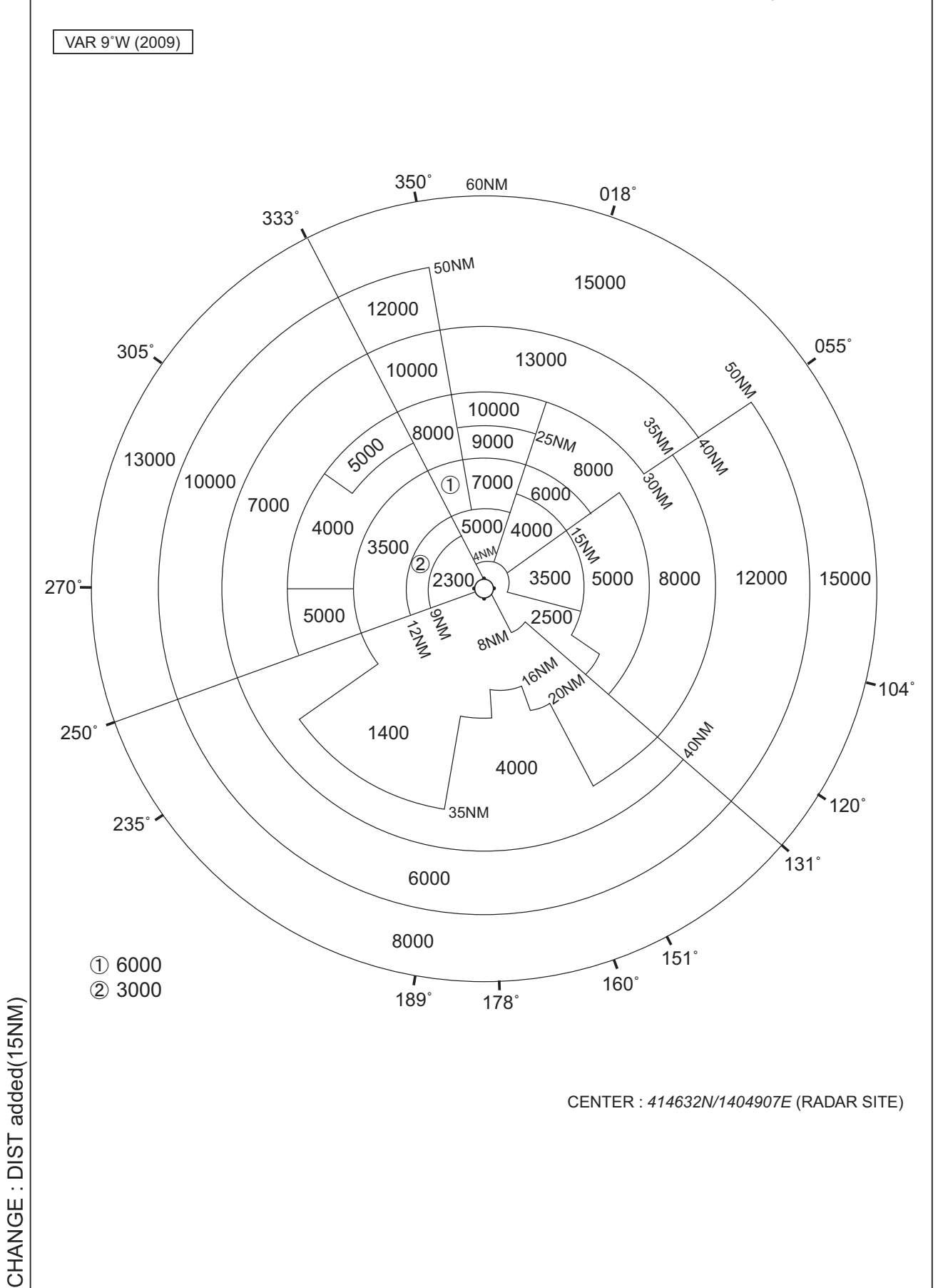

INTENTIONALLY LEFT BLANK

AERODROME OBSTACLE CHART - ICAO
TYPE A (OPERATING LIMITATIONS)

DIMENSIONS AND ELEVATIONS IN FEET, BEARINGS ARE MAGNETIC

MAGNETIC VARIATION 9° W-APR 2018

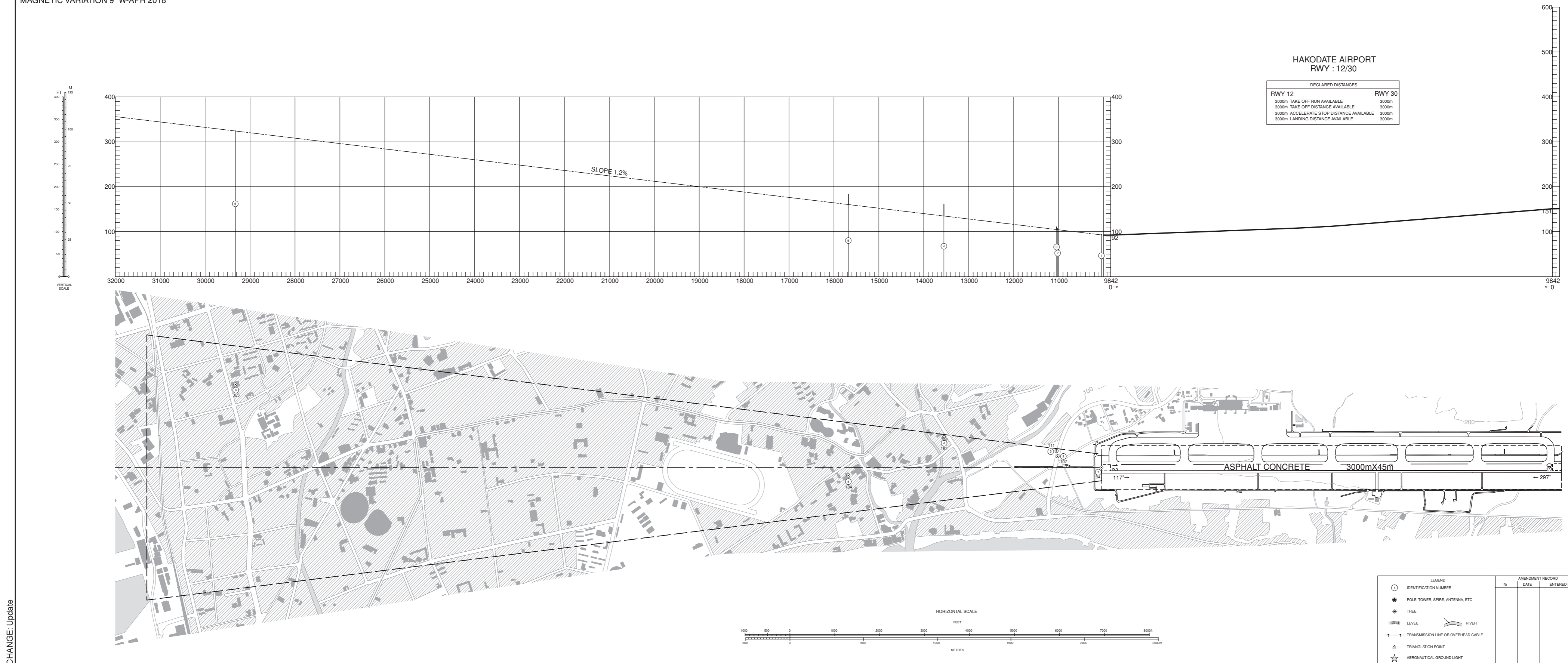

CHANGE: Update

AERODROME OBSTACLE CHART - ICAO
TYPE A (OPERATING LIMITATIONS)

DIMENSIONS AND ELEVATIONS IN FEET, BEARINGS ARE MAGNETIC

MAGNETIC VARIATION 9° W-APR 2018

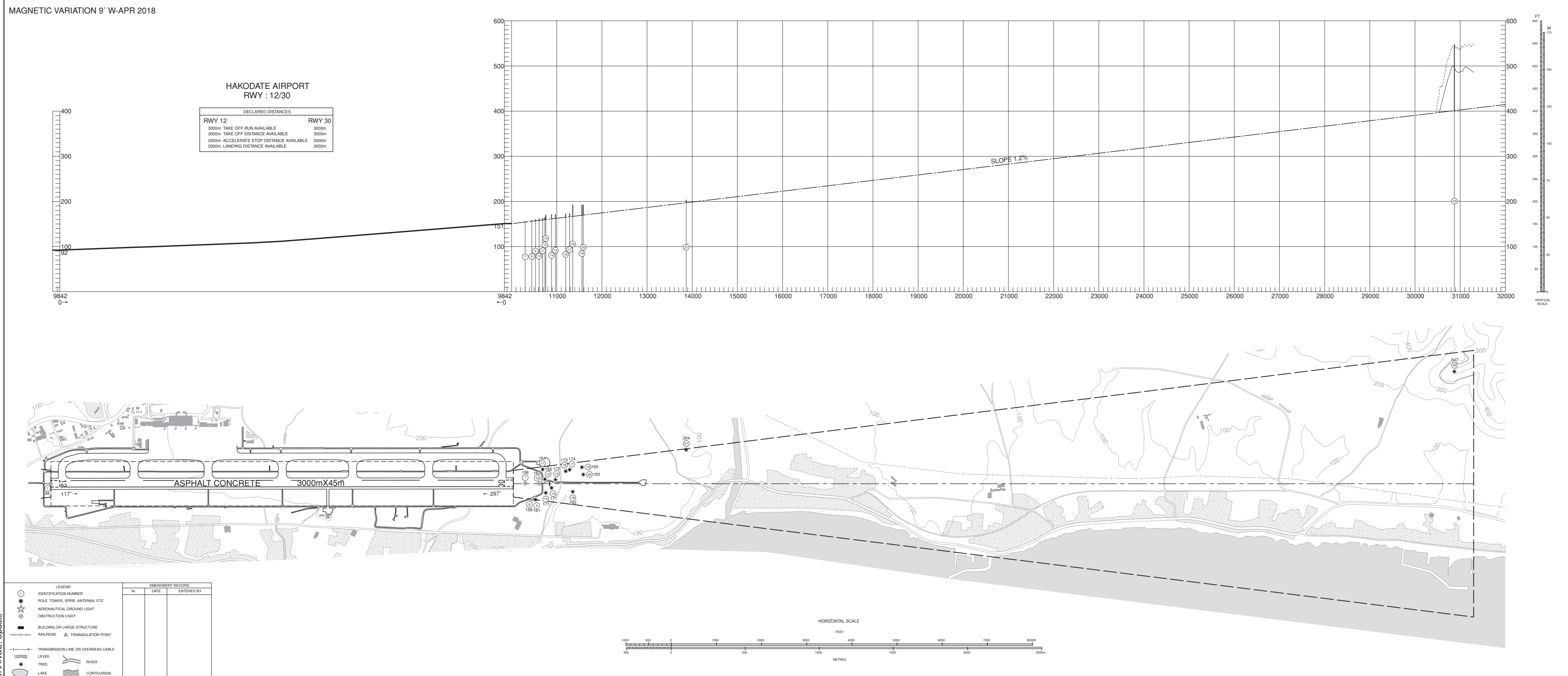

AERODROME OBSTACLE CHART - ICAO
TYPE B

DIMENSIONS AND ELEVATIONS IN FEET, BEARINGS ARE MAGNETIC

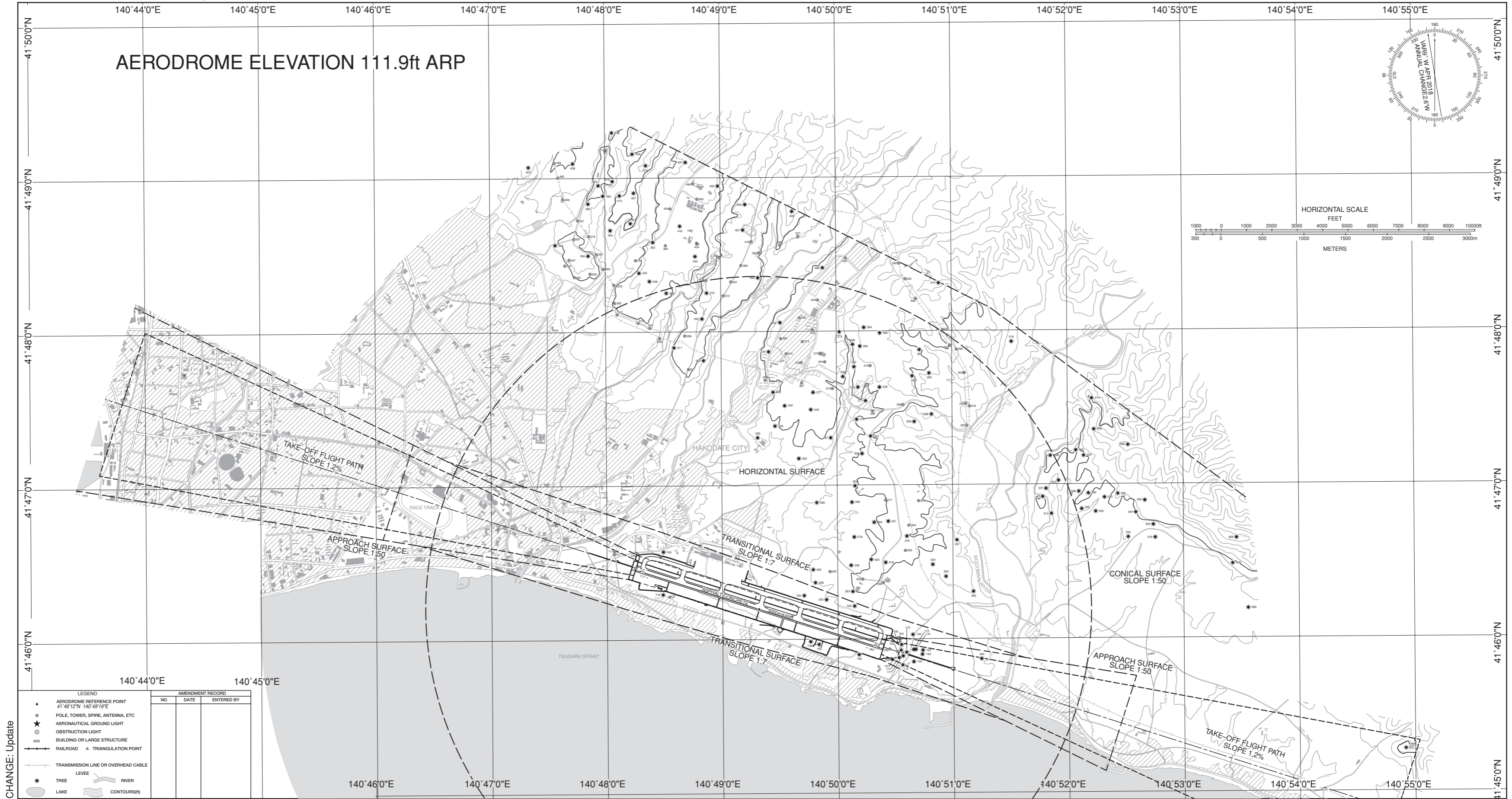

STANDARD DEPARTURE CHART - INSTRUMENT

RJCH / HAKODATE

SID and TRANSITION

HAKODATE SOUTH SEVEN DEPARTURE

RWY 12: Climb RWY HDG until 600FT, turn right HDG239°...

RWY 30: Climb RWY HDG until 500FT, turn left HDG149°...

...to intercept and proceed via HWE R194 to MRE VOR/DME.

Cross HWE R194/30.0DME at or above 6000FT.

Note RWY12 : 4.0% climb gradient required up to 1300FT.

OBST ALT 919FT located at 3.43NM 105° FM end of RWY12.

RWY30 : 5.4% climb gradient required up to 1600FT.

OBST ALT 1296FT located at 4.63NM 267° FM end of RWY30.

HAKODATE REVERSAL FIVE DEPARTURE

RWY 12: Climb RWY HDG until 600FT, turn right HDG239°...

RWY 30: Climb RWY HDG until 500FT, turn left HDG149°...

...to intercept and proceed via HWE R194 to 3000FT, turn right direct to HWE VOR/DME.

Cross HWE VOR/DME at or above 5000FT.

Note RWY12 : 4.0% climb gradient required up to 1300FT.

OBST ALT 919FT located at 3.43NM 105° FM end of RWY12.

RWY30 : 5.4% climb gradient required up to 1600FT.

OBST ALT 1296FT located at 4.63NM 267° FM end of RWY30.

TAPPI SEVEN DEPARTURE

RWY 12: Climb RWY HDG until 600FT, turn right HDG272°...

RWY 30: Climb RWY HDG until 500FT, turn left HDG182°...

...to intercept and proceed via HWE R227 to TAPPI. Cross TAPPI at or above FL170.

Note RWY12 : 4.0% climb gradient required up to 1300FT.

OBST ALT 919FT located at 3.43NM 105° FM end of RWY12.

RWY30 : 5.4% climb gradient required up to 1600FT.

OBST ALT 1296FT located at 4.63NM 267° FM end of RWY30.

YUWA TRANSITION

From over TAPPI, proceed via UWE R008 to UWE VOR/DME.

Cross UWE R008/21.0DME at assigned altitude.

ESASI SIX DEPARTURE

RWY 12: Climb RWY HDG until 600FT, turn right HDG340°...

RWY 30: Climb RWY HDG until 700FT, turn right,...

...to intercept and proceed via HWE R295 to ESASI.

Cross ESASI at or above 5000FT.

Note RWY12 : 4.9% climb gradient required up to 1300FT.

OBST ALT 919FT located at 3.43NM 105° FM end of RWY12.

TIKYU ONE DEPARTURE

RWY 12: Climb RWY HDG until 600FT, turn left,...

RWY 30: Climb RWY HDG until 600FT, turn left HDG073°...

...to intercept and proceed via HWE R118 to TIKYU.

Cross TIKYU at or above 6000FT.

Note RWY12 : 6.3% climb gradient required up to 1700FT.

OBST ALT 1302FT located at 4.03NM 101° FM end of RWY12.

RWY30 : 5.4% climb gradient required up to 1600FT.

OBST ALT 1296FT located at 4.63NM 267° FM end of RWY30.

CHANGE : ESASI SIX DEPARTURE.

STANDARD DEPARTURE CHART - INSTRUMENT

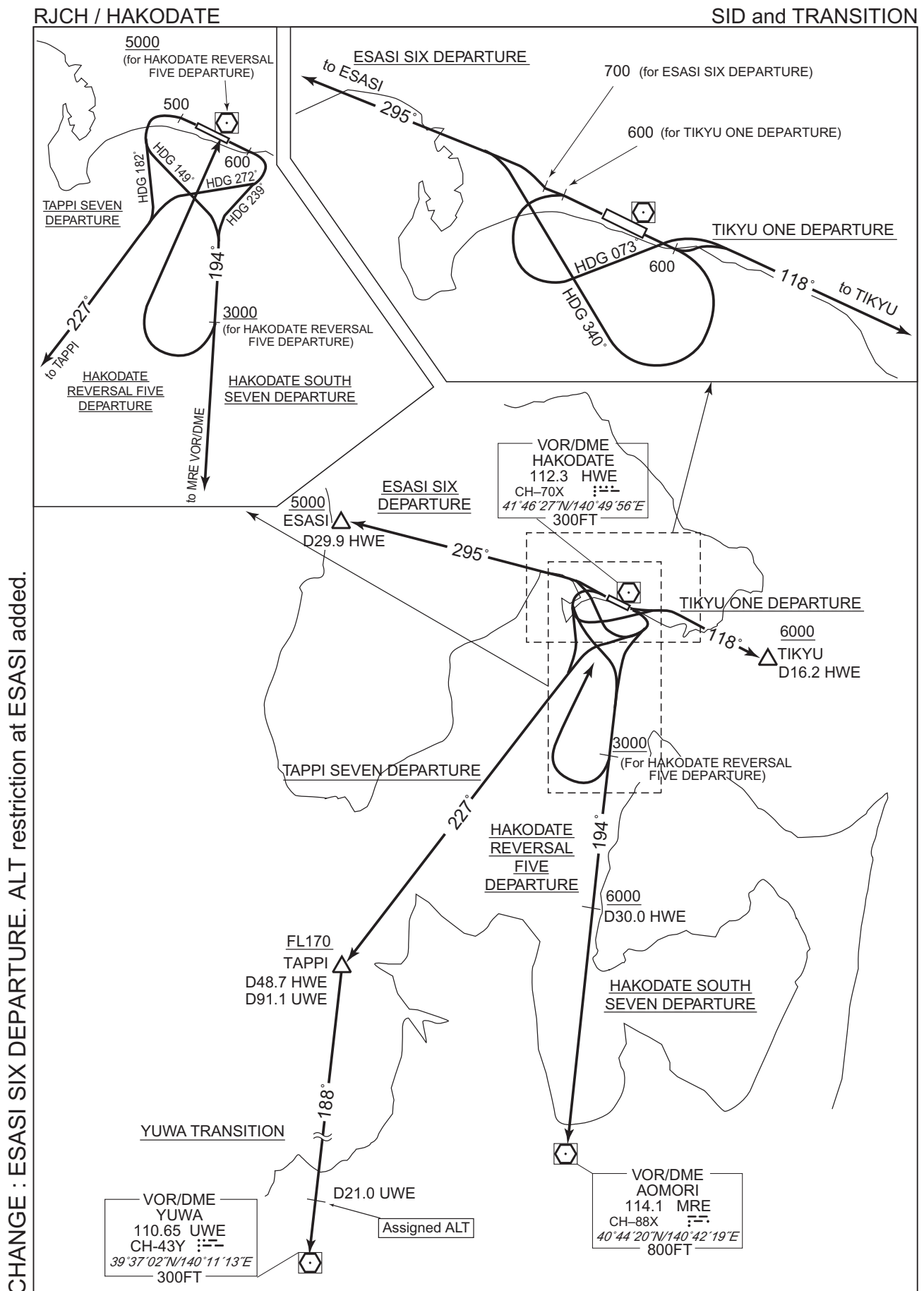

CHANGE : ESASI SIX DEPARTURE. ALT restriction at ESASI added.

STANDARD ARRIVAL CHART - INSTRUMENT

RJCH / HAKODATE RNAV STAR RWY30

YAKEI ARRIVAL

RNAV1

Note 1) DME/DME/IRU or GNSS required
2) RADAR service required

VAR 9°W (2019)

VOR/DME
HAKODATE
112.3 HWE
CH-70X
41°46'27"N/140°49'56"E
300FT

YAKEI ARRIVAL

YAKEI
413636.2N
1405958.0E
4000

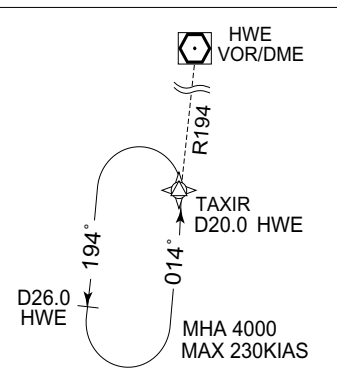

TAXIR
412632.4N
1404728.0E
6000

YAKEI ARRIVAL

From TAXIR at or above 6000FT, to YAKEI at or above 4000FT.

Critical DME	MKE : TAXIR – 10.0NM to YAKEI HWE : 3.0NM to YAKEI – YAKEI
DME GAP	—
Inappropriate Nav aids	See AD1.1.6.10.3. Inappropriate NAVAIDs for RNAV1

Serial Number	Path Descriptor	Waypoint Identifier	Fly Over	Course °M(°T)	Magnetic Variation	Distance (NM)	Turn Direction	Altitude (FT)	Speed (KIAS)	Vertical Angle	Navigation Specification
001	IF	TAXIR	—	—	-9.4	—	—	+6000	—	—	RNAV1
002	TF	YAKEI	—	052 (042.9)	-9.4	13.8	—	+4000	—	—	RNAV1

CHANGE : New PROC.

STANDARD ARRIVAL CHART - INSTRUMENT

RJCH / HAKODATE RNAV STAR RWY12

PATRA ARRIVAL

RNAV1

Note 1) DME/DME/IRU or GNSS required
2) RADAR service required

VAR 9°W (2019)

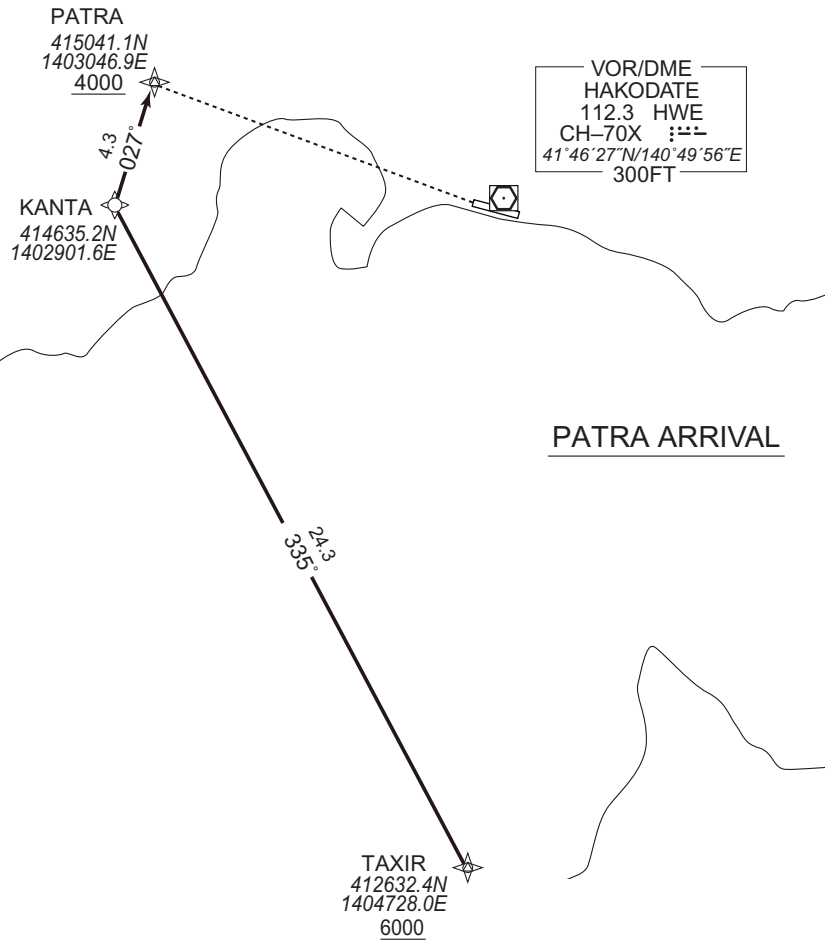

PATRA ARRIVAL

PATRA ARRIVAL

From TAXIR at or above 6000FT, to KANTA, to PATRA at or above 4000FT.

Critical DME	MRE : 18.0NM to KANTA – KANTA HWE : 2.2NM to KANTA – KANTA
DME GAP	KANTA – PATRA
Inappropriate Nav aids	See AD1.1.6.10.3. Inappropriate NAV AIDs for RNAV1

Serial Number	Path Descriptor	Waypoint Identifier	Fly Over	Course °M(°T)	Magnetic Variation	Distance (NM)	Turn Direction	Altitude (FT)	Speed (KIAS)	Vertical Angle	Navigation Specification
001	IF	TAXIR	—	—	-9.4	—	—	+6000	—	—	RNAV1
002	TF	KANTA	—	335 (325.6)	-9.4	24.3	—	—	—	—	RNAV1
003	TF	PATRA	—	027 (017.7)	-9.4	4.3	—	+4000	—	—	RNAV1

CHANGE : Correction of misdescription(Name of PROC).

函館進入管制区
Hakodate Approach Control Area

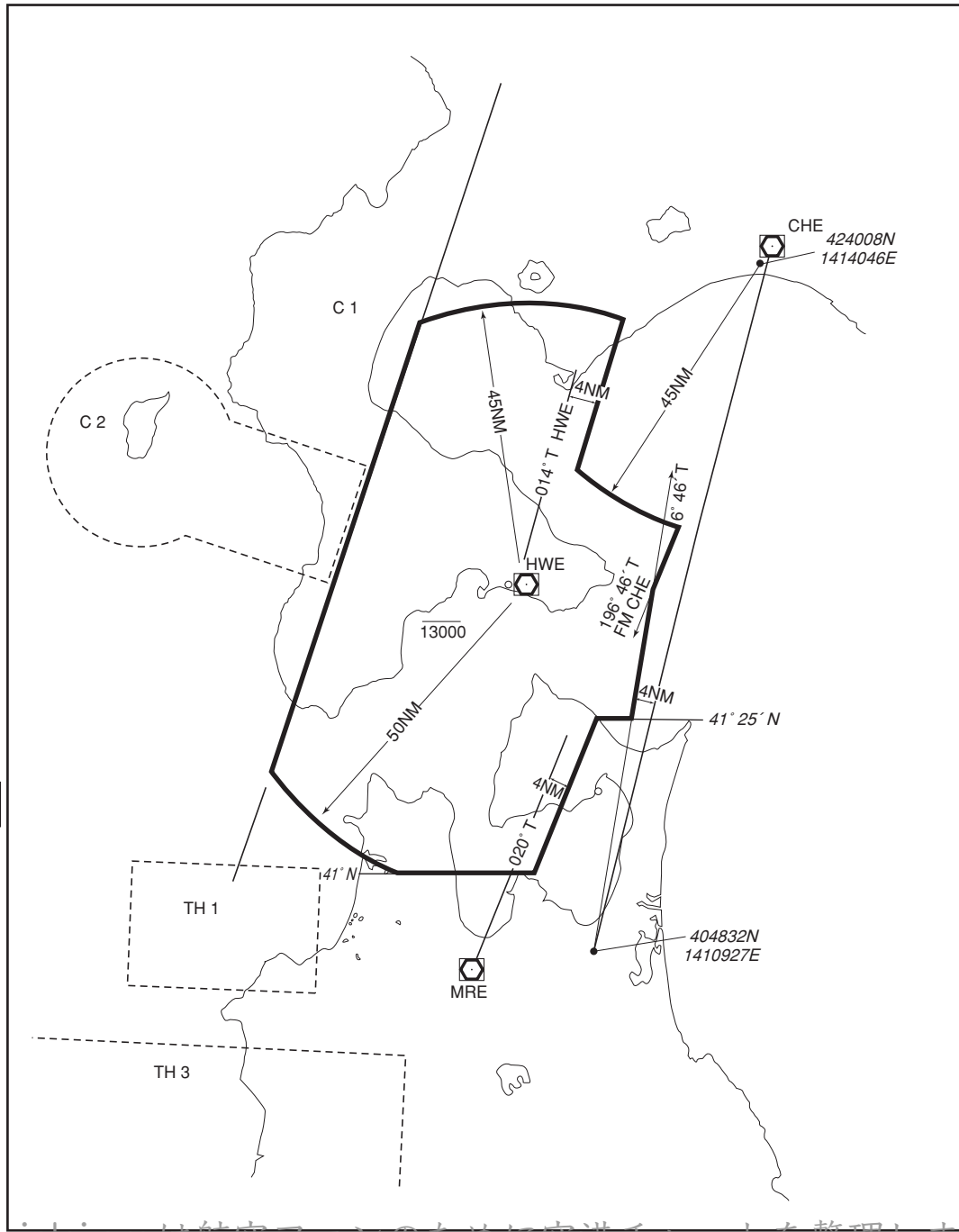

ILS for RWY12

HAKODATE AP

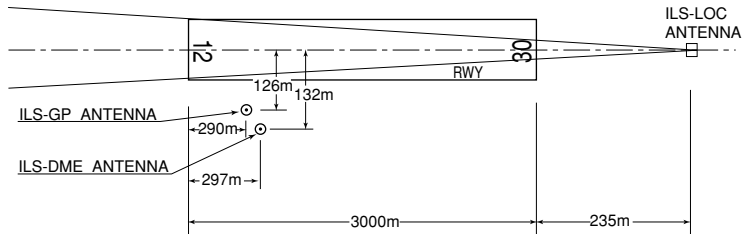

REMARKS : 1.ILS-LOC beam(BRG) 117°
2.ILS-GP Angle 3.0°
3.HGT of ILS REF datum 15.5m(51.0ft)
4.ELEV of ILS-DME 33.9m(111ft)