

AD 2 AERODROMES

RJBD AD 2.1 AERODROME LOCATION INDICATOR AND NAME

RJBD - NANKI SHIRAHAMA

RJBD AD 2.2 AERODROME GEOGRAPHICAL AND ADMINISTRATIVE DATA

1	ARP coordinates and site at AD	333944N/1352152E 1.0km from RWY THR
2	Direction and distance from (city)	4.1NM S from TANABE
3	Elevation/ Reference temperature	293ft / 31°C (2012-2016)
4	Geoid undulation at AD ELEV PSN	124ft
5	MAG VAR/ Annual change	8°W(2020) / 4'W
6	AD Administration, address, telephone, telefax, telex, AFS, e-mail and/or Web-site addresses	NANKI SHIRAHAMA AIRPORT CO., LTD. 1622-125 Saino, Shirahama-cho, Nishimuro-gun, Wakayama Pref. Tel:0739-43-0095 Fax:0739-43-0091
7	Types of traffic permitted (IFR/VFR)	IFR/VFR
8	Remarks	Civil Aviation Bureau, MLIT Nankishirahama Airport branch 2926 Shirahama-cho, Nishimuro-gun, Wakayama Pref. Tel : 0739-42-3827

RJBD AD 2.3 OPERATIONAL HOURS

1	AD Administration	2330 - 1100
2	Customs and immigration	On request Customs: 073-492-0280 Immigration: 073-422-8778
3	Health and sanitation	Quarantine(human): On request(06-6571-4312) Quarantine(animal, plant): Nil
4	AIS Briefing Office	Nil
5	ATS Reporting Office(ARO)	Nil
6	MET Briefing Office	H24 (KANSAI)
7	ATS	2330 - 1100
8	Fuelling	Ask AD administration
9	Handling	Ask AD administration
10	Security	Ask AD administration
11	De-icing	Not Available
12	Remarks	Nil

RJBD AD 2.4 HANDLING SERVICES AND FACILITIES

1	Cargo-handling facilities	Up to 5t or less
2	Fuel/ oil types	JET A-1, 100
3	Fuelling facilities/ capacity	Fuel truck / Not limitation
4	De-icing facilities	Nil
5	Hangar space for visiting aircraft	Ask AD administration
6	Repair facilities for visiting aircraft	Nil
7	Remarks	Unable cargo container

RJBD AD 2.5 PASSENGER FACILITIES

1	Hotels	Hotels in the city
2	Restaurants	At Airport
3	Transportation	Busses, taxis
4	Medical facilities	Nil
5	Bank and Post Office	Nil
6	Tourist Office	Nil
7	Remarks	Nil

RJBD AD 2.6 RESCUE AND FIRE FIGHTING SERVICES

1	AD category for fire fighting	CAT 7
2	Rescue equipment	Chemical fire fighting truck x 2 Emergency medical equipments conveyance truck x 1
3	Capability for removal of disabled aircraft	Nil
4	Remarks	Nil

RJBD AD 2.7 SEASONAL AVAILABILITY-CLEARING

1	Types of clearing equipment	Not applicable
2	Clearance priorities	Nil
3	Remarks	Nil

RJBD AD 2.8 APRONS, TAXIWAYS AND CHECK LOCATIONS DATA

1	Apron surface and strength	SOUTH : Surface : Cement-concrete Strength : PCN 52/R/B/X/T NORTH : Surface : Asphalt-concrete Strength :AUW 5700kg/0.28Mpa
2	Taxiway width, surface and strength	Surface : Asphalt-concrete WIDTH & STRENGTH S-T : 30m PCN 42/F/A/X/T N-T : 9m AUW 5700kg/0.28Mpa
3	ACL and elevation	Not available
4	VOR checkpoints	Not available
5	INS checkpoints	Spot NR 1: 333945.11N 1352140.42E 2: 333945.62N 1352138.79E 3: 333947.66N 1352137.95E N-2: 333954.93N 1352136.20E N-4: 333956.33N 1352135.43E
6	Remarks	Nil

RJBD AD 2.9 SURFACE MOVEMENT GUIDANCE AND CONTROL SYSTEM AND MARKINGS

1	Use of aircraft stand ID signs, TWY guide lines and Visual docking/ parking guidance system of aircraft stands	Nil
2	RWY and TWY markings and LGT	RWY:15/33 (Marking) RWY designation, RWY CL, RWY THR, RWY middle point, Aiming point, TDZ, RWY side stripe, RWY turn pad edge, RWY turn pad CL (LGT) RCLL, REDL, RTHL, RENL, Turning point indicator LGT TWY:ALL TWY (Marking) TWY CL, RWY HLDG PSN, TWY side stripe (LGT) TWY edge LGT, Taxiing guidance sign TWY:SOUTH TWY (LGT) TWY CL LGT
3	Stop bars	Nil
4	Remarks	(Marking) Overrun area (LGT) Apron flood LGT

RJBD / NANKI-SHIRAHAMA

180° turn on RWY

RWY Turn Pads are installed as shown in below figure, and procedures for 180° turn on RWY is established for RWY 15 and 33 as follows :

- a: Proceed along the RWY Center Line to the starting point of the RWY Turn Pad Center Line Marking ; then
- b: Proceed along the RWY Turn Pad Center Line Marking to see the Turning Point Indicator Light 1 on a straight line, then commence turn at the spot where you (pilot) can see Turning Point Indicator Light 2 on a straight line at angle of 9 o'clock. When turning, take MAX STEERING ANGLE.

NANKI-SHIRAHAMA AP

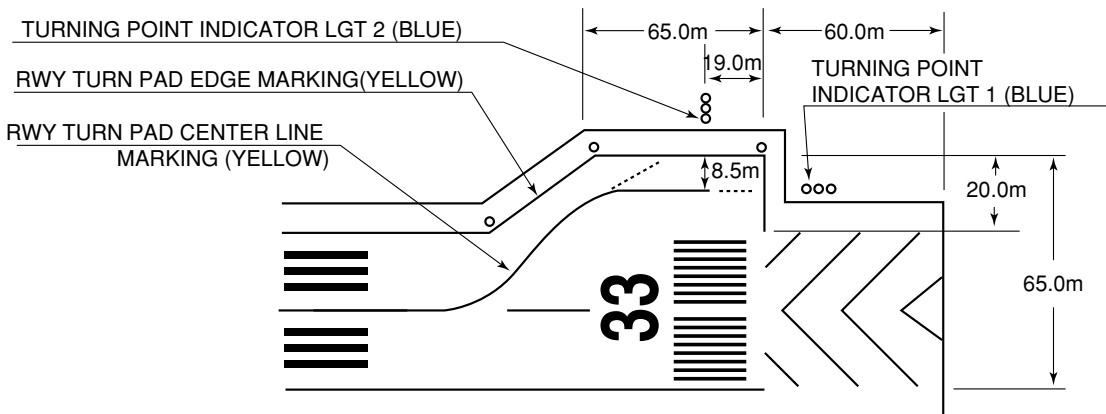
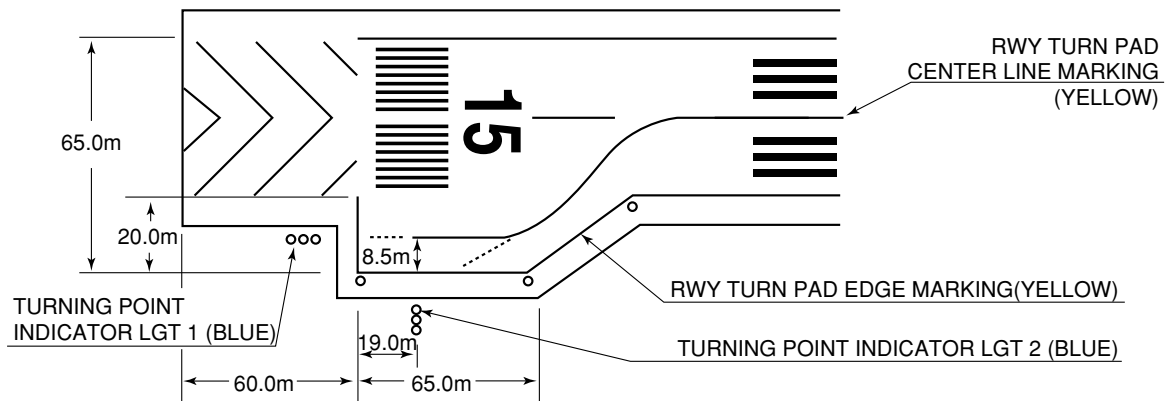

RJBD AD 2.10 AERODROME OBSTACLES

In approach/TKOF areas

RWY/Area affected	Obstacle type	Coordinates	Elevation	Markings/ LGT	Remarks
Nil					

In circling area and at AD

Obstacle type	Coordinates	Elevation	Markings/ LGT	Remarks
Mountain forest	334008N 1352242E	511ft	- / LIM(Red)	Above horizontal surface
Mountain forest	334005N 1352201E	535ft	- / LIM(Red)	Above horizontal surface

RJBD AD 2.11 METEOROLOGICAL INFORMATION PROVIDED

1	Associated MET Office	KANSAI
2	Hours of service MET Office outside hours	H24 (KANSAI)
3	Office responsible for TAF preparation Periods of validity	Nil
4	Trend forecast Interval of issuance	Nil
5	Briefing/ consultation provided	Briefing is available upon inquiry at KANSAI
6	Flight documentation Language(s) used	C En
7	Charts and other information available for briefing or consultation	S ₆ , U ₈₅ , U ₇ , U ₅ , U ₃ , U ₂₅ , U ₂ /T _r , P _S , P ₅ , P ₃ , P ₂₅ , P _{SWE} , P _{SWF} , P _{SWG} , P _{SWI} , P _{SWM} , P _{SW} (domestic), E, C, W _E , W _F , W _G , W _I , W, N
8	Supplementary equipment available for providing information	Nil
9	ATS units provided with information	RADIO
10	Additional information (limitation of service, etc.)	Nil

RJBD AD 2.12 RUNWAY PHYSICAL CHARACTERISTICS

Designations RWY NR	TRUE BRG	Dimensions of RWY(M)	Strength(PCN) and surface of RWY	THR coordinates THR geoid undulation	THR elevation and highest elevation of TDZ of precision APP RWY
1	2	3	4	5	6
15	140.97°	2000×45	PCN 45/F/B/X/T Asphalt Concrete	334009.54N 1352127.85E 124ft	THR ELEV: 298ft
33	320.97°	2000×45	PCN 45/F/B/X/T Asphalt Concrete	333919.11N 1352216.74E 124ft	THR ELEV: 274ft
Slope of RWY		Strip Dimensions(M)	RESA (Overrun) Dimensions(M)	Remarks	
7		10	11	14	
See AD Chart		2120×150	40×150	RWY Grooving 2000×30m	
See AD Chart		2120×150	40×150	RWY Grooving 2000×30m	

RJBD AD 2.13 DECLARED DISTANCES

RWY Designator	TORA (m)	TODA (m)	ASDA (m)	LDA (m)	Remarks
1	2	3	4	5	6
15	2000	2000	2000	2000	Nil
33	2000	2000	2000	2000	Nil

RJBD AD 2.14 APPROACH AND RUNWAY LIGHTING

RWY Designator	APCH LGT type LEN INTST	RTHL Color WBAR	PAPI (VASIS) Angle DIST FM THR MEHT	RTZL LEN	RCLL LEN Spacing Color INTST	REDL LEN Spacing Color INTST	RENL Color WBAR	STWL LEN Color
1	2	3	4	5	6	7	8	9
15	SALS (*1) 420 LIH	Green	PAPI 3.0°/LEFT 385.4m 61ft	Nil	2000m 30m Coded color (Whitel/Red) LIH	2000m 60m Coded color (Whitel/Yellow) LIH	Red	Nil (*2)
33	Nil	Green	PAPI 3.0°/LEFT 336.8m 61ft	Nil	2000m 30m Coded color (Whitel/Red) LIH	2000m 60m Coded color (Whitel/Yellow) LIH	Red	Nil (*2)
Remarks								
10								
SALS with RAI(LEN:360m)(*1) Overrun area edge LGT(LEN: 60m Color: Red)(*2) CGL for RWY 33 RWY THR ID LGT for RWY 33 THR (Color: White)								

RJBD AD 2.15 OTHER LIGHTING, SECONDARY POWER SUPPLY

1	ABN/IBN location, characteristics and hours of operation	ABN: 333939N/1352142E, White/Green EV4.3sec, HO
2	LDI location and LGT Anemometer location and LGT	Anemometer : RWY 15 : 250m from RWY 15 THR, LGTD RWY 33 : 300m from RWY 33 THR, LGTD
3	TWY edge and centerline lighting	TWY edge LGT: Blue TWY CL LGT: South TWY only, ALTN Green/Yellow FM RWY leaving report point, other Green
4	Secondary power supply/ switch-over time	Within 15 sec: SALS, PAPI, REDL, RTHL, CGL, RAI, REDL, RWY THR ID LGT, RCLL, Overrun area edge LGT, TWY edge LGT, TWY CL LGT, Taxing guidance sign, Turning point indicator LGT, WDI LGT, ABN, Apron flood LGT
5	Remarks	WDI LGT

RJBD AD 2.16 HELICOPTER LANDING AREA

Nil

RJBD AD 2.17 ATS AIRSPACE

Designation and lateral limits		Vertical limits (ft)	Airspace classification	ATS unit call sign Language	Remarks
1		2	3	4	6
Nankishirahama Information zone	Area within a radius of 9km(5NM) of ARP	3,000 or below	E	NANKI SHIRAHAMA RADIO En	

RJBD AD 2.18 ATS COMMUNICATION FACILITIES

Service designation	Call sign	Frequency	Hours of operation	Remarks
1	2	3	4	5
A/G	Nanki Radio	118.55MHz(1) 126.2MHz	2330 - 1100	(1)Primary

RJBD AD 2.19 RADIO NAVIGATION AND LANDING AIDS

Type of aid (VOR declination)	ID	Frequency	Hours of operation	Position of transmitting antenna coordinates	Elevation of DME transmitting antenna	Remarks
1	2	3	4	5	6	7
VOR (7°W/2012)	NKE	109.05MHz	H24	333940.55N/ 1352133.89E		
DME	NKE	1114MHz (CH-27Y)	H24	333940.55N/ 1352133.89E	338ft	
LOC 15	INK	108.55MHz	2330 - 1100	333919.24N/ 1352221.36E		LOC: 80m(262ft) away FM RWY 33 THR, 105m(344ft) E of RCL, BRG(MAG)146° LOC off set angle 1.6°
LOC-DME 15	INK	1109 MHz (CH-22Y)	2330 - 1100	333919.54N/ 1352223.22E	285ft	DME: 95m(312ft)away FM RWY 33 THR, 139m (456ft) E of RCL.
MSAS		1575.42MHz	H24			Transmitting antennas are satellite based

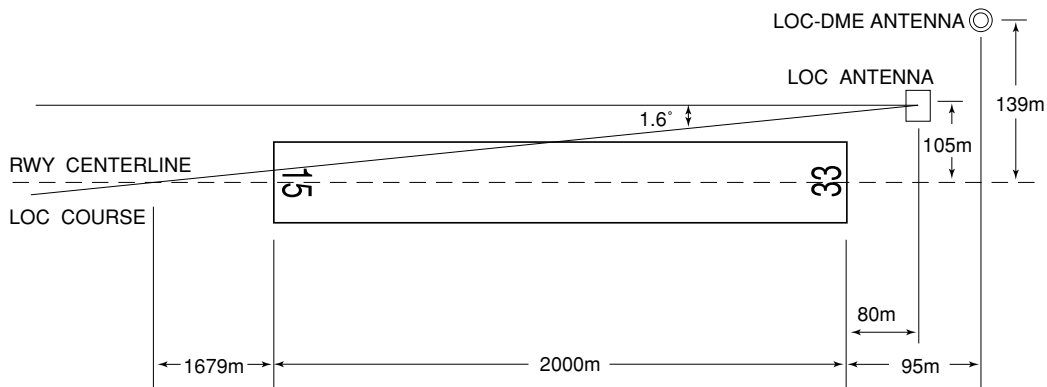

REMARKS : 1. LOC OFF SET ANGLE 1.6°
 2. LOC beam BRG(MAG) 146°
 3. ELEV of LOC-DME 86.6m(285ft)

RJBD AD 2.20 LOCAL TRAFFIC REGULATIONS

1. Airport regulations

■ For the use of this AP:PPR (tel 0739-43-0095)

2. Taxiing to and from stands

Nil

3. Parking area for small aircraft(General aviation)

Nil

4. Parking area for helicopters

Nil

5. Apron - taxiing during winter conditions

Nil

6. Taxiing - limitations

Nil

7. School and training flights - technical test flights - use of runways

Nil

8. Helicopter traffic - limitation

Nil

9. Removal of disabled aircraft from runways

Nil

RJBD AD 2.21 NOISE ABATEMENT PROCEDURES

Nil

RJBD AD 2.22 FLIGHT PROCEDURES

TAKE OFF MINIMA

	RWY	ACFT CAT	REDL & RCLL		REDL or RCLL or RCL Marking		NIL (DAYTIME ONLY)	
			CEIL-RVR	CEIL-VIS	CEIL-RVR	CEIL-VIS	CEIL-RVR	CEIL-VIS
Multi-Engine ACFT with TKOF ALTN AP FILED	15	A,B,C,D	-	0'-400m	-	0'-400m	-	0'-500m
	33	A,B,C,D	-	200'-2400m	-	200'-2400m	-	200'-2400m
OTHER	15	A,B,C,D	AVBL LDG MINIMA					
	33	A,B,C,D						

RJBD AD 2.23 ADDITIONAL INFORMATION

Nil

RJBD AD 2.24 CHARTS RELATED TO AN AERODROME

Aerodrome/Heliport Chart
 Standard Departure Chart - Instrument (NANKI)
 Standard Departure Chart - Instrument (KUSHIMOTO-RNAV)
 Standard Arrival Chart - Instrument (RAYJO-RNAV)
 Instrument Approach Chart (LOC RWY15)
 Instrument Approach Chart (VOR RWY15)
 Instrument Approach Chart (VOR A)
 Instrument Approach Chart (RNAV(GNSS) RWY15)
 Instrument Approach Chart (RNAV(GNSS) RWY33)
 Other Chart (Visual REP)
 Other Chart (LDG CHART)
 Other Chart (MVA CHART)

RJBD / NANKI-SHIRAHAMA

AD CHART

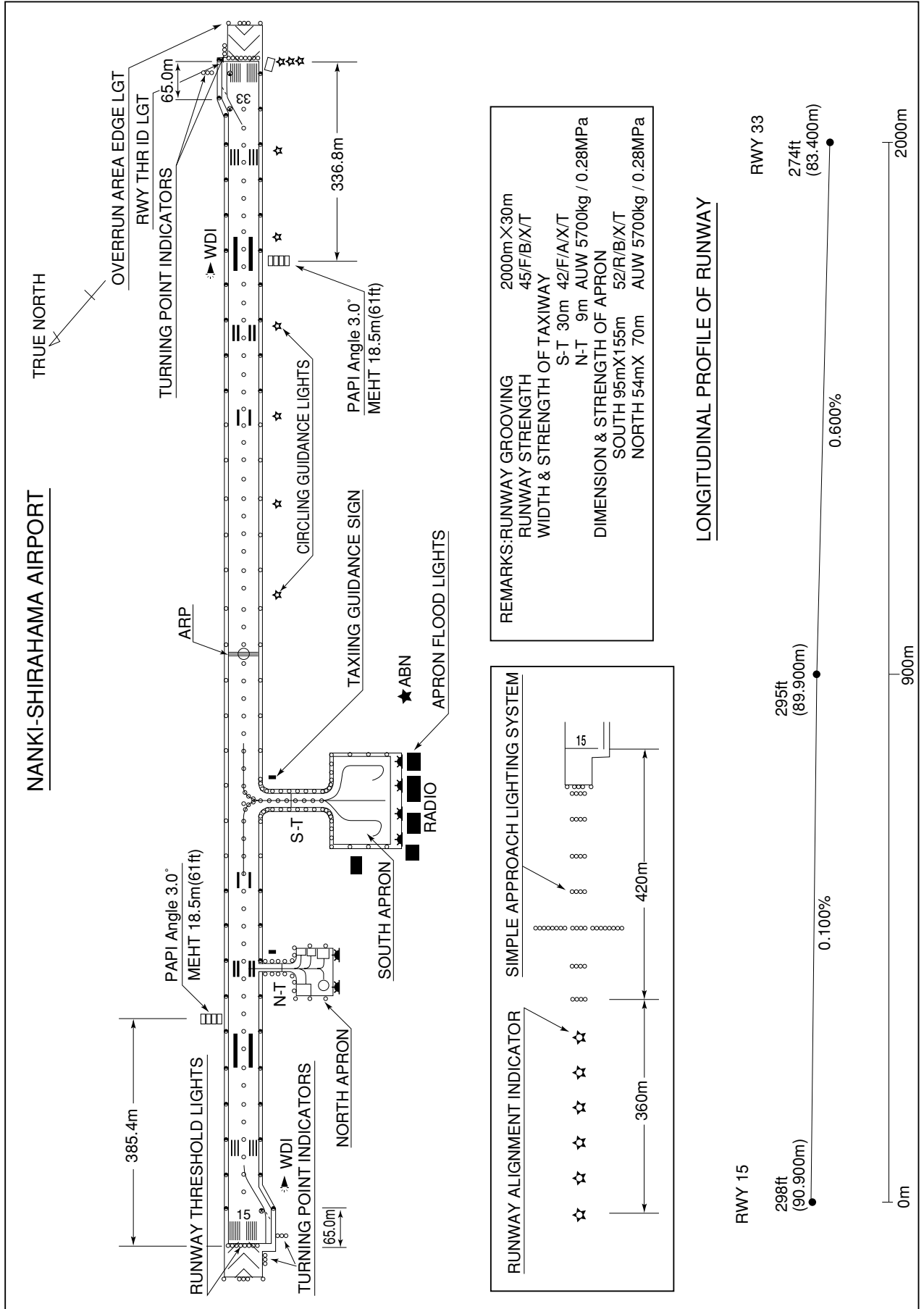

INTENTIONALLY LEFT BLANK

STANDARD ARRIVAL CHART - INSTRUMENT

RJBD / NANKI-SHIRAHAMA

RNAV STAR

RAYJO NORTH ARRIVAL / RAYJO SOUTH ARRIVAL	Basic RNP1
---	------------

Note GNSS required.

VAR 7° W(2017)

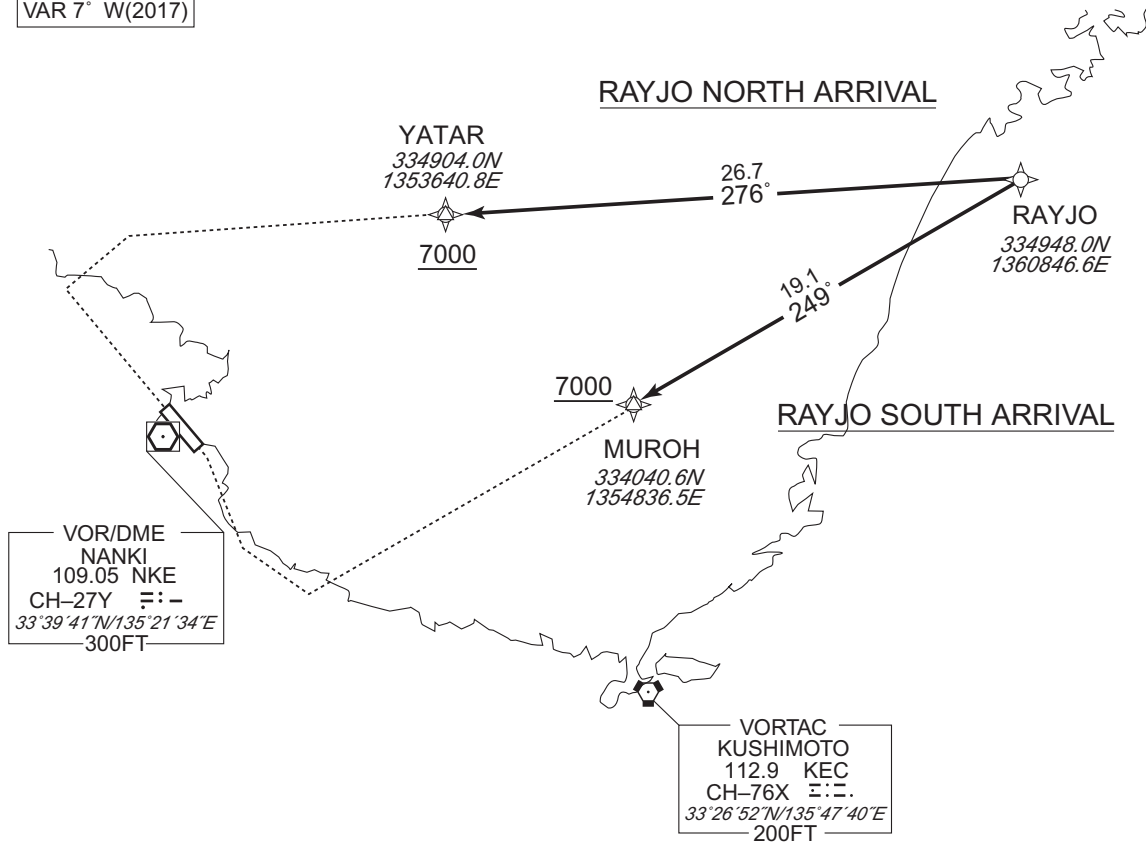

RAYJO NORTH ARRIVAL

From RAYJO, to YATAR at or above 7000FT.

Serial Number	Path Descriptor	Waypoint Identifier	Fly Over	Course °M(°T)	Magnetic Variation	Distance (NM)	Turn Direction	Altitude (FT)	Speed (KIAS)	Vertical Angle	Navigation Specification
001	IF	RAYJO	-	-	-7.3	-	-	-	-	-	Basic RNP1
002	TF	YATAR	-	276 (268.6)	-7.3	26.7	-	+7000	-	-	Basic RNP1

RAYJO SOUTH ARRIVAL

From RAYJO, to MUROH at or above 7000FT.

Serial Number	Path Descriptor	Waypoint Identifier	Fly Over	Course °M(°T)	Magnetic Variation	Distance (NM)	Turn Direction	Altitude (FT)	Speed (KIAS)	Vertical Angle	Navigation Specification
001	IF	RAYJO	-	-	-7.3	-	-	-	-	-	Basic RNP1
002	TF	MUROH	-	249 (241.5)	-7.3	19.1	-	+7000	-	-	Basic RNP1

INTENTIONALLY LEFT BLANK

INSTRUMENT APPROACH CHART

RJBD / NANKI-SHIRAHAMA

RNAV(GNSS) RWY15

TOKYO CONTROL 133.5 – 124.95 227.6 – 315.7	1. DME/DME RNP0.3 not authorized. 2. RNP0.3 required. 3. GNSS required.	NANKI RADIO 118.55 – 126.2	NO RADAR
--	---	-------------------------------	----------

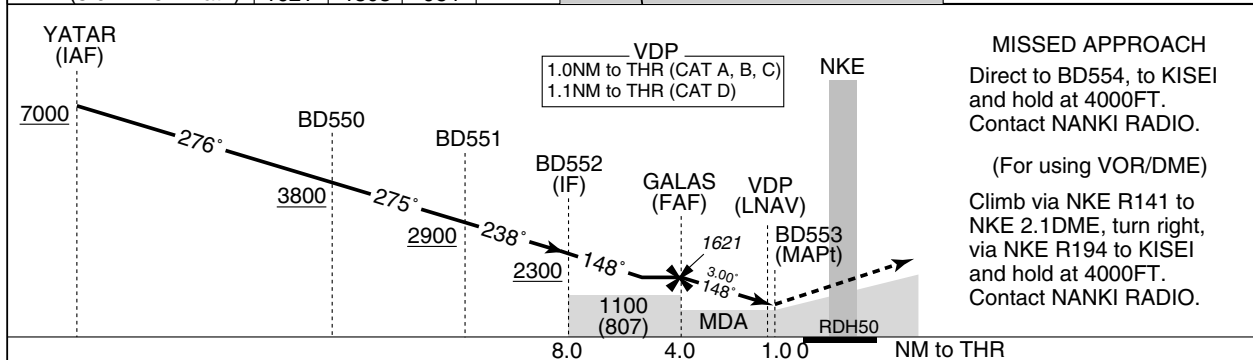
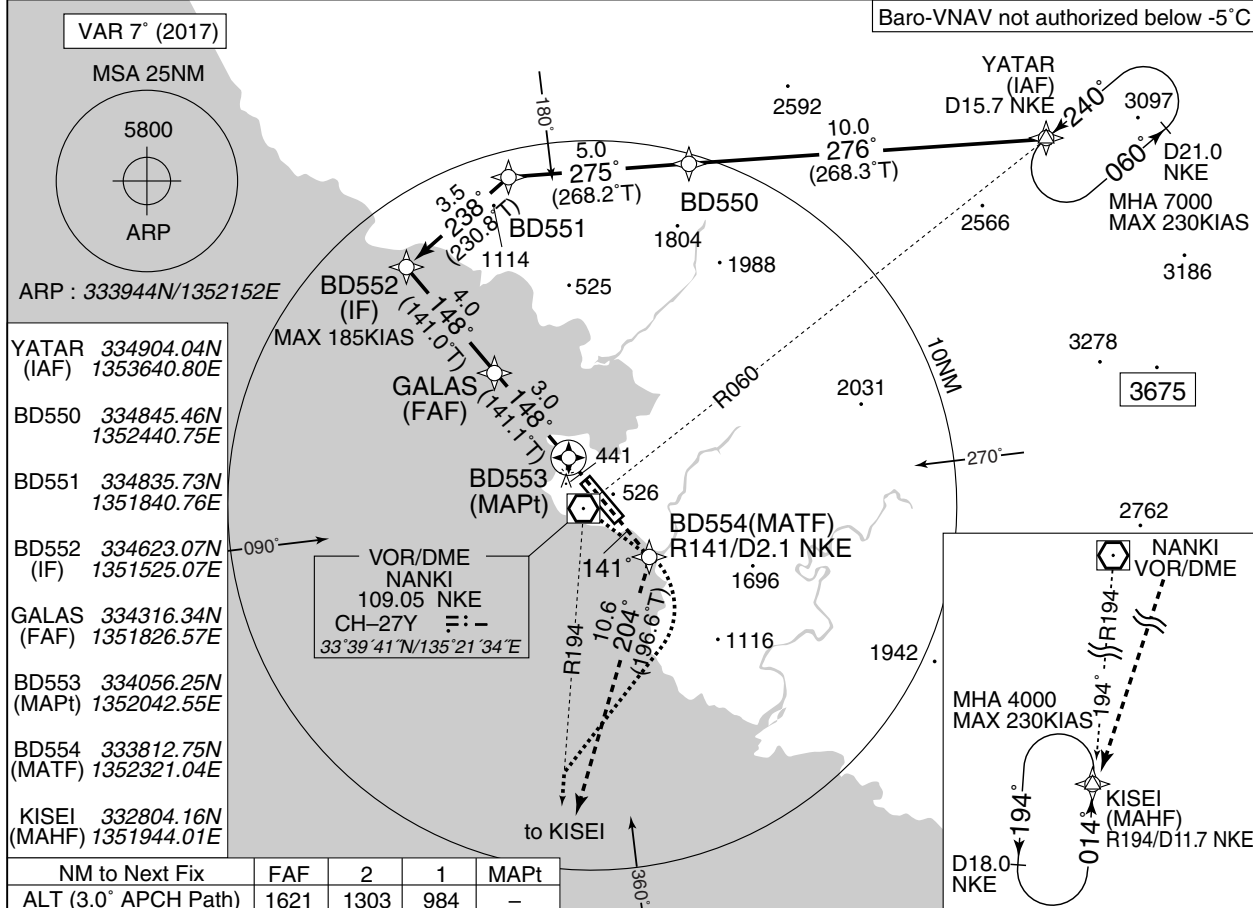

Missed APCH climb gradient MNM 5.0%

MINIMA		THR elev. 298		AD elev. 293	
CAT	LNAV/VNAV		LNAV		CIRCLING
	DA(H)	CMV	MDA(H)	CMV	MDA(H) VIS
A	700 (402)	900	660 (367)	900	1600
B		1000		1000	
C					2400
D	720 (422)	1400	690 (397)	1400	1150 (857) 3200

MINIMA with Missed APCH climb gradient of 2.5% are not established.
Circling to WEST side of RWY only.

INSTRUMENT APPROACH CHART

RJBD / NANKI-SHIRAHAMA

RNAV(GNSS) RWY33

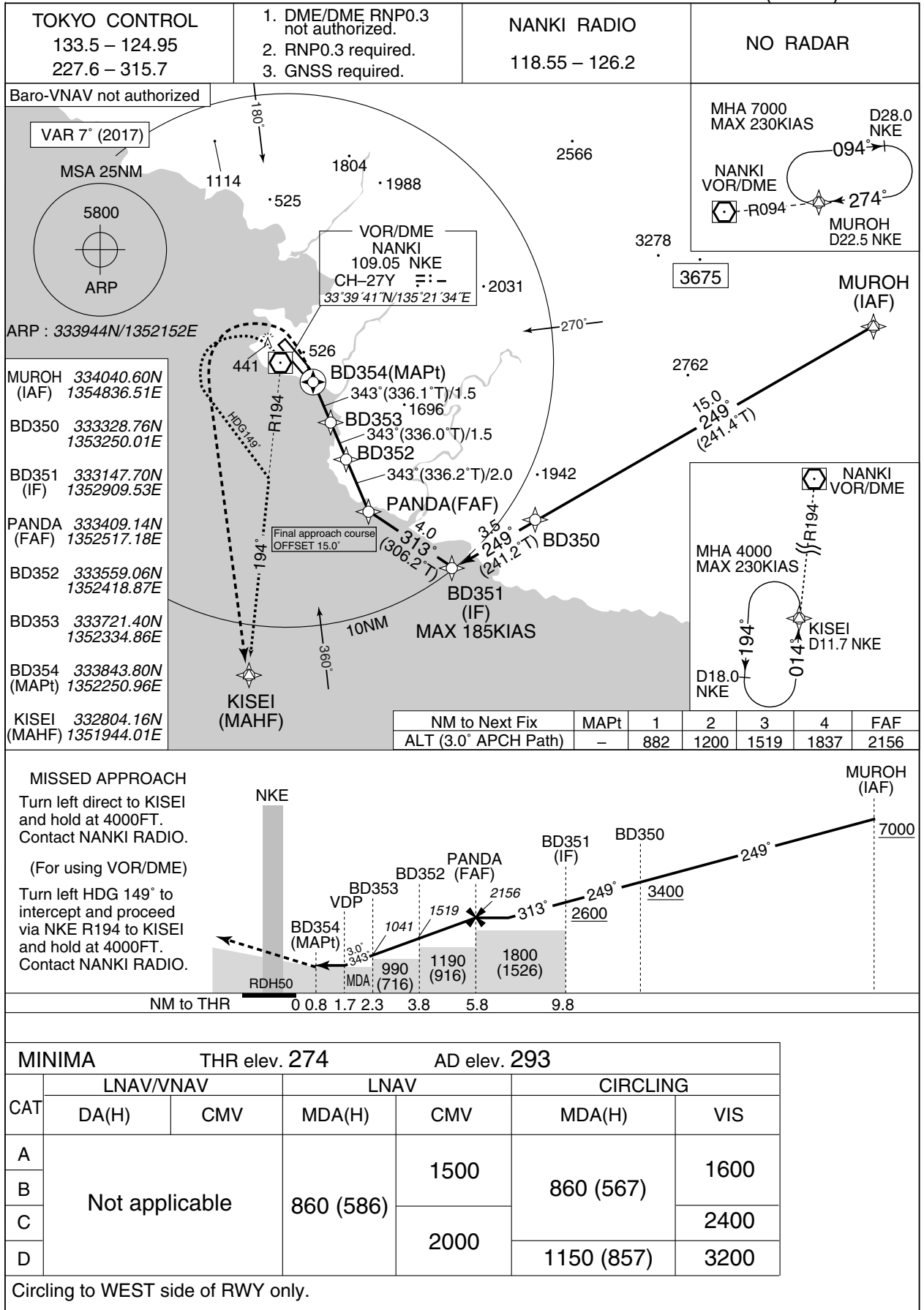

INTENTIONALLY LEFT BLANK

STANDARD DEPARTURE CHART - INSTRUMENT

RJBD / NANKI-SHIRAHAMA

SID

NANKI REVERSAL THREE DEPARTURE

RWY15 : Climb on HDG163° to NKE 4.0DME, turn right,...

RWY33 : Climb RWY HDG to 1500FT, turn left,....

...direct to NKE VOR/DME.

Cross NKE VOR/DME at or above 4000FT.

Note RWY15 : 5.8% climb gradient required up to 1300FT.

OBST ALT 984FT located at 3.1NM 139° FM end of RWY15.

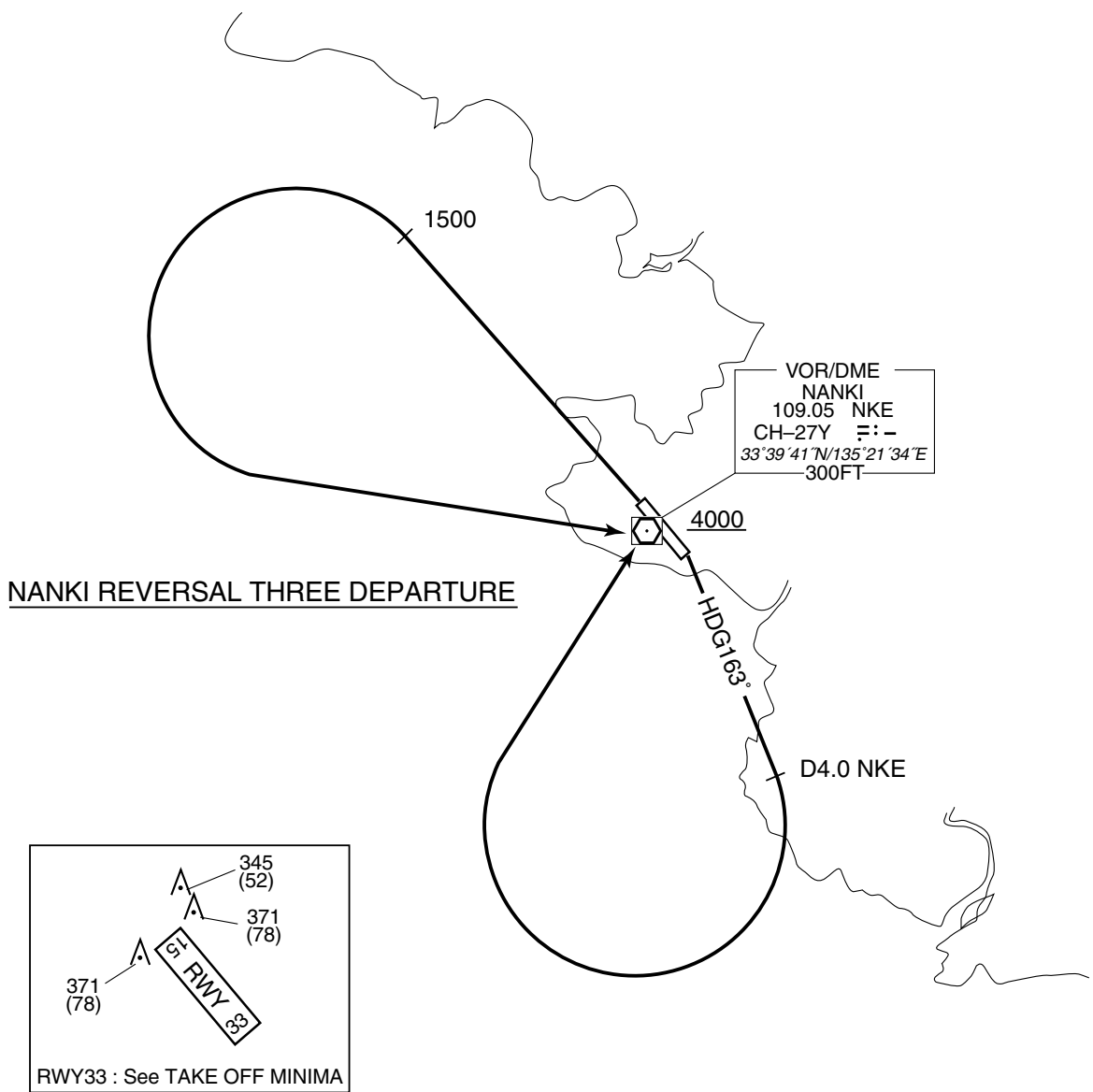

INSTRUMENT APPROACH CHART

RJBD / NANKI-SHIRAHAMA LOC RWY15

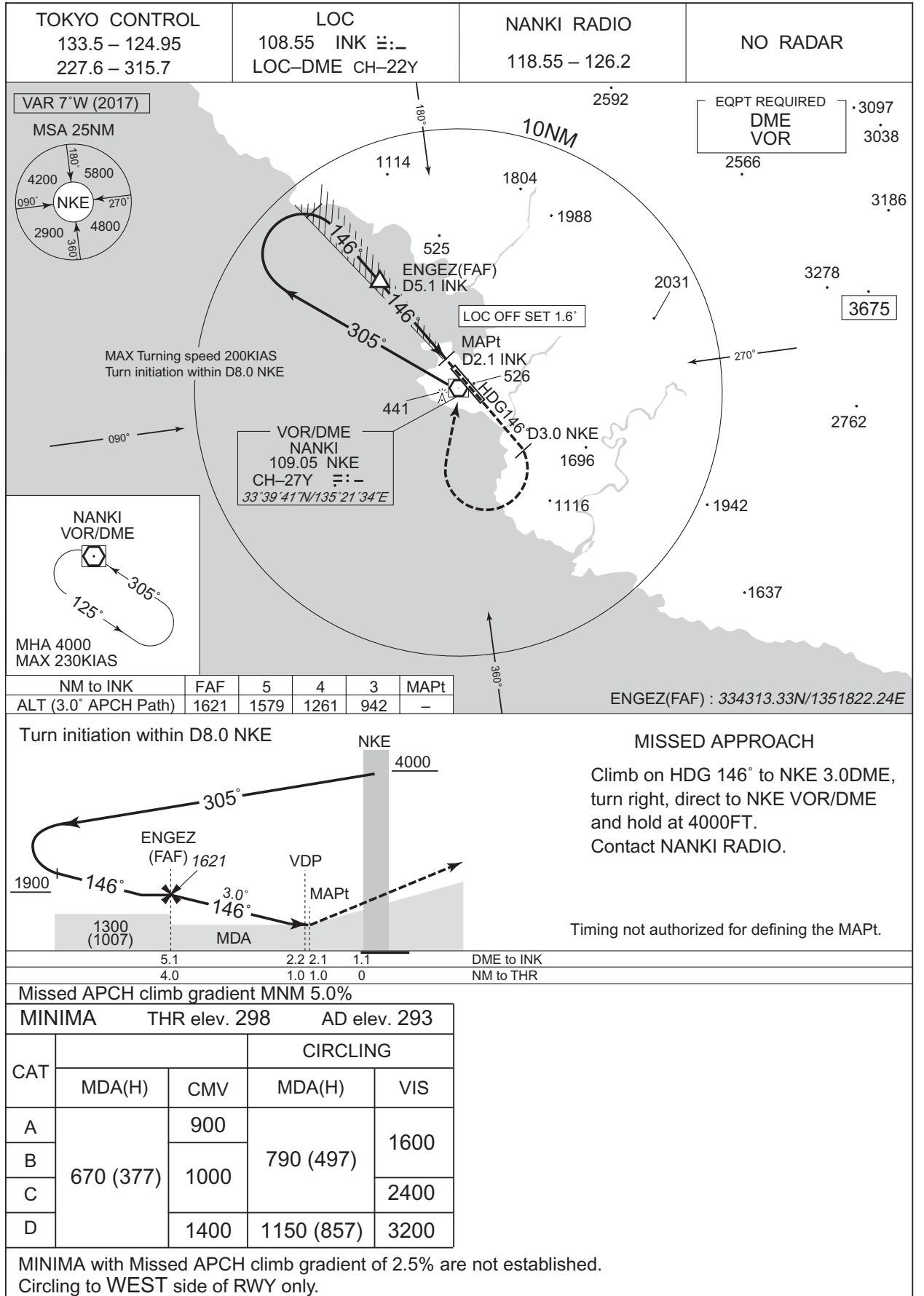

INSTRUMENT APPROACH CHART

RJBD / NANKI-SHIRAHAMA

VOR RWY15

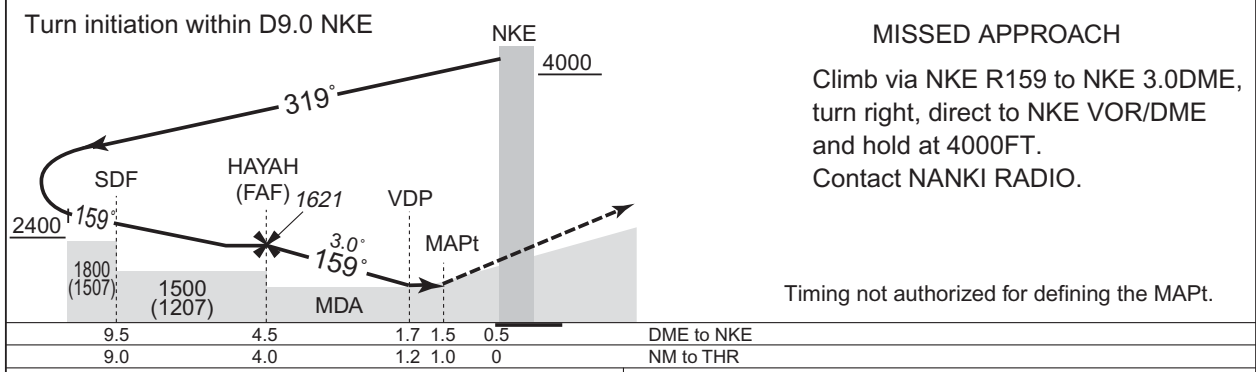
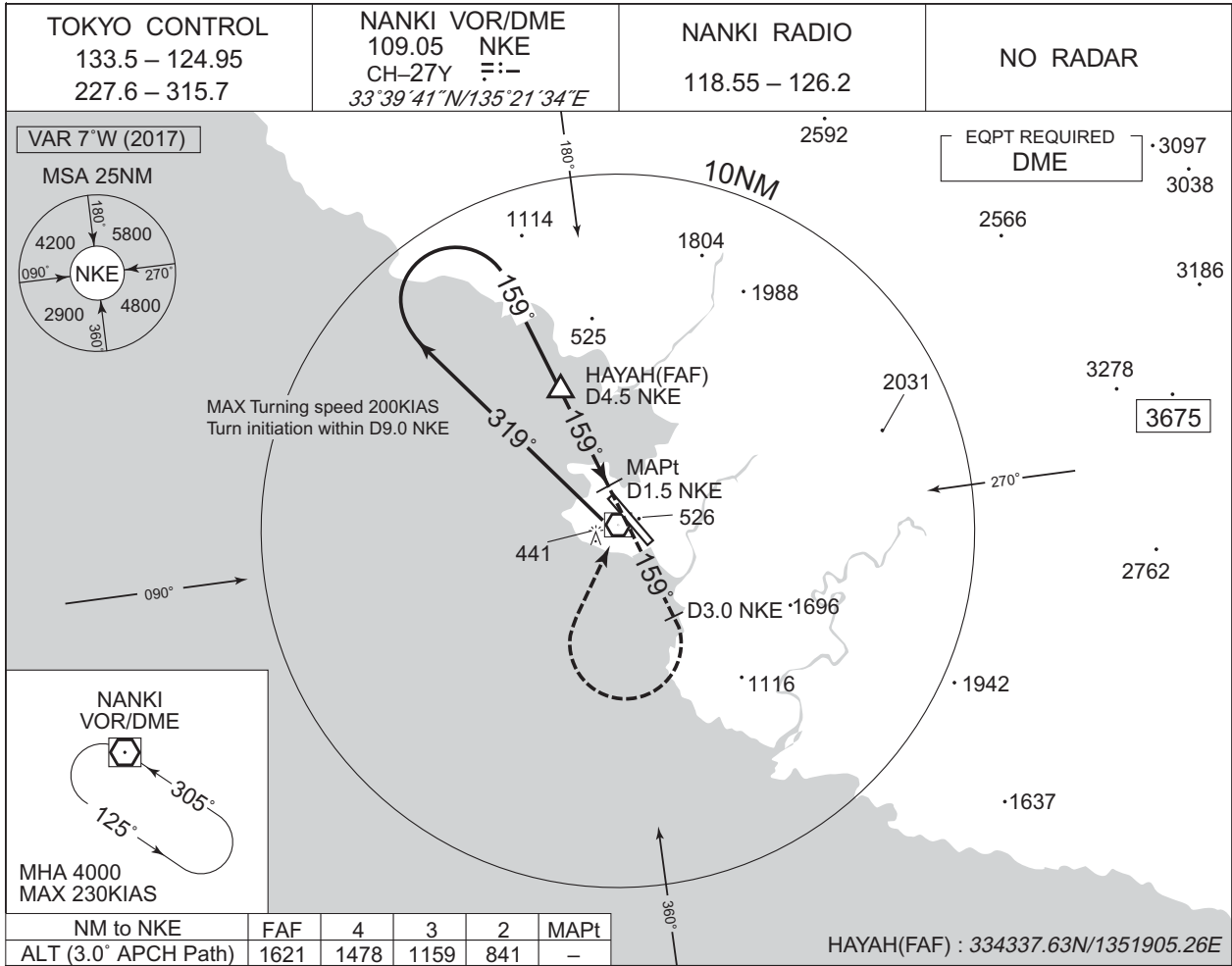

MINIMA		THR elev. 298	AD elev. 293	
CAT	CIRCLING			
	MDA(H)	CMV	MDA(H)	VIS
A	720 (427)	900	790 (497)	1600
B		1000		2400
C		1400	1150 (857)	3200
D				

Circling to WEST side of RWY only.

INSTRUMENT APPROACH CHART

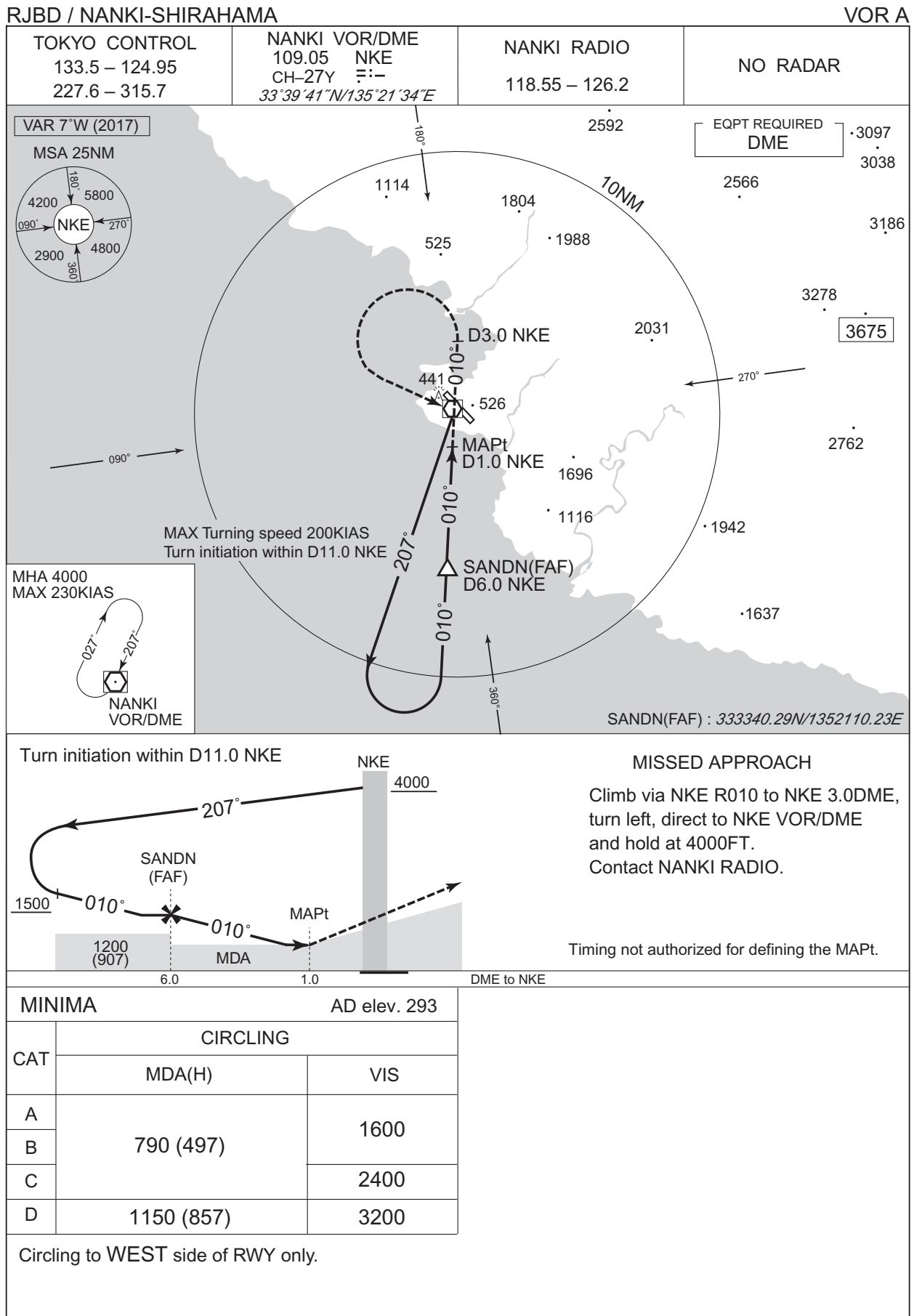

RJBD / NANKI SHIRAHAMA

Visual REP



※図中に標高を示す数字がある場合、単位はメートル(m)である。The unit of measurement used to express elevation is meter(m).

CHANGE : Map updated. BRG/DIST from ARP.

Call sign	BRG / DIST from ARP	Remarks
切目 Kirime	318°T / 9.9NM	岬 Cape
南部 Minabe	342°T / 6.6NM	JR駅 Station
生馬 Ikuma	062°T / 3.8NM	橋 Truss-bridge
合川 Gogawa	083°T / 10.0NM	ダム Dam
10NM W	270°T / 10.0NM	海上 Over the Sea
椿 Tsubaki	161°T / 3.7NM	高層ビル High Building
日置 Hiki	143°T / 7.2NM	日置川河口中洲 River-mouth

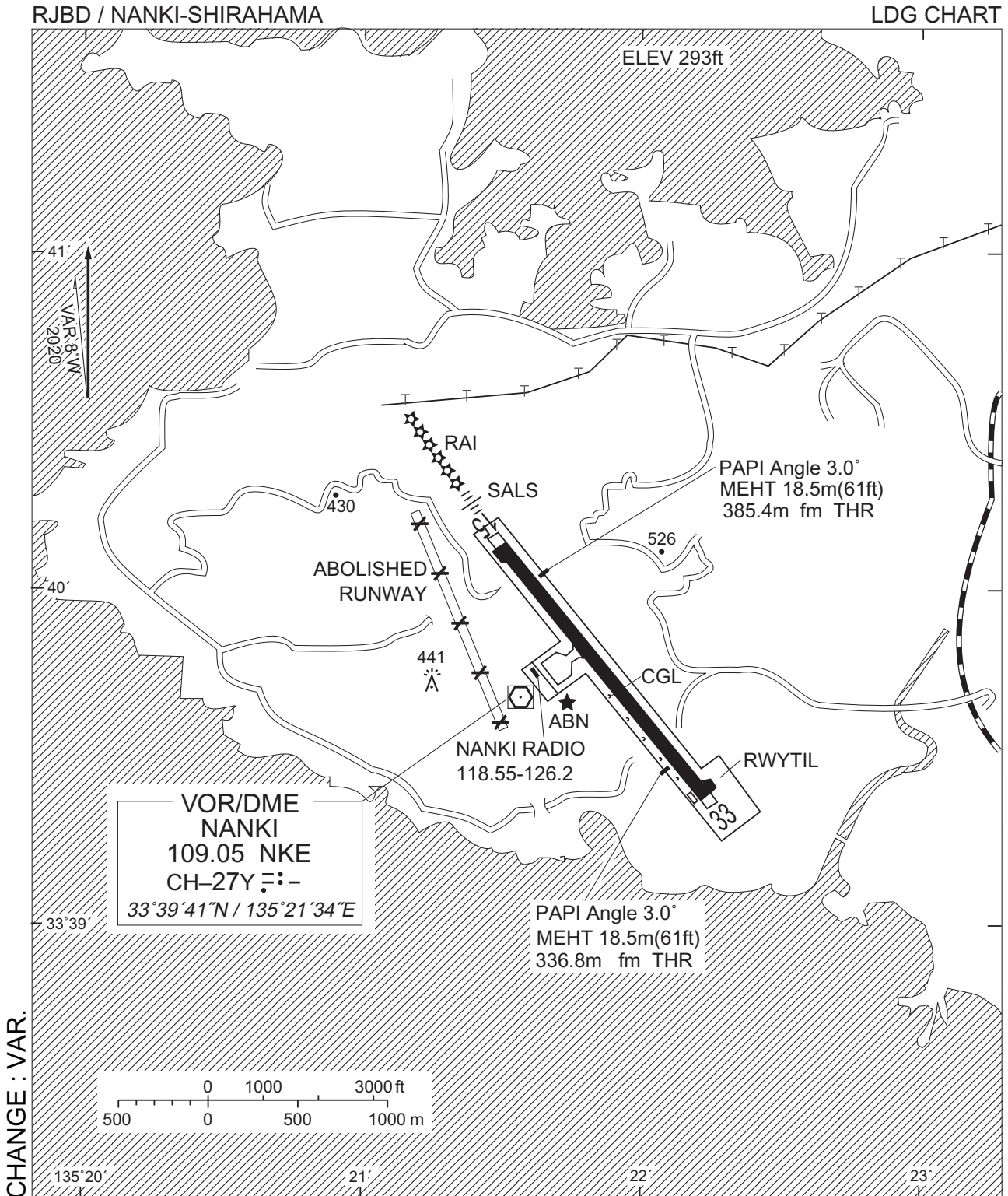

注：南紀白浜空港の西側に廃止された滑走路が(なお、禁止標識が5カ所設置されている)視認できる状態にあるので、南紀白浜空港に着陸する航空機は当該滑走路と誤認しないように注意すること。

NOTE : There is remained the abolished runway with 5 cross[×] markings at west side of Nanki-Shirahama Airport. As the abolished runway in shape is visible, the aircraft which will land on Nanki-Shirahama Airport shall pay a special attention not to confuse the runway.

RJBD / NANKI-SHIRAHAMA

Minimum Vectoring Altitude CHART

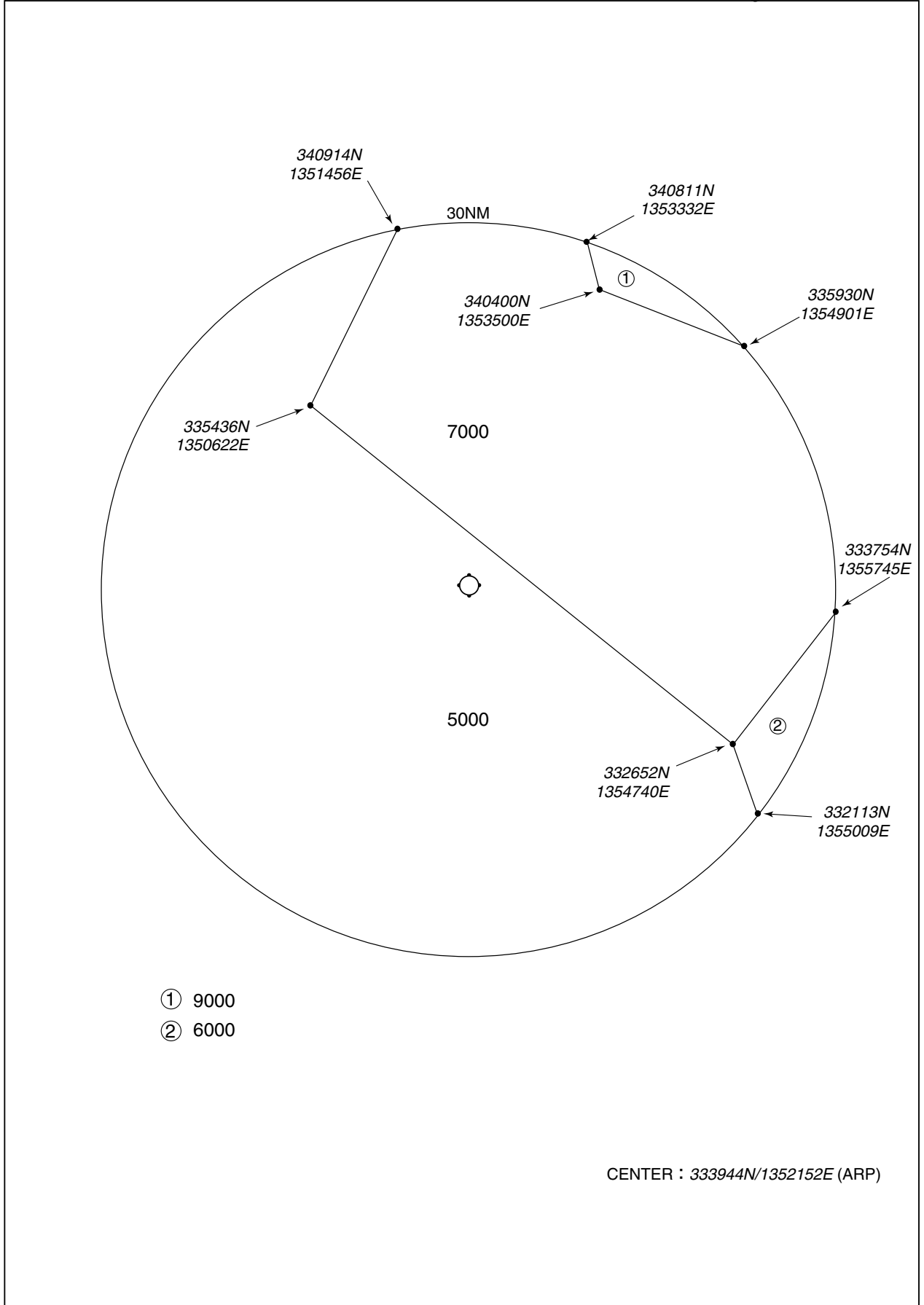

INTENTIONALLY LEFT BLANK

STANDARD DEPARTURE CHART - INSTRUMENT

RJBD / NANKI-SHIRAHAMA

RNAV SID

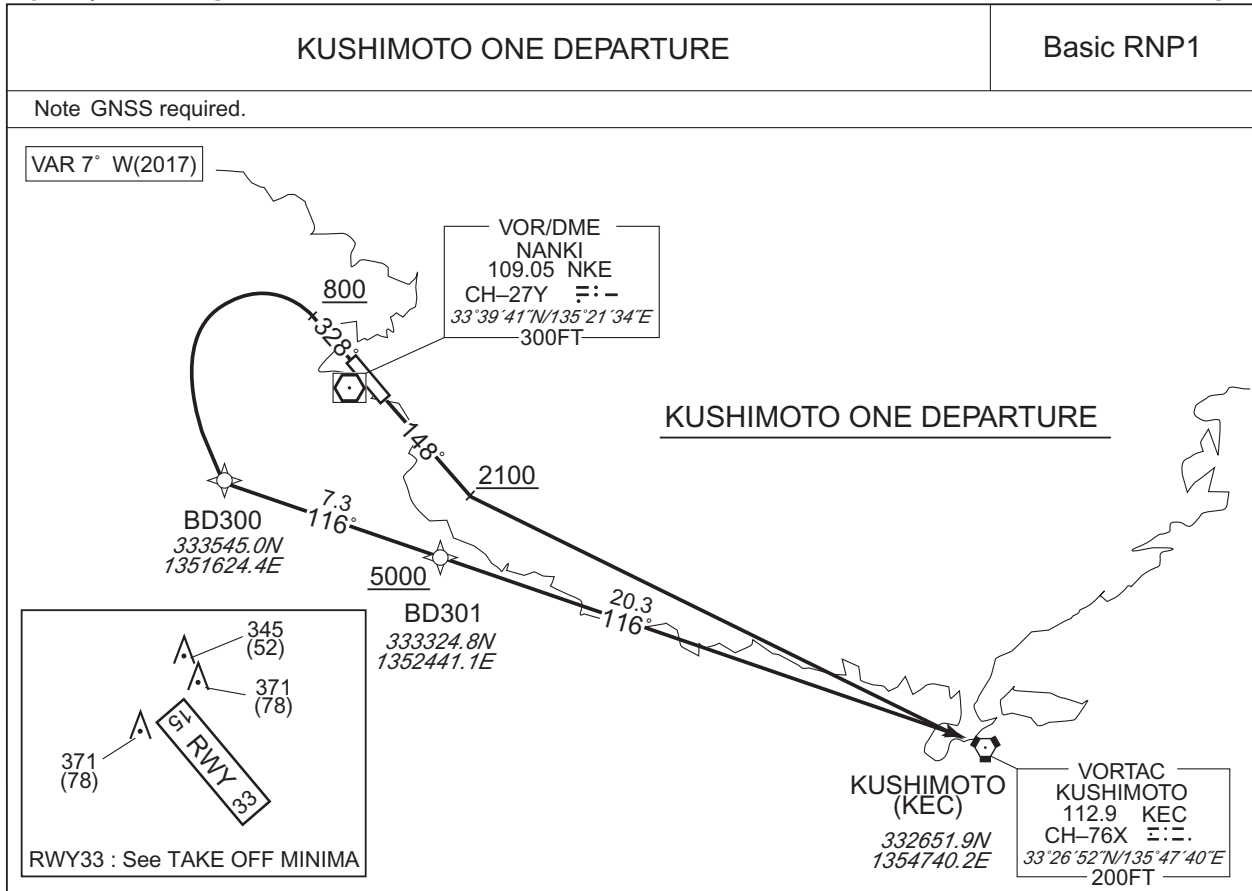

KUSHIMOTO ONE DEPARTURE

RWY15 : Climb on HDG148° at or above 2100FT, turn left direct to KEC.
 RWY33 : Climb on HDG328° at or above 800FT, turn left direct to BD300, to BD301 at or above 5000FT, to KEC.

Note RWY15 : 6.1% climb gradient required up to 2100FT.
 OBST ALT 1641FT located at 4.3NM 138° FM end of RWY15.
 OBST ALT 1903FT located at 4.2NM 119° FM end of RWY15.

RWY15

Serial Number	Path Descriptor	Waypoint Identifier	Fly Over	Course °M(°T)	Magnetic Variation	Distance (NM)	Turn Direction	Altitude (FT)	Speed (KIAS)	Vertical Angle	Navigation Specification
001	VA	-	-	148 (140.1)	-7.3	-	-	+2100	-	-	Basic RNP1
002	DF	KEC	-	-	-7.3	-	L	-	-	-	Basic RNP1

RWY33

Serial Number	Path Descriptor	Waypoint Identifier	Fly Over	Course °M(°T)	Magnetic Variation	Distance (NM)	Turn Direction	Altitude (FT)	Speed (KIAS)	Vertical Angle	Navigation Specification
001	VA	-	-	328 (321.1)	-7.3	-	-	+800	-	-	Basic RNP1
002	DF	BD300	-	-	-7.3	-	L	-	-	-	Basic RNP1
003	TF	BD301	-	116 (108.7)	-7.3	7.3	-	+5000	-	-	Basic RNP1
004	TF	KEC	-	116 (108.8)	-7.3	20.3	-	-	-	-	Basic RNP1

NANKI-SHIRAHAMA AP

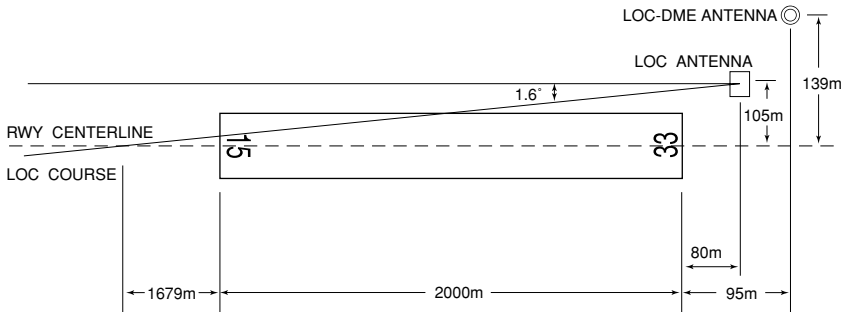

REMARKS : 1. LOC OFF SET ANGLE
2. LOC beam BRG(MAG)
3. ELEV of LOC-DME

1.6°
146°
86.6m(285ft)

RWY Turn Pads are installed as shown in below figure, and procedures for 180° turn on RWY is established for RWY 15 and 33 as follows :

- Proceed along the RWY Center Line to the starting point of the RWY Turn Pad Center Line Marking ; then
- Proceed along the RWY Turn Pad Center Line Marking to see the Turning Point Indicator Light 1 on a straight line, then commence turn at the spot where you (pilot) can see Turning Point Indicator Light 2 on a straight line at angle of 9 o'clock. When turning, take MAX STEERING ANGLE.

NANKI-SHIRAHAMA AP

